

NIT No. – C/Urban 95/2023-24/

Dated: -

REQUEST FOR PROPOSAL

For

Development of three Child and Family-friendly junctions and 1.5km Connected shared Street at Saheli Marg and Big Bazar Rd, Udaipur, Rajasthan

Bid Inviting Officer:

Commissioner Udaipur Municipal Corporation

URBAN95 Phase II, Udaipur

Address: Office of the Commissioner UMC

Udaipur Municipal Corporation,

Town Hall,

Udaipur, Rajasthan 313001,

Ph. No: +91-02942426262, E-mail: commudr@gmail.com

Website: www.udaipurmc.org



**RFP for Development of three Child and Family-friendly junctions and 1.5km
Connected shared Street at Saheli Marg and Big Bazar Rd, Udaipur, Rajasthan**

Urban95 Phase II, Udaipur

**Bid Reference No: Bidding/Tender Document for
Request for proposal for "Development of three Child and Family-friendly
junctions and 1.5km Connected shared Street at Saheli Marg and Big Bazar
Rd, Udaipur, Rajasthan**

June 2023

Estimated Project Cost ₹ 168.86 Lac

Commissioner UMC

Udaipur Municipal Corporation

(UMC) Town Hall

Udaipur-313001,

Rajasthan, India

Ph. No: 0294 42421255

Email: commudr@gmail.com

Website: <https://www.udaipurmc.org>

RFP for Development of three Child and Family-friendly junctions and 1.5km Connected shared Street at Saheli Marg and Big Bazar Rd, Udaipur, Rajasthan

DISCLAIMER

Udaipur Municipal Corporation (UMC) has prepared this Request for Proposal (RFP) for **“Development of three Child and Family-friendly junctions and 1.5km Connected shared Street at Saheli Marg and Big Bazar Rd, Udaipur, Rajasthan”**.

This RFP is a detailed document which specifies terms and conditions based on which the Bidder is expected to work. UDAIPUR MUNICIPAL CORPORATION (UMC) has taken due care in preparation of information contained herein and believes it to be accurate. However, neither UMC or any of its authorities or agencies nor any of their respective officers, employees, agents, or advisors give any warranty or make any representations, express or implied as to the completeness or accuracy of the information contained in this document or any information which may be provided in connection or arising out of it.

The information provided in this document is to assist the Bidder(s) preparing their proposals. However, this information is not intended to be exhaustive, and interested parties are expected to make their own inquiries to supplement and verify information in this document.

The information is provided on the basis that it is non-binding on UMC or any of its authorities or agencies, or any of their respective officers, employees, agents, or advisors. Each Bidder is advised to consider the RFP as per its understanding and capacity. The Bidders are also advised to do appropriate examination, enquiry and scrutiny of all aspects mentioned in the RFP before bidding. The Bidders are encouraged to take professional help of experts on financial, legal, technical, taxation, and any other matters/ sectors appearing in the document or specified work. The Bidders should go through the RFP in detail and bring to notice of UMC any kind of error, misprint, inaccuracy or omission.

UMC reserves the right not to proceed with the Project, to alter the timeline mentioned in this document, or to change the process or procedure to be applied. It also reserves the right to decline to discuss the Project further with any party submitting a proposal. No reimbursement of cost of any type will be paid to persons, entities, or consortiums submitting a proposal pursuant to this RFP.

RFP for Development of three Child and Family-friendly junctions and 1.5km Connected shared Street at Saheli Marg and Big Bazar Rd, Udaipur, Rajasthan

DEFINITIONS

In this document, the following terms shall have following respective meanings:

1. **“Acceptance of System/Solution”** means the system/solution shall be deemed to have been accepted by UMC, subsequent to its installation, rollout and deployment of trained manpower, when all the activities as defined in Scope of Work have been successfully executed and completed to the satisfaction of UMC/End Customer.
 2. **“Agreement”** means the Service Level Agreement to be signed between the successful bidder and UMC including all attachments, appendices, all documents incorporated by reference thereto together with any subsequent modifications, the RFP, the bid offer, the acceptance and all related correspondences, clarifications, presentations.
 3. **“Applicable Law(s)”** means any statute, law, ordinance, notification, rule, regulation, judgment, order, decree, bye-law, approval, directive, guideline, policy, requirement or other governmental restriction or any similar form of decision applicable to the relevant party and as may be in effect on the date of the execution of this Agreement and during the subsistence thereof, applicable to the Project.
 4. **“Authorized Representative/ Agency”** shall mean any person/ agency authorized by either of the parties.
 5. **“Bidder”** The word Bidder when used in the pre-award period shall be synonymous with Bidder, and when used after award of the Contract shall mean the successful Bidder with whom UMC signs the contract agreement and Service Level Agreement for executing the project.
 6. **“BDS”** shall stand for Bid Data Sheet.
 7. **“UMC”** shall stand for Udaipur Municipal Corporation.
 8. **“Confidential Information”** means the information disclosed or submitted to the service provider by the UMC in written, representational, electronic, verbal or other forms and includes all data, materials, products, technology, computer programs, specifications, manuals, business plans, software, marketing plans, financial information, human resource information and any other information disclosed or submitted whether prior to or after the date of this RFP, including without limitation, the information on the contents and existence of this RFP and analysis, compilations, studies and other documents prepared by either Party which contain or otherwise reflect or are generated from any Confidential Information.
 9. **“Contract”** is used synonymously with Agreement.
 10. **“Corrupt Practice”** means the offering, giving, receiving, or soliciting of anything of value or influence the action of a public official in the process of Contract execution.
 11. **“Default Notice”** means the written notice of Default of the Agreement issued by one Party to the other in terms hereof.
 12. **“Document”** means any embodiment of any text or image however recorded and includes any data, text, images, sound, voice, codes, databases or any other electronic documents as per the Information Technology Act, 2000.
 13. **“Effective Date”** means the date of Release of Purchase Order.
 14. **“Fraudulent Practice”** means a misrepresentation of facts in order to influence a procurement process or the execution of a Contract and includes collusive practice
-

RFP for Development of three Child and Family-friendly junctions and 1.5km Connected shared Street at Saheli Marg and Big Bazar Rd, Udaipur, Rajasthan

among Bidders (prior to or after Bid submission) designed to establish Bid prices at artificial non- competitive levels and to deprive UMC of the benefits of free and open competition.

15. **“Good Industry Practice”** means the exercise of that degree of skill, diligence and prudence which would reasonably and ordinarily be expected from a reasonably skilled and experienced Operator engaged in the same type of undertaking under the same or similar circumstances.
 16. **“GOI”** shall stand for Government of India.
 17. **“IFB”** shall stand for Invitation for Bids.
 18. **“ITB”** shall stand for Instructions to Bidders.
 19. **“Implementation Period”** shall mean the period from the date of signing of the Agreement and up to the issuance of Final Acceptance Certificate.
 20. **“Intellectual Property Rights”** means any patent, copyright, trademark, trade name, service marks, brands, proprietary information whether arising before or after the execution of this RFP and the right to ownership and registration of these rights.
 21. **“JV”** shall stand for Joint Venture.
 22. **“Law”** shall mean any act, notification, by- law, rules and regulations, directive, ordinance, order or instruction having the force of law enacted or issued by the Central Government and/ or the State Government or any other Government or regulatory authority or political subdivision of government agency.
 23. **“LoI”** means Letter of Intent, which constitutes the intention of the UMC to place the Purchase Order with the successful bidder.
 24. **“NIT”** shall stand for Notice Inviting Tender.
 25. **“Operator”** means the entity/company providing the services / executing the project under the Agreement and is used synonymous with Bidder/Successful Bidder.
 26. **“Request for Proposal”**, means the detailed notification seeking a set of solution(s), services(s), materials and/or any combination of them.
 27. **“Requirements”** shall mean and include schedules, details, description, statement of technical data, performance characteristics, standards (Indian as well as International) as applicable and specified in the Agreement.
 28. **“Site”** means the location(s) for which the Contract will be signed and where the service shall be provided as per the agreement.
 29. **“Service”** means provision of Contracted service viz., operation, maintenance, and associated services for UMC.
 30. **“Third Party Agency”** means any agency, if/as appointed by UMC for monitoring the UMC Project during commissioning and operation.
 31. **“Termination Notice”** means the written notice of termination of the Agreement issued by one Party to the other in terms hereof.
 32. **“Work Order”** shall mean a formal order issued by UMC to the successful bidder covering delivery timelines and other terms and conditions.
-

RFP for Development of three Child and Family-friendly junctions and 1.5km Connected shared Street at Saheli Marg and Big Bazar Rd, Udaipur, Rajasthan

List of Abbreviations

| S/n | Abbreviation | Definition |
|-----|-------------------|--|
| 1. | AMRUT | Atal Mission for Rejuvenation and Urban Transformation |
| 2. | AWC | Aanganwadi Centre |
| 3. | BSR | Basic Schedule of Rates BSR |
| 4. | BvLF | Bernard van Leer Foundation |
| 5. | CDP | City Development Plan |
| 6. | CFFTJ | Child and Family Friendly Traffic Junctions |
| 7. | CFSC | Child- Friendly Smart Cities |
| 8. | CPZ | Child Priority Zone |
| 9. | CSCAF | Climate Smart Cities Assessment Framework |
| 10. | CSR | Corporate Social Responsibility |
| 11. | DPR | Detailed Project Report |
| 12. | ECD | Early Childhood Development |
| 13. | EU | European Union |
| 14. | EWS | Economic Weaker Section |
| 15. | FGD | Focused Group Discussions |
| 16. | GHG | Greenhouse Gas |
| 17. | GoI | Government of India |
| 18. | HIG | High Income Group |
| 19. | ICLEI- South Asia | ICLEI – Local Governments for Sustainability, South Asia |
| 20. | IPT | Intermediate Public Transport |
| 21. | ITC | Infant, Toddler and Caregiver |
| 22. | ITC | Infant, Toddler, and Care- giver |
| 23. | ITCN | Infant, Toddler and Caregiver Friendly Neighbourhood |
| 24. | ITDP | Institute for Transportation and Development Policy |
| 25. | KII | Key Informant Interviews |
| 26. | LCMP | Low Carbon Mobility Plan |
| 27. | LIG | Lower Income Group |
| 28. | MIG | Middle Income Group |
| 29. | MoHUA | Ministry of Housing and Urban Affairs |
| 30. | NCAP | National Clean Air Program |
| 31. | NIUA | National Institute of Urban Affairs |
| 32. | O&M | Operational & Maintenance |
| 33. | PHC | Primary Healthcare Centre |
| 34. | PHED | Public Health Engineering Department |
| 35. | PMSU | Project Management Steering Unit |
| 36. | PMU | Project Management Unit |
| 37. | PMU | Project Management Unit |
| 38. | PT | Public Transport |
| 39. | PWD | Public Works Department |
| 40. | RBA | Rapid Behavioural Assessment |
| 41. | RTDC | Rajasthan Tourism Development Corporation |
| 42. | RUIDP 2022 | Rajasthan Urban Infrastructure Development Project |
| 43. | SBC | Social and Behavioural Change |
| 44. | SCM | Smart City Mission |
| 45. | SOR | Schedule of Rates |
| 46. | SP | Sensory Park |

**RFP for Development of three Child and Family-friendly junctions and 1.5km
Connected shared Street at Saheli Marg and Big Bazar Rd, Udaipur, Rajasthan**

| | | |
|-----|-----|-------------------------------|
| 47. | UIT | Urban Improvement Trust |
| 48. | UMC | Udaipur Municipal Corporation |

RFP for Development of three Child and Family-friendly junctions and 1.5km Connected shared Street at Saheli Marg and Big Bazar Rd, Udaipur, Rajasthan

Contents

| | |
|---|-----------|
| NIT No. – C/Urban 95/2023-24/ Dated: - | 1 |
| SECTION 1: - BACKGROUND..... | 13 |
| 1.1 Urban95..... | 14 |
| 1.2 Urban95 in India | 14 |
| 1.3 Urban95 in Udaipur | 14 |
| SECTION 2: -UDAIPUR..... | 15 |
| 2.1 Demographics, Udaipur | 15 |
| SECTION 3: -INVITATION FOR BIDS (IFB) | 16 |
| SECTION 4: -INSTRUCTIONS TO BIDDERS (ITB) & BID DATASHEET (BDS)..... | 18 |
| A. GENERAL..... | 18 |
| 4.1 Scope of Bid | 18 |
| 4.2 Source of Funds | 18 |
| 4.3 Eligible Bidders | 18 |
| 4.4 Qualification of the Bidder..... | 19 |
| 4.5 One Bid per Bidder | 21 |
| 4.6 Cost of Bidding | 21 |
| 4.7 Site Visit | 21 |
| B. BIDDING DOCUMENTS | 22 |
| 4.8 Content of Bidding Documents..... | 22 |
| 4.9 Clarification on Bidding Documents and Pre-Bid Meeting..... | 22 |
| 4.10 Amendment to Bidding Documents..... | 23 |
| C. PREPARATION OF BIDS | 24 |
| 4.11 Language of the Bid | 24 |
| 4.12 Documents comprising the Bid..... | 24 |
| Part Two: FINANCIAL PART 24 | |
| 4.13 Bid Price | 25 |
| 4.14 Currencies of Bid and Payment..... | 25 |
| 4.15 Bid Validity..... | 25 |
| 4.16 Bid Security/ Earnest Money Deposit (EMD) | 25 |
| 4.17 Alternative Proposals by Bidders..... | 26 |
| 4.18 Format & Signing of Bid..... | 26 |
| D. SUBMISSION OF BIDS | 28 |
| 4.19 Date for Submission of the Bids..... | 28 |
| 4.20 Timeline for Submission of Bids..... | 28 |
| 4.21 Late Bids | 28 |

RFP for Development of three Child and Family-friendly junctions and 1.5km Connected shared Street at Saheli Marg and Big Bazar Rd, Udaipur, Rajasthan

| | | |
|---|--|-----------|
| 4.22 | Modification, Resubmission and Withdrawal of Bids..... | 28 |
| E. BID OPENING AND EVALUATION | | 29 |
| 4.23 | Bid Opening | 29 |
| 4.24 | Confidentiality | 29 |
| 4.25 | Clarification of Bids..... | 29 |
| 4.26 | Examination of Bids, and Determination of Responsiveness..... | 29 |
| 4.27 | Correction of Errors | 30 |
| 4.28 | Conversion to Single Currency | 30 |
| 4.29 | Evaluations and Comparison of Responsive Bids | 30 |
| 4.30 | The extent of the Additional Performance security shall be as per the following ceiling: - | |
| 4.31 | Negotiation of Bids | 32 |
| 4.32 | Award of Contract..... | 32 |
| 4.33 | Employer's Right to Accept any Bid and to Reject any or all Bids..... | 32 |
| 4.34 | Notification of Award and Signing of Agreement. | 32 |
| 4.35 | Performance Security | 33 |
| 4.36 | Advance Payment and Security | 33 |
| 4.37 | Dispute Resolution..... | 33 |
| 4.38 | Corrupt or Fraudulent Practices..... | 33 |
| Appendix A..... | | 35 |
| SECTION 5: QUALIFICATION INFORMATION..... | | 38 |
| Information and Documents to be furnished along with the bid* | | 38 |
| 5.1 | Bid Submission Form..... | 38 |
| 5.2 | Proof of Cost of Bid Document | 38 |
| 5.3 | Minimum Eligibility Criteria/ Qualification Criteria | 38 |
| SECTION 6: CONDITIONS OF CONTRACT..... | | 43 |
| 6.1 | GENERAL | 43 |
| 6.2 | INTERPRETATION | 49 |
| 6.3 | Language and Law..... | 49 |
| 6.4 | Engineer's Duties and Authority | 49 |
| 6.5 | Communications..... | 51 |
| 6.6 | Sub-contracting | 51 |
| 6.7 | NOMINATED SUBCONTRACTORS | 54 |
| 6.8 | Other Contractors | 55 |
| 6.9 | Personnel | 55 |
| 6.10 | Risks..... | 55 |
| 6.11 | Insurance..... | 56 |

RFP for Development of three Child and Family-friendly junctions and 1.5km Connected shared Street at Saheli Marg and Big Bazar Rd, Udaipur, Rajasthan

| | | |
|---------------------------------------|--|-----------|
| 6.12 | Site Investigation Reports | 57 |
| 6.13 | Queries about the Contract Data..... | 57 |
| 6.14 | Contractor to Construct the Works..... | 57 |
| 6.15 | Completion of the Works..... | 58 |
| 6.16 | Approval by the Engineer..... | 58 |
| 6.17 | Safety..... | 58 |
| 6.18 | Discoveries | 58 |
| 6.19 | Possession of the Site..... | 59 |
| 6.20 | Access to the Site | 59 |
| 6.21 | Instructions..... | 59 |
| 6.22 | Disputes Resolution Mechanism | 59 |
| 6.23 | TIME CONTROL | 62 |
| 6.24 | QUALITY CONTROL..... | 65 |
| 6.25 | COST CONTROL..... | 67 |
| 6.26 | FINISHING THE CONTRACT..... | 75 |
| 6.27 | Particular Conditions of Contract..... | 80 |
| SECTION 7: CONTRACT DATA..... | | 87 |
| 7.1 | CONTRACT DATA..... | 87 |
| SECTION 8: SCOPE OF WORK | | 91 |
| 8.1 | Project Site..... | 91 |
| 8.2 | Site Characteristics | 92 |
| 8.3 | Project Objectives | 92 |
| 8.4 | PROJECT DESIGN ELEMENTS & COMPONENTS | 93 |
| 8.4.1 | Site cleaning | 93 |
| 8.4.2 | Integration of proposals from this DPR with the on-going works..... | 93 |
| 8.4.3 | Drain maintenance | 94 |
| 8.4.4 | Drain covering..... | 94 |
| 8.4.5 | Sidewalks and Cycle Tracks | 95 |
| 8.4.6 | Street Markings..... | 97 |
| 8.4.7 | Traffic calming elements..... | 98 |
| 8.4.8 | Installing ITC friendly furniture | 102 |
| 8.4.9 | Creating ITC friendly zones at the junctions | 102 |
| 8.4.10 | ITC friendly furniture along the shared street and the junctions..... | 103 |
| 8.4.11 | Addition and maintenance of the plantation around the anchor institute | 104 |
| 8.4.12 | Repairing and beautifying the dead boundary walls | 105 |
| 8.4.13 | Drinking water facility | 109 |
| 8.4.14 | Vending Zone at the Semi-Circular roundabout | 109 |

RFP for Development of three Child and Family-friendly junctions and 1.5km Connected shared Street at Saheli Marg and Big Bazar Rd, Udaipur, Rajasthan

| | | |
|--|--|------------|
| 8.4.15 | Other Recommendations..... | 110 |
| SECTION 9: PROJECT PROPOSAL- SPECIFICATIONS..... | | 112 |
| 9.1 | Summary of Work for Saheli Marg from Fatehpura Police Chowki Junction upto UIT Circle and Big Bazar Road upto Sukhadia Circle..... | 112 |
| 9.2 | Proposal Elements with Reference Images..... | 113 |
| 10.1 | Environmental and Social Standards During Construction Work of the Projects: | 121 |
| 10.2 | Environment Impact Assessment | 122 |
| 10.3 | Social Impact Assessment:..... | 124 |
| 10.4 | Safety Requirements: | 125 |
| 10.5 | Operation and maintenance..... | 126 |
| 10.6 | Project Timeline/ Milestones:..... | 128 |
| SECTION 11: DRAWINGS & BILL OF QUANTITIES | | 129 |
| 11.1 | DRAWINGS..... | 129 |
| 11.2 | ABSTRACT OF THE COST..... | 169 |
| 11.3 | BILL OF QUANTITIES..... | 170 |
| SECTION-12: - CONTRACT FORMS | | 185 |
| 1.1 | Appendix 1: Details of Bidder..... | 186 |
| 1.2 | Appendix: 2 Bid Submission Form | 187 |
| 1.3 | Appendix 3: Financial Bid/Price Schedule..... | 189 |
| Financial Bid Proposal Format | | 189 |
| 1.4 | Appendix 4: - Power of Attorney for signing of Bid | 191 |
| 1.5 | Appendix 5: Bid Security (Bank Guarantee) | 192 |
| 1.6 | Appendix 6: - Format for Evidence of Access to or Availability of Credit Facilities | 193 |
| 1.7 | Appendix 7: - Declaration regarding Blacklisting/Debarring..... | 194 |
| 1.8 | Appendix 8: Statement of Ethical Conduct, Fraud and Corruption..... | 195 |
| 1.9 | Appendix 9: - Financial standing of the Bidder | 196 |
| 1.10 | Appendix 10: - Constructions Works completed during last Five years..... | 197 |
| 1.11 | Appendix 11: - Experience in works of similar nature and size during last five years | 199 |
| 1.12 | Appendix 12: - Existing commitments and on-going works:..... | 199 |
| 1.13 | Appendix 13: - Indemnity Bond to be executed by the Contractor for the Removal/Disposal of Scrap/Disposal or Surplus material..... | 200 |
| 1.14 | Appendix 14: - DECLARATION FOR ACCEPTING TERMS AND CONDITIONS OF BID DOCUMENT | 202 |
| 1.15 | APPENDIX-15: Affidavit regarding correctness of Bidder's Information/ Documents/ Certificates | 203 |
| 1.16 | Appendix 16: - PERFORMANCE BANK GUARANTEE | 204 |
| 1.17 | Appendix 17: - LETTER OF AWARD | 205 |
| 1.18 | Appendix 18 - Agreement Form..... | 206 |

**RFP for Development of three Child and Family-friendly junctions and 1.5km
Connected shared Street at Saheli Marg and Big Bazar Rd, Udaipur, Rajasthan**

| | | |
|------|--|-----|
| 1.19 | Appendix 19: -Noticed to proceed with the work | 208 |
| 1.20 | Appendix 20: - Completion Certificate | 209 |

RFP for Development of three Child and Family-friendly junctions and 1.5km Connected shared Street at Saheli Marg and Big Bazar Rd, Udaipur, Rajasthan

SECTION 1: - BACKGROUND

Indian cities are urbanizing and growing at an unprecedented speed in recent decades, and the growth has been so rapid and uncontrolled, that cities infrastructure services has been outstripped to meet the physical and social needs much faster than anticipated. With increase in urbanization and population, India is witnessing robust growth in younger population, with 10% (~36 million) is constituted by children below 6 years¹ and another 32% of its population (~120 million) is constituted by children between 6 to 18 years of age².

Growing up in the cities is as complex as it is exciting, as with plenty of opportunities- access to better schools, sports facilities and health care, the urban environment is also wrought with threats- pollution, lack of independent mobility, inadequate play spaces, lack of recreational/ public spaces and break down of community support structures, that impact the overall growth and development of a child.

It is a well- known fact that issues that make urban life difficult for an infant, toddler or a grown up child also make it difficult for their care giver too- parents, grand parents, and other vulnerable section of society in general- women,

elderly and disabled people. Thus, making cities more infant, toddler, and their care giver (ITC) friendly is an objective that cuts across many overlapping problems and doesn't just benefit children. The overall focus on Early Childhood Development (ECD) into planning and management of cities is a matter of great concern in India.

Recognizing children as a national asset, Government of India (Gol) has initiated and taken up various programs, plans and policies, initiatives, flagship missions etc. to make cities more responsive and friendly from the perspective of children and their families, such as Smart City Mission (SCM) and Atal Mission for Rejuvenation and Urban Transformation (AMRUT) with focus on ensuring public safety in public spaces, streets, roads etc. especially for children, women and elderly along with promoting development of pedestrian areas, enhancement of cities by creating and upgrading green spaces, parks and recreation centers especially for children.

In addition to the above, the latest and recent ECD focused initiatives at national level are- 'Cycle4Change Challenge' and 'Street for People Challenge', 'Nurturing Neighbourhoods Challenge', initiatives of MoHUA in collaboration with other organization such as Institute for Transportation and Development Policy (ITDP) and Bernard van Leer Foundation (BvLF),

The National Institute of Urban Affairs (NIUA) has also undertaken a programme on building Child- Friendly Smart Cities (CFSC) to promote policies and practices to make Indian cities



Figure 1 Young kids & children are the most impacted one with Air Pollution

1 Census 2011
2 Census 2011

RFP for Development of three Child and Family-friendly junctions and 1.5km Connected shared Street at Saheli Marg and Big Bazar Rd, Udaipur, Rajasthan

child friendly within the urban agenda of building smart cities.

In the process, NIUA has also partnered with Bernard van Leer Foundation (BvLF) to develop a programme, known as 'Urban95' focusing on interventions and advocacy related to the needs of small children.

The goal of the project is to mainstream the needs of young children in Indian cities by addressing the gaps in Urban Planning & Design with objective of bringing greater awareness amongst urban planners and policy makers about the interrelationship between a young child's health and the built environment/ living conditions.

1.1 Urban95

Urban95 is BvLF's global initiative, aims to create healthy, prosperous, and vibrant cities where babies, toddlers and their families can thrive. The initiative is meant to make lasting change in the urban landscape and provide opportunities that can shape the crucial first five years of children's lives. The goal of this initiative is to support healthier, safer, and more exciting urban neighbourhoods for young children, for those who care for them, and for everyone.

1.2 Urban95 in India

Thriving and happy children are indicators of a healthy and sustainable society with high levels of well-being. Children form an understanding of their environment through everyday discoveries and encounters in the park, at school, during a stroll in neighbourhood or by imagining and inventing games and stories. The built environment plays a crucial role in shaping young children's narratives of the city, and their understanding and experience of urban spaces.

Realizing the need to address the issues surrounding the ITC, Bhubaneswar in Odisha, Pune in Maharashtra and Udaipur in Rajasthan became the part of the Urban95 program as a part of its Phase-I which was for 1 year period.

1.3 Urban95 in Udaipur

Realizing the need to transform its urban built environment into more Infant, Toddler, and their Caregivers (ITC) responsive and ITC friendly, Udaipur in Rajasthan has agreed to be part of Urban95 Program, and in process has join hands with BvLF via a formal Memorandum of Understanding (MoU). The Phase-I of the Program began in June 2019 for a period of 18 months and given the success of the same, Udaipur now has moved into larger and bigger phase starting Feb'21, planned for 36 months.

The focus of Urban95 Phase-II in on scaling up and sustainability of various projects through various "lighthouse" projects in neighbourhoods, streets and junctions, parks, and health facilities, incorporating Urban95 components in policy, enhance institutional capacities through trainings and peer learning, and build a broad coalition of support by involving relevant stakeholders in projects and other initiatives.

,

RFP for Development of three Child and Family-friendly junctions and 1.5km Connected shared Street at Saheli Marg and Big Bazar Rd, Udaipur, Rajasthan

SECTION 2: -UDAIPUR

Considered as one of the oldest cities in India and famous nationally and internationally as 'City of Lakes', Udaipur is the administrative capital of the district and is the only municipal corporation in the district with an area of 64 Sq km, divided into 70 election and revenue wards.

With the population 0.45 million³, city has 47932 young children population (0-6 years). The projected population for Udaipur in 2021 is estimated to be 0.83 million and 1.03 million in 2031⁴. The city has witnessed multi-fold development in the last two decades. It acts as an industrial, administrative, and educational center of the region. The city's connectivity and historic significance plays a major role in making it an important and famous city of the region and draws more than a million tourists annually⁵.

However, with increasing population and spread of the city, the overall quality of life is deteriorating for its citizens,

especially for children and their care-givers from pollution and noise pollution perspective, as with growing city needs, the pollution levels are rising at alarming pace and due to lot of construction activities and growing vehicular traffic the avg. decibel levels are at 75 DB⁶ which are way above the standard 55DB for neighbourhood levels.

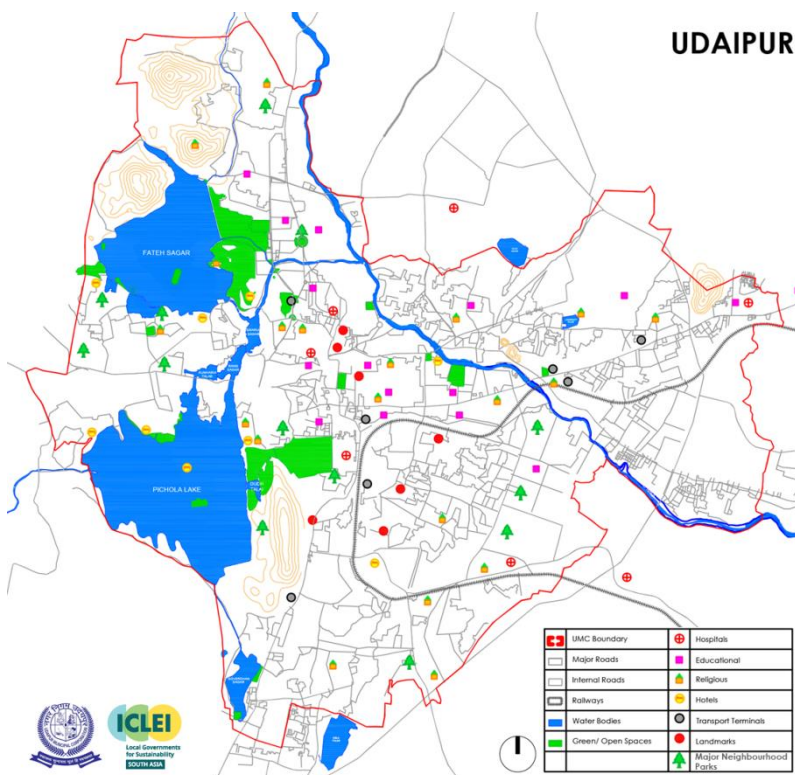

Figure 2 Municipal Area & Activity Mapping, Udaipur, Climate Action Plan for Udaipur, 2019-20, CapaCITIES

2.1 Demographics, Udaipur

Udaipur is the 6th largest city among cities having more than 1 lakh population in the state. The Municipal Corporation population accounts for 2.65% of the urban population of the state and 74.14% of the urban population of the district⁷.

The growing economy and growing tourism sector have attracted both urban as well as rural populace. The decadal growth rate from 2001 to 2011 was 15.83% which is near to natural growth rate of population. Areas outside the core city started developing during the last few years.

³ Census 2011;

⁴ Master Plan, Udaipur 2031;

⁵ Rajasthan Tourism Development Corporation (RTDC), Udaipur;

⁶ Low- Carbon Comprehensive Mobility Plan (LCMP), 2013- 41;

⁷ City-Development Plan (CDP), Udaipur 2014;

RFP for Development of three Child and Family-friendly junctions and 1.5km Connected shared Street at Saheli Marg and Big Bazar Rd, Udaipur, Rajasthan

SECTION 3: -INVITATION FOR BIDS (IFB)

E-NIT No. –.....

Dated:.....

The Commissioner, UMC, on behalf of Hon'ble Governor, Rajasthan state invites bids from eligible bidders of appropriate class registered with Rajasthan state / UTs or Other State Governments/ Central Government for the execution of the work mentioned in the table below on mode of contract.

| | |
|--|---|
| Name & Address of UDAIPUR MUNICIPAL CORPORATION (UMC) | Commissioner, Udaipur Municipal Corporation Town Hall, Udaipur, Rajasthan, India |
| Subject Matter of Procurement | Notice inviting Online Bids for Development of three Child and Family-friendly junctions and 1.5km Connected shared Street at Saheli Marg and Big Bazar Rd, Udaipur, Rajasthan |
| Approx. Value of the Project | INR ₹ 168.86 Lac |
| Period of Completion | 09 Months |
| Tender/Bid Document Fee (including GST) – To be deposited online/RTGS Transfer at UMC Bank Account No. | INR₹ 10,000 only |
| Period of On-line availability of Bid Documents (Start Date / End Date) | Start Date:..... End Date:..... |
| Pre-bid Meeting - Date and Time | Date/ Time: Place:Online: Interested bidders must send an email to commudr@gmail.com with copy to mcpnigamudaipur@rediffmail.com to receive a link for participation at least 01 day prior to the pre-bid meeting |
| Submission of Bids ,Manner, Date of Start - Submission & Time | Manner: Online, on e-Procurement website— Date of Start Time..... |
| End Date for Submission of Bids | End Date Time.....: |
| Date and Time of Opening of Technical Bid | Date..... & Time.....: |
| Bid Security/ Earnest Money Deposit (EMD) | INR₹ 3,38,000.00 |
| Physical Submission of EMD | *Shall be submitted till 01 day after the End date for submission of Bids* |
| Date and Time of opening of Financial Bid | Will be intimated later to the Technically Qualified Bidders |
| Bid Validity | 180 days from the Last Date of Bid Submission |
| Language | All the Communication for this RFP shall be in 'English' |

RFP for Development of three Child and Family-friendly junctions and 1.5km Connected shared Street at Saheli Marg and Big Bazar Rd, Udaipur, Rajasthan

- 3.1** The Bid documents consisting of Instructions to Bidders (ITB), Bid Data Sheet (BDS), Qualification Criteria and Documents to be furnished with the Bid, General & Special Conditions of Contract, Contract Data, Drawings, Specifications, and set of terms and conditions of contract and other forms will be uploaded on the **website:** The Bidders can download the bid documents from the specified date and time for sale.
- 3.2** Bids must be uploaded along with proof of having deposited cost of Bid Document. The bidder must possess Compatible Digital Signature Certificate (DSC) and proper user ID. The department does not take any responsibility for the delay caused due to non-availability of internet connection or network traffic jam etc.
- 3.3** Lowest Bidder (L-1) shall submit Hard Copy of Bid Document in the office of the Commissioner, UMC at the address given in the NIT within 05 (Five) days after the opening of Financial Bid.
- 3.4** A Bidder requiring any clarification of the bidding documents may ask questions online using the email given in NIT/ BD. The bidder shall have to send their queries one day prior to the Pre-Bid meeting. No queries will be entertained after the pre-bid meeting. Clarifications/ Responses to queries raised prior to pre-bid meeting and during the pre-bid will be uploaded on the e-tendering portal.
- 3.5** Technical Bids received on line shall be opened on **.....at.....** in the office of the Officer inviting bids at the address mentioned in the IFB in the presence of the bidders or their authorized representatives, who wish to be present. Bidders can witness the opening of bids after logging on to the site through their DSC. If the office happens to be closed on account of public holiday on the date of opening of the bids as specified, the bids will be opened on the next working day at the same time and venue.
- 3.6** Bids must be accompanied by bid security/ Earnest Money Deposit and cost of bid document of the amount as specified in the table above.
- 3.7** The payment for cost of bid document should be made online as per details given below: - Account Name: Udaipur Municipal Corporation (UMC)
- 3.8** Account No.
- 3.9** Bank Name: IFSC Code:
- 3.10** Conditional bids and the bids not meeting the qualifying criteria on the date of receipt of bids shall not be opened and shall be rejected.
- 3.11** The Employer reserves the right to cancel any or all bids without assigning any reason.

**Commissioner
Udaipur Municipal Corporation**

RFP for Development of three Child and Family-friendly junctions and 1.5km Connected shared Street at Saheli Marg and Big Bazar Rd, Udaipur, Rajasthan

SECTION 4: -INSTRUCTIONS TO BIDDERS (ITB) & BID DATASHEET (BDS)

A. GENERAL

4.1 Scope of Bid

4.1.1 In connection with the Invitation for Bids indicated in the Bid Data Sheet (BDS), the Employer, as indicated in the BDS, issues this Bidding Document for the procurement of works as specified in the BDS. The successful bidder shall have to complete the work by the date specified in the Invitation for Bids (Section-3).

4.1.2 Throughout this bidding document:

- a. The terms 'in writing' means communicated in written form and delivered against receipt.
- b. Except where the context requires otherwise, words indicating the singular also include the plural and words indicating the plural also include the singular; and
- c. "day" means calendar day.

4.2 Source of Funds

4.2.1 The expenditure on this project will be met from the funds as indicated in BDS.

4.3 Eligible Bidders

4.3.1 A Bidder may be a natural person, private entity or legally and financially autonomous Government owned enterprises.

4.3.2 This Invitation for Bid is open to all bidders registered with the Government of Rajasthan or other State Governments/Government of India for execution of Civil works in general. Joint Venture is allowed as per **Appendix A**.

4.3.3 All participating Bidders are required to register in the e-procurement portal. The Bidder intending to participate in the bidding is required to register in the portal using his/her active personal/official e-mail ID as his/her Login ID and attach his/her valid Digital Signature Certificate (DSC) to his/her unique Login ID. He/ She must submit the relevant information as asked for, about the firm/contractor.

4.3.4 A bidder shall not have conflict of interest. The bidder found to have a conflict of interest shall be disqualified. A bidder may be considered to have a conflict of interest with one or more parties in this bidding process in the following conditions: -

- a) they have controlling partner in common; or
 - b) they receive or have received any direct or indirect subsidy from any of them; or
 - c) they have the same legal representative for purposes of this bid; or
 - d) they have relationship with each other, directly or through common third parties, that puts them in a position to have access to information about or influence on the bid of another Bidder, or influence the decisions of the Employers regarding this bidding process; or
 - e) Bidder participates in more than one bid in the bidding process, then it will result in the disqualification of all the bids in which the bidder is involved or
 - f) Bidder or any of its affiliates participated as a consultant in the preparation of the
-

RFP for Development of three Child and Family-friendly junctions and 1.5km Connected shared Street at Saheli Marg and Big Bazar Rd, Udaipur, Rajasthan

- design or technical specifications of the contract that is the subject of the Bid; or
- g) Bidder, or any of its affiliates has been hired (or is proposed to be hired) by the Employer as Engineer for the contract.

4.4 Qualification of the Bidder

- 4.4.1** All bidders shall provide in Section 5, Qualification and other Information in the forms (Refer Section 12) provided for this purpose.
- 4.4.2** There is no prequalification requirement for participation in the bidding. However, the bidder shall have to fulfill all the requirements mentioned in this document under section 5.
- 4.4.3 Evaluation Requirements:** All bidders shall include the following information and submit documents with their bids as specified in Section 5, Qualification Information.
- a) Copies of documents defining the constitution or legal status, place of registration, and principal place of business, original written power of attorney of the signatory of the Bid.
 - b) Reports on the financial standing of the Bidder, such as turnover statements as per balance sheets, IT return and profit and loss statements duly audited and certified by the Chartered Accountant, for any three out of the last five years;
 - c) Total monetary value of construction works performed for each of the last five years, duly certified by the officer not below the rank of Executive Engineer or equivalent.
 - d) Details of works under way or contractually committed and clients who may be contacted for further information on those contracts;
 - e) Experience in works of a similar nature and size for each of the last five years and details of works under way or contractually committed certified by the officer not below the rank of Executive Engineer or equivalent.
 - f) Evidence of adequacy of working capital for this contract of at least 15 % of the advertised cost: Liquid assets and/or availability of credit facilities, Credit lines/letter of Credit/Certificate from banks for meeting the fund requirements of not less than the amount indicated in the BDS.
 - g) Authority letter to seek references from the Bidder's bankers;
 - h) Information regarding any litigation or arbitration resulting from contracts executed by the bidder in the last five years or currently under execution. The information shall include the names of the parties concerned, the disputed amount, cause of litigation, and matter under dispute;
 - i) Proposals for subcontracting components of the Works if any, amounting to not more than 25% percent of the Bid Price specified in the BDS (for each work, the qualifications and experience of the identified subcontractor in the relevant field should be annexed);
 - j) The Methodology of construction, Environmental Management Plan, Proposed Work Program, Quality Assurance Programme and Planned Value statement for the contract period supported with equipment planning and deployment, justifying their capability of execution and completion of the work within the stipulated period of completion as per milestones, if any, as mentioned in the Contract data
-

RFP for Development of three Child and Family-friendly junctions and 1.5km Connected shared Street at Saheli Marg and Big Bazar Rd, Udaipur, Rajasthan

(Section 7 of this document).

4.4.4 To qualify for award of the contract, the bidder must have in its name:

- a) Achieved, in any one financial year, a minimum annual turnover of amount indicated in the BDS, in the last five years as mentioned in the BDS.
- b) Participated and satisfactorily completed, as a prime contractor or as a nominated sub- contractor, at least one similar work of value not less than the amount indicated in BDS.
- c) Valid license for executing the proprietary works/ specialized job works and should have executed similar works for a minimum amount as indicated in BDS in any one year (or his identified sub-contractor should have the license).

4.4.5 To qualify for award of the Contract, the bidder should further demonstrate:

- a) Availability (either owned or leased or by procurement against mobilization advances) of the key and critical equipment for this work as indicated in Serial no (k) of Qualification Information, Section 5.
- b) Availability of key personnel with adequate experience as indicated in Serial no. (l) of Qualification Information, Section 5.

4.4.6 Sub-contractors' experience and resources shall not be taken into account in determining the bidder's compliance with the qualifying criteria for normal works. However, sub-contractors' experience and resources shall be required to be submitted by the bidder at Serial no. (i) of Qualification Information in Section 5, if the bidder wishes to propose sub-contracting for proprietary works/specialized job works.

4.4.7 Bidders who meet the minimum qualification criteria will be qualified only if their available bid capacity is more than the estimated project cost. The available bid capacity will be calculated as under

Assessed Available Bid capacity = (A*N*2.5-B+C)

A = Maximum value of construction works, excluding the amount of bonus received, executed in any one year during the last five years (updated to bid invitation year price level using the Updation factor given below considering the completed as well as works in progress.

N = Number of years (or fraction of a year) prescribed for completion of the works for which the present bid is invited.

B = Value, updated to the current price level, of existing commitments, including those for which date of commencement/appointed date has been declared, and on-going works to be completed during the period of completion of the works for which this bid is invited.

C = the amount of bonus received, if any, during the last 5 years.

The Bidder shall produce the statements of Ongoing works and Bonus Received countersigned by the Client/ Engineer -in Charge, not below the rank of Executive Engineer. The Factor for the year of Updation of price level is indicated below:

RFP for Development of three Child and Family-friendly junctions and 1.5km Connected shared Street at Saheli Marg and Big Bazar Rd, Udaipur, Rajasthan

| Year | Year-1 | Year-2 | Year -3 | Year-4 | Year-5 |
|-----------------|--------|--------|---------|--------|--------|
| Updation factor | 1.08 | 1.17 | 1.26 | 1.36 | 1.47 |

4.4.8 Even though the bidders meet the above qualifying criteria, they are subject to disqualification if they have:

- a) Made misleading or false representations in the forms, statements and attachment submitted in proof of the qualification requirements; and/or
- b) Record of poor performance such as abandoning the works, not properly completing the contract due to Contractor's failure, litigation history, or financial failures etc.

4.5 One Bid per Bidder

4.5.1 Each bidder shall submit only one bid for the project. Multiple bids participations will lead to disqualifications of all the bids in which the bidder has participated.

4.6 Cost of Bidding

4.6.1 The bidder shall bear all costs associated with the preparation and submission of his Bid, and the Employer will in no case be responsible and liable for those costs.

4.7 Site Visit

4.7.1 The Bidder, at the Bidder's own responsibility and risk is encouraged to visit and examine the Site of proposed Works and its surroundings and obtain all information that may be necessary for preparing the Bid and entering into a contract for construction of the proposed Works. The costs of visiting the Site shall be at the Bidder's own expense.

4.7.2 Hiding of any work in hand, that is subsequently established, shall be construed as the bidder's indulgence in "fraudulent practice" mentioned under clause 4.38, and actions shall be taken as mentioned in the same Section.

RFP for Development of three Child and Family-friendly junctions and 1.5km Connected shared Street at Saheli Marg and Big Bazar Rd, Udaipur, Rajasthan

B. BIDDING DOCUMENTS

4.8 Content of Bidding Documents

4.8.1 The set of bidding documents comprises the documents listed below and corrigenda / addenda issued.

| S/n | Particulars |
|-----|--|
| 3 | Invitation for Bids (IFB) |
| 4 | Instructions to Bidders (ITB) & Bid Data Sheet (BDS) |
| 5 | Information and documents to be submitted along with the Bid |
| 6 | Conditions of Contract |
| 7 | Contract Data |
| 8 | Scope of Work and Technical Specifications |
| 11 | Contract Forms |

4.8.2 The Bidder is required to login to the e-procurement portal and download the above listed documents from the website mentioned in BDS. He shall save it in his system, undertake the necessary preparatory work off-line, and upload the completed bid at his convenience before the closing date and time of submission.

4.9 Clarification on Bidding Documents and Pre-Bid Meeting

4.9.1 A bidder requiring any clarification on the bidding documents may ask questions on line in the e-procurement portal using his/her Digital Signature Certificate (DSC), within the time specified in the BDS prior (one day before Pre-Bid Meeting) to the date and time for submission of Bids.

4.9.2 The bidder or his official representative is invited to attend a pre-bid meeting which shall take place as indicated in the BDS. The purpose of the meeting is to clarify issues and to answer questions on any matter that relates to the bid. The bidder may submit any question in writing or by post or by email in the Format given below which shall be received by the Bid Inviting Officer prior to the date and time of the pre-bid meeting.

| Format of Sending Pre- Bid Queries | | | | | |
|---|---------------------|------------|----------|---|--|
| Name and Complete Official Address of Organization submitting Query/Request for Clarification | | | | | Telephone: |
| | | | | | Fax: |
| | | | | | Email: |
| S/n | Name of the Section | Clause No. | Page No. | Contents of RFP Requiring clarification | Change Requested/ Clarification Required |
| | | | | | |
| | | | | | |
| Signature | | | | | |
| Name of Authorized Signatory | | | | | |
| Company Seal & Date | | | | | |

RFP for Development of three Child and Family-friendly junctions and 1.5km Connected shared Street at Saheli Marg and Big Bazar Rd, Udaipur, Rajasthan

- 4.9.3** The Employer's response to the queries shall be posted in the portal without mentioning the identity of any bidder.
- 4.9.4** Any modification of the bidding documents listed in clause 4.8.1 which may become necessary as a result of the clarification, shall be made by the Employer through the issue of an Addendum/ Corrigendum pursuant to relevant clause(s) in the portal.

4.10 Amendment to Bidding Documents

- 4.10.1** Before the date for submission of bids, the Employer may modify the bidding documents by issuing corrigenda and addenda.
- 4.10.2** Any corrigendum or addendum thus issued shall be part of the bidding documents.
- 4.10.3** The corrigenda and addenda shall be published in the **E- proc website XXXXX**
- 4.10.4** To give reasonable time to the prospective bidders to take a corrigendum/addendum into account in preparing their bids, the Employer may extend, if necessary, the date for submission of bids.

RFP for Development of three Child and Family-friendly junctions and 1.5km Connected shared Street at Saheli Marg and Big Bazar Rd, Udaipur, Rajasthan

C. PREPARATION OF BIDS

4.11 Language of the Bid

4.11.1 All documents relating to the bid shall be in the English language only.

4.12 Documents comprising the Bid

4.12.1 The bid to be submitted by the bidder online (refer Clause 4.8.2 of ITB) shall be in two separate parts:

Part One: TECHNICAL PART

The Technical Part shall contain the following documents; the scanned copies thereof shall be uploaded on the portal:

- a) Proof of Bid document Fee Paid
- b) Proof of Bid Security Paid
- c) Details of Bidder
- d) Contractor's Letter for Bidding
- e) Power of Attorney
- f) Format for Evidence to access to Availability of Credit facility of at least 15% of advertised cost from a reputed bank.
- g) Affidavit regarding Abandoned Works and Undertaking
- h) Statement of Ethical Conduct, Fraud and Corruption
- i) Financial standing of the Bidder
- j) Construction Works completed during last five years
- k) Experience in works of similar nature and size during last three years
- l) Existing Commitments and ongoing works
- m) Copies of GST registration certificate and PERMANENT ACCOUNT NUMBER (PAN) from Income Tax Department
- n) Affidavit of correctness duly notarized.

All the pages of the submitted bid should be stamped and signed by the bidder/his authorized representative.

Part Two: FINANCIAL PART

- o) The Financial Part shall be filled properly in "The Letter for Financial Bid "and shall be submitted online only.
 - p) All duties, taxes (including GST as per prevailing rates), Labour cess and other levies including for possible future variations payable by the Bidder under the contract or for any other cause shall be included in the rates quoted by the contractor.
 - q) Rates quoted by the Bidder shall be fixed during the Bidder's performance of the contract and not subject to any variation on any account unless otherwise specified in the contract.
 - r) Rates shall be quoted in figures as well as in words. If any difference is found in figures and words, the rate in words shall be taken as valid and correct.
 - s) All the pages of the submitted bid should be stamped and signed by the bidder/his
-

RFP for Development of three Child and Family-friendly junctions and 1.5km Connected shared Street at Saheli Marg and Big Bazar Rd, Udaipur, Rajasthan

authorized representative.

t) Bid sent by e-mail or fax etc. shall not be considered.

Note: -

- The Financial Part of the bid cannot be merged with the Technical Part.
- Any Submission of hard copy/ scanned copy of the Financial Bid along with Technical Part shall lead to the rejection of the bid.

4.13 Bid Price

4.13.1 The Bidder shall bid for the whole work as described in the Scope of Work/ Summary sheet and detailed in Bill of Quantities.

4.13.2 All duties, taxes, and other levies payable by the Bidder under the contract, or for any other cause shall be included in the rates (including GST) prices and total Bid Price be submitted by the Bidder.

4.13.3 The rates and prices quoted by the Bidder shall remain fixed for the Contract period and shall not be subjected to any adjustments due to rise or fall in the market prices.

4.14 Currencies of Bid and Payment

4.14.1 The currency of bid and payment shall be quoted by the bidder entirely in Indian Rupees. All payments shall be made in Indian Rupees only.

4.15 Bid Validity

4.15.1 Bids shall remain valid for a period not less than period stated in the BDS after the last date for submission. A bid valid for a shorter period shall be rejected by the Employer as non-responsive.

4.15.2 In exceptional circumstances, prior to expiry of the original bid validity period, the Employer may request that the bidders may extend the period of validity for a specified additional period. The request and the bidders' responses shall be made in writing or by e-mail. A bidder may agree to or reject the request.

4.15.3 A bidder who has agreed to the Employer's request for extension of bid validity, in no case shall be permitted to modify his bid.

4.16 Bid Security/ Earnest Money Deposit (EMD)

4.16.1 The Bidder shall deposit along with its Bid, Bid Security for amount as shown in the IFB in Section 3. The Bid Security shall be deposited to UMC, Udaipur and may be in one of the following forms:

- a) Demand Draft payable at Udaipur
- b) Bank guarantee/ Fixed Deposit from any Nationalized Bank/ Scheduled Commercial Bank (Payable at Udaipur only), in the format approved by the Employer/ Engineer.

4.16.2 The Bid Security shall be valid for a period of thirty (30) days beyond the validity period of the Bid.

4.16.3 Bids not accompanied with Bid Security shall not be accepted and shall be rejected by

RFP for Development of three Child and Family-friendly junctions and 1.5km Connected shared Street at Saheli Marg and Big Bazar Rd, Udaipur, Rajasthan

the UMC as non-responsive.

4.16.4 In case of the Unsuccessful Bidders, the Bid Security will be returned to them without any interest, after expiry of the Bid validity period or not later than thirty (30) days after conclusion of the resultant contract whichever is earlier. The Successful Bidder's Bid Security will be returned without any interest, after receipt of Performance Security and Additional Performance Security from that Bidder.

4.16.5 Bid Security of a Bidder may be forfeited –

- a) if the Bidder withdraws or amends its Bid or impairs or derogates from the Bid in any respect within the period of validity of its Bid without prejudice to other rights of UMC; or
- b) In case of Successful Bidder, if the Bidder fails within the specified time limit to:
 - Sign the Agreement; or
 - Furnish the required Performance Security.

4.17 Alternative Proposals by Bidders

4.17.1 Conditional offers or alternative offers shall not be accepted.

4.18 Format & Signing of Bid

4.18.1 Bidders are to submit only the original BOQ (in excel format) uploaded by Bid Inviting Officer after entering the relevant fields without any alteration/ deletion/ modification. In case of item rate bid, bidders shall fill in their rates in the specified cells without keeping it blank.

4.18.2 Multiple BOQ submission by any bidder shall lead to cancellation of his/her bid.

4.18.3 The bidder shall upload the scanned copy/copies of document in support of eligibility criteria and qualification information in prescribed format in Portable Document Format (PDF) to the portal in the designated locations of Technical Bid. The Bidder shall ensure clarity/legibility of the document uploaded by him in the portal.

4.18.4 The bidder shall write his name in the space provided in the specified location in the BOQ.

4.18.5 The bidder shall log on to the portal with his/her DSC and move to the desired bid for uploading the documents in appropriate place one by one simultaneously checking the documents.

4.18.6 The Bid Inviting Officer shall not be responsible for any failure, malfunction or breakdown of the electronic system used during the e-procurement process.

4.18.7 The Bidder is required to upload documents related to his eligibility criteria and qualification information and Bill of Quantity duly filled in. It is not necessary for the Bidder to upload the drawings and the other Bid documents (after signing) while uploading his bid. It is deemed that the bidder has referred to all the drawings and documents uploaded by the Bid Inviting Officer. However, all these documents shall be submitted along with the hard copies.

**RFP for Development of three Child and Family-friendly junctions and 1.5km
Connected shared Street at Saheli Marg and Big Bazar Rd, Udaipur, Rajasthan**

4.18.8 Signing of Bid: The bidder shall digitally sign and stamp all pages of the bid, statements, documents, certificates uploaded by him, owning sole and complete responsibility for their correctness/authenticity as per the provisions of the IT ACT 2000.

RFP for Development of three Child and Family-friendly junctions and 1.5km Connected shared Street at Saheli Marg and Big Bazar Rd, Udaipur, Rajasthan

D. SUBMISSION OF BIDS

4.19 Date for Submission of the Bids

4.19.1 Bid shall be received ONLINE on or before the date and time mentioned in IFB/ BDS.

4.19.2 The Employer may extend the date for submission of bids by issuing an amendment in which case all rights and obligations of the Employer and the bidders previously subject to the original date will then be subject to the new date of submission.

4.20 Timeline for Submission of Bids

4.20.1 Bidder will not be able to submit his bid after expiry of the date and time of submission of bid (server time).

4.20.2 The date and time of bid submission shall remain unaltered even if the specified date for the submission of bids declared as a holiday for the Bid Inviting Officer.

4.20.3 All the bids uploaded by the Bidders to the portal will be encrypted. The encrypted Bids can only be decrypted/opened by the authorized persons on or after the due date and time.

4.20.4 Once submitted, the bid cannot be viewed, retrieved or corrected. The Bidder should ensure correctness of the bid prior to uploading and take print out of the system-generated summary of submission to confirm successful uploading of bid.

4.20.5 The submitted hard copies of the bid shall be acceptable only if the bidder has submitted his bid ONLINE also.

4.21 Late Bids

4.21.1 The Bidder will not be able to submit his bid after expiry of the date and time of submission of bid.

4.22 Modification, Resubmission and Withdrawal of Bids

4.22.1 Resubmission of bid by the bidders for any number of times before the date and time of submission is allowed. Resubmission of bid shall require uploading of all documents including price bid afresh. However, the last submitted ONLINE bid will only be considered for the purpose of evaluation.

4.22.2 The Bidder can withdraw his/her bid before the date and time of receipt of the bid by uploading scanned copy of a letter addressed to the Bid Inviting Officer citing reasons for withdrawal. The system shall not allow any withdrawal after the date and time of submission.

RFP for Development of three Child and Family-friendly junctions and 1.5km Connected shared Street at Saheli Marg and Big Bazar Rd, Udaipur, Rajasthan

E. BID OPENING AND EVALUATION

4.23 Bid Opening

- 4.23.1** Bids cannot be opened before the specified date & time, even by the Bid committee or the Procurement Officer or the Publisher.
- 4.23.2** Bid opening date and time is specified during bid creation or can be extended through corrigendum.
- 4.23.3** Opening of bids shall be carried out in the same order as it is occurring in invitation of bids or as in order of receipt of bids in the portal.
- 4.23.4** The Bid committee shall log-on to the portal to decrypt the bid submitted by the bidders. The bidders and guest users can view the summary of opening of bids from any system. Bidders are not required to be present during the bid opening at the opening location if they so desire.
- 4.23.5** In the event of the specified date of bid opening being declared a holiday, the bids will be opened at the same time on the next working day.
- 4.23.6** In case of all the bids being non-responsive, the Bid Committee shall complete the e-Procurement process by uploading the official letter for cancellation/re-bid.

4.24 Confidentiality

- 4.24.1** Information relating to the examination, clarification, evaluation, and comparison of Bids and recommendations for the award of a contract shall not be disclosed to Bidders or any other persons, not officially concerned with such process until the award has been announced in favour of the successful bidder.
- 4.24.2** Any effort by a Bidder to influence the Employer or any of his representatives during processing of bids, evaluation, bid comparison or award decisions shall be treated as Corrupt & Fraudulent Practices and may result in the rejection of his bid.

4.25 Clarification of Bids

- 4.25.1** To assist in the examination, evaluation, and comparison of bids, and qualification of the bidders; the Employer may ask the bidder/bidders for required clarification on the information submitted with the bid. The request for clarification and the response shall be sent by e-mail only. The Bidder will respond in not more than five calendar days from the date of issue of clarification letter. No change in the price or substance of the Bid shall be sought, offered, or permitted.
- 4.25.2** Subject to clause 4.24.1 no Bidder shall contact the Employer or any of his representatives on any matter relating to the submitted bid from the time of the bid opening to the time the contract is awarded. If the Bidder wishes to bring additional information to the notice of the Employer, he shall do so in writing.

4.26 Examination of Bids, and Determination of Responsiveness

- 4.26.1** During the detailed evaluation of "Technical Bid", the Employer will determine whether
-

RFP for Development of three Child and Family-friendly junctions and 1.5km Connected shared Street at Saheli Marg and Big Bazar Rd, Udaipur, Rajasthan

each bid

- a) Meets the eligibility criteria defined in Clause 4.3 of ITB;
- b) Meets the qualification criteria in accordance with the provision of Clause 4.4 of ITB; and is accompanied by the required bid cost and bid securing declaration form and the required documents mentioned under Clause 4.2 of Section 4.

4.26.2 A substantially responsive bid is one which conforms to all the terms, conditions, and requirements of the bidding documents, without material deviation or reservation. A material deviation or reservation is one

- a) Which affects in any way the scope, quality, or performance of the Works;
- b) Which limits in any way, inconsistent with the bidding documents, the Employer's rights or the Bidder's obligations under the Contract; or
- c) Whose implementation would affect unfairly the competitive position of other Bidders presenting responsive Bids.

4.26.3 If a Bid is not found responsive, it will be rejected by the Employer, and may not subsequently be made responsive by correction or withdrawal of the nonconforming material deviation or reservation.

4.26.4 Non-submission of legible documents may render the bid non-responsive.

4.27 Correction of Errors

4.27.1 The bid documents submitted ONLINE only shall be considered for the purposes of evaluation. As such, there shall be no arithmetical correction due to e-procurement processes.

4.27.2 In case of any difference in the documents / rates provided with hard copies and the documents / rates submitted ONLINE, the ONLINE submitted documents / rates shall be taken as correct.

4.28 Conversion to Single Currency

4.28.1 The bidder shall quote the prices in INR only.

4.29 Evaluations and Comparison of Responsive Bids

4.29.1 The Part-I containing Technical Part shall be opened first. The Bids will be taken up for evaluation with respect to the Qualification Information and other information furnished in Part-I of the Bid

4.29.2 All the opened bids shall be downloaded and printed for taking up evaluation. The Employer will evaluate and compare the Financial Bids and arrange the Financial Bids in order of their value for subsequent evaluation.

4.29.3 The bidder may be asked by email to clarify on the uploaded documents provided in the Technical Bid, if necessary, with respect to any doubts or illegible documents. The Bid Committee may ask for any other deficient document during technical evaluation of the bid; provided, in all such cases, furnishing of any document in no way alters the

RFP for Development of three Child and Family-friendly junctions and 1.5km Connected shared Street at Saheli Marg and Big Bazar Rd, Udaipur, Rajasthan

Bidder's price bid. Such clarifications shall not be asked more than once. The bidder shall respond within 03 (three) days of issue of the clarification letter failing which the bid of the bidder will be evaluated on its own merit.

4.29.4 The Technical evaluation of all the bids shall be carried out as per information furnished by Bidders.

4.29.5 The Bid Committee will evaluate bid and finalize list of responsive bidders.

4.29.6 UMC shall inform, by e-mail, the Bidders whose Technical Bids are found responsive i.e., Technically Qualified Bidders, about date time and place of opening of Part-II i.e., Financial Bid. In the event of the specified date being a holiday for UMC, the Bids will be opened at the appointed time and location on the next working day. The bidders or their representatives may attend the opening of Financial Bids. The Financial Bids of the technically responsive bidders shall be opened on the due date and time of opening. The Bid Committee shall log on to the system in sequence and open the Financial Bid. At the time of opening of "Financial Bid", bidders, whose Technical Bids were found responsive, may be present.

4.29.7 Bidder can witness the principle activities and view the documents/summary reports for that particular work by logging on to the portal with his DSC anywhere.

4.29.8 The estimated effect of the price adjustment conditions, if any, under Clause 6.25.13 of the Conditions of Contract, during the period of implementation of the Contract, will not be taken into account in Bid Evaluation.

4.29.9 If the Bid of the successful Bidder is seriously unbalanced in the opinion of the Employer by more than 25 % in relation to the Employer's estimate for the work to be performed under the contract, the Employer will require the Bidder to produce detailed price analyses for any or all items of the Bill of Quantities, and/or to demonstrate the internal consistency of these prices with the construction methods and schedule proposed. The bidder shall respond in not more than seven number of days of issue of the clarification letter as mentioned in BDS, failing which the bid of the bidder will be evaluated on its own merit.

In cases of such unbalanced bids, the Employer will require that the amount of the performance security be increased at the expense of the successful Bidder to a level sufficient to protect the Employer against financial loss in the event of default of the successful Bidder under the Contract.

4.30 The extent of the Additional Performance security shall be as per the following ceiling: -

- a) Percentage rate up to and including 15% below the advertised / estimated cost-normal performance security.
 - b) Percentage rate quoted beyond 15% below up to and including 25% below: Additional 5.0% of the accepted contract cost.
 - c) Percentage rate quoted beyond 25% below up to and including 35% below: Additional 7.5% of the accepted contract cost.
 - d) A bid which is quoted beyond 35% below the advertised/estimated cost: Additional
-

RFP for Development of three Child and Family-friendly junctions and 1.5km Connected shared Street at Saheli Marg and Big Bazar Rd, Udaipur, Rajasthan

10.0% of the accepted contract cost.

4.31 Negotiation of Bids

4.31.1 After examination, evaluation, and comparison of bids, the Bid Committee may, at its discretion, call the lowest bidder (L1) for negotiation on construction methodology, works programme, deployment of personnel, plant and machinery for construction etc.

4.31.2 Special attention shall be paid to optimize the required output from the lowest bidder to define clearly the inputs required from the employer to ensure satisfactory implementation of the assignment.

4.32 Award of Contract

4.32.1 Award Criteria.

- a) Subject to this Clause, the Employer will award the Contract to the Bidder whose bid has been determined to be responsive and who has offered the lowest evaluated bid price.
- b) In the eventuality of failure on the part of the successful bidder to submit the performance security within the stipulated time, the Bidder shall be debarred in future from participating in all the Bids from any Government owned agency/ corporation/Employer/special purpose vehicle, for three years and will be recommended for blacklisting by the competent Employer. In such a situation, the next successful bidder will be required to produce his Performance Security for consideration of his bid at the negotiated rate equal to lowest bidder, otherwise the tender will be cancelled.

4.33 Employer's Right to Accept any Bid and to Reject any or all Bids.

Notwithstanding Clause 4.31.1 the Employer reserves the right to accept or reject any Bid and to cancel the Bidding process and reject all Bids at any time prior to the award of Contract, without assigning any reason thereof and without thereby incurring any liability to the affected Bidder or Bidders or any obligation to inform the affected Bidder or Bidders of the grounds for the Employer's action.

4.34 Notification of Award and Signing of Agreement.

- a) The Bidder, whose Bid has been accepted, shall be notified of award by the Employer prior to expiration of the Bid validity period by email /courier. This letter (hereinafter and in the Conditions of Contract called the "Letter of Award") will state the sum that the Employer will pay to the Bidder in consideration of the execution, completion and remedying defects of the Works by the Contractor as prescribed by the Contract (hereinafter and in the Contract called the "Contract Price").
 - b) The notification of award will constitute the formation of the Contract, subject only to the furnishing of a performance security in accordance with the provisions of Clause 4.35 within 07 days of issue of letter of award.
 - c) A detailed Works Program showing the general methods, arrangements, order and timing for all the activities in the Works along with quarterly planned value statement and milestone wise details of works shall be submitted within 14 days from the date of
-

RFP for Development of three Child and Family-friendly junctions and 1.5km Connected shared Street at Saheli Marg and Big Bazar Rd, Udaipur, Rajasthan

signing of the contract.

- d) The Agreement will incorporate all agreements between the Employer and the successful Bidder. It will be signed by the Employer and kept ready for signature of the successful bidder in the office of the Employer within 28 days following the issue of the Letter of Award.
- e) Upon the furnishing by the successful Bidder of the Performance Security, the Employer will promptly notify the other Bidders that their Bids have been unsuccessful.

4.35 Performance Security

- a) Within 07 (seven) days of receipt of the Letter of Award, the successful Bidder shall deliver to the Employer a Performance Security in the form of irrevocable, unconditional Bank Guarantee valid for a period as stipulated in Clause 6.25.18 of Conditions of Contract & in the Contract Data for an amount equivalent to a percentage of the Contract price as mentioned in BDS.
- b) The performance security is to be provided by the successful Bidder in the form of unconditional, irrevocable Bank Guarantee, from a **Nationalized Bank/ Scheduled Commercial Bank**, whose Udaipur Branch shall be clearly authorized to pay the claim on demand by the Employer.
- c) In the event of the successful Bidder failing to comply with the requirements of Sub Clause 4.35a, such a failure shall constitute a breach of contract and, cause for annulment of the award and any such other remedy the Employer may take under the contract, and the Employer may resort to awarding the contract to the next ranked bidder.

4.36 Advance Payment and Security

The Employer will provide an Advance Payment/ Mobilization Advance on the Contract Price as stipulated in the Conditions of Contract, subject to maximum amount, as stated in the Contract Data.

4.37 Dispute Resolution

In case of disputes, the bidder shall approach the Commissioner, UMC for resolution of his grievance or point of dispute. If the Bidder is not satisfied with the decision of the Commissioner, UMC, then the Bidder as the aggrieved party can request the dispute be referred for arbitration by the Arbitral Tribunal consisting of the sole Arbitrator to be nominated by the Commissioner, UMC, who will resolve the dispute through provisions of Arbitration & Conciliation Act, 1996.

4.38 Corrupt or Fraudulent Practices.

It is required that the bidders observe the highest standard of ethics during the procurement and execution of this contract. In pursuance of this policy, it is defined, for the purposes of this provision, the terms set forth below as follows:

- I. "Corrupt practice" means the offering, giving, receiving or soliciting of anything of value to influence the action of a public official in the procurement process or in contract execution; and
 - II. "Fraudulent practice" means a misrepresentation of facts in order to influence a
-

RFP for Development of three Child and Family-friendly junctions and 1.5km Connected shared Street at Saheli Marg and Big Bazar Rd, Udaipur, Rajasthan

procurement process or the execution of a contract to the detriment of the Employer and includes collusive practice among Bidders (prior to or after bid submission) designed to establish bid prices at artificial non-competitive levels and to deprive the Government of the benefits of free and open competition.

- III. "Collusive practice" is an arrangement between two or more parties designed to achieve an
 - IV. improper purpose, including to influence improperly the actions of another party;
 - V. "Coercive practice" is impairing or harming, or threatening to impair or harm, directly or indirectly, any party or the property of the party to influence improperly the actions of a party.
- a) The Employer will reject a proposal for evaluation, and/or award if it determines that the Bidder recommended for award has engaged in any of the corrupt or fraudulent practices in competing for the contract in question and will declare the firm ineligible, either indefinitely or for a stated period of time, to be awarded a contract, if it at any time determines that the firm has engaged in corrupt or fraudulent practices in competing for, or in executing the contract.
 - b) Furthermore, Bidders may be aware of the provision stated in Clause 6.27.1 of the Conditions of Contract.

RFP for Development of three Child and Family-friendly junctions and 1.5km Connected shared Street at Saheli Marg and Big Bazar Rd, Udaipur, Rajasthan

Appendix A

1. **Joint Venture:-** If the bidder is a Joint Venture, the partners would be limited to two (including lead partner). Joint Venture firm shall be jointly and severally responsible for completion of the project.
2. Joint Venture must fulfill the following minimum qualification requirement:-
 - I. The lead partner shall meet not less than 51% of qualification criteria given in clause 4.4 of ITB of this bidding document.
 - II. Non-lead partner shall meet not less than 25% of all the qualification criteria given in sub- clause 4.4 of I.T.B of this bidding document to be part of JV. Irrespective of proportion of partnership in proposed JV Agreement.
 - III. The Joint Venture must also collectively satisfy the Criteria of clause 4.4 of ITB for this purpose the relevant figures for each of the partners shall be added together to arrive at the Joint Venture total capacity which shall be 100% or more.
 - IV. In the event that the Employer has caused to disqualify under clause 4.4.7 of ITB all of the Joint Venture partners will be disqualified.
 - V. Joint Venture applicants shall provide a certified copy of the Joint Venture agreement in demonstration of the partners undertaking joint and several liabilities for the performance of any contract entered into before award of work.
 - VI. The available bid capacity of the Joint Venture as required under clause 4.4.7 of ITB will be applied for each partner to the extent of his proposed participation in the execution of the work .The total Bid Capacity available shall be more than estimated contract value.

Bids submitted by a Joint Venture (JV) of not more than two firms as partners shall comply with the following requirements:

- a) A copy of the Joint Venture agreement shall be submitted at the time of submission of bid. The joint venture agreement shall be duly registered by first class Munsiff.
 - b) Lead Partner shall be nominated as being partner in-charge; and this authorization shall be evidenced by submitting a power of attorney signed by legally authorized signatories of all the partners.
 - c) The partner in-charge shall be authorized to incur liabilities and to receive instructions for and on behalf of partners of the joint venture, whether jointly or severally, and entire execution of the Contract (including payment) shall be carried out exclusively through the partner-in-charge
 - d) A copy of the said authorization shall be furnished in this Bid.
 - e) All partners of the Joint Venture shall be liable jointly and severally for the execution of the Contract in accordance with the Contract terms and relevant statement to this effect shall be included in the authorization mentioned sub-clause(c) above as well as in the Form of Tender and the Form of Agreement (in case of successful bidder).
 - f) All the partners of the Joint Venture will retain the full and undivided responsibilities for the performance of their obligations under the Contract and/or for satisfactory completion of the works.
 - g) The bid submitted shall include all the relevant information as required under
-

RFP for Development of three Child and Family-friendly junctions and 1.5km Connected shared Street at Saheli Marg and Big Bazar Rd, Udaipur, Rajasthan

provisions of Sub clause 1 & 2 of Appendix-A of ITB and furnished separately for each partner.

| BID DATA SHEET (BDS) | | |
|--|---|--|
| The Employer shall fill up all the details required in the BDS | | |
| A. Introduction | | |
| ITB 4.1 | Scope of Bid | E-NIT No. – _____ Dated: _____ |
| | | The Employer: Commissioner, Udaipur Municipal Corporation (UMC) |
| | | Name of the Project: Development of three Child and Family-friendly junctions and 1.5km Connected shared Street at Saheli Marg and Big Bazar Rd, Udaipur, Rajasthan |
| ITB 4.2 | Source of Funds | Udaipur Municipal Corporation (UMC) |
| | Approx. value of the Project | INR ₹ 168.86 Lac |
| ITB 4.4.3 | Evaluation Requirements (Sub Contracting) | The bidder shall not propose to sub-contract elements of the works amounting to more than 25% of the bid price. <i>(For each such proposal, the qualification and the experience of the identified subcontractor in the relevant field should be furnished along with the bid to enable the employer to satisfy himself about their qualifications before agreeing for such sub-contracting and include it in the contract)</i> |
| ITB 4.4.3 | Evaluation Requirement | |
| | Credit Facility from a Reputed Bank | 15 % of the advertised cost |
| | Turnover | INR 85 Lac (50% of the total project cost) |
| B. Bidding Documents | | |
| ITB 4.8.2 | Web Address | http://www.XXXXXXX.gov.in |
| ITB 4.9.1 | | Prior to the Date of Pre-Bid meeting |
| ITB 4.9.2 | Pre bid meeting | Date/ Time: Place:..... Interested bidders must send an email to commudr@gmail.com with copy to mcpnigamudaipur@rediffmail.com to receive a link for participation at least 01 day (before 24 hours) prior to the pre-bid meeting |
| C. Preparation of Bids | | |
| ITB 4.13 | Bid Price | Price adjustment: Not applicable. |
| ITB 4.15 | Bid Validity | 180 days from the Last date of Bid submission. |
| D. Submission of Bids | | |
| ITB 4.19 | Submission of Bids | The date and time for bid submission online is: Date: _____ Time: _____ |

RFP for Development of three Child and Family-friendly junctions and 1.5km Connected shared Street at Saheli Marg and Big Bazar Rd, Udaipur, Rajasthan

| E. Bid Opening and Evaluation | | |
|-------------------------------|-----------------------------|---|
| ITB 4.22 | Bid Opening | Date/ Time: Venue: Office of the Commissioner UMC, Udaipur Municipal Corporation (UMC) Limited C/ o Commissioner, Udaipur Municipal Corporation, Town Hall, Udaipur. |
| ITB 4.34.a | Performance Security | 10 % of the Accepted Contract Cost |
| ITB 4.30 | | The extent of the Additional Performance security shall be as per the following ceiling: - <ol style="list-style-type: none"> a. Percentage rate up to and including 15% below the advertised / estimated cost- normal performance security. b. Percentage rate quoted beyond 15% below up to and including 25% below: Additional 5.0% of the accepted contract cost. c. Percentage rate quoted beyond 25% below up to and including 35% below: Additional 7.5% of the accepted contract cost. d. A bid which is quoted beyond 35% below the advertised/estimated cost: Additional 10.0% of the accepted contract cost. <p><i>Note: The Additional performance security shall be released after the physical completion of the project or issuance of completion certificate.</i></p> |

RFP for Development of three Child and Family-friendly junctions and 1.5km Connected shared Street at Saheli Marg and Big Bazar Rd, Udaipur, Rajasthan

SECTION 5: QUALIFICATION INFORMATION

Information and Documents to be furnished along with the bid*

(The Bidder shall submit all the documents indicated below, in complete shape in the prescribed appendices.

| | |
|----------|--|
| A | CONTRACTOR'S BID |
| B | PROOF OF COST OF BID DOCUMENT |
| C | MINIMUM ELIGIBILITY CRITERIA |
| D | QUALIFICATION INFORMATION |
| E | BID-SECURING DECLARATION |
| F | EVIDENCE OF CREDIT FACILITY |
| G | DECLARATION REGARDING BLACKLISTING/ DEBARRING/ ABANDONED WORKS |
| H | STATEMENT OF ETHICAL CONDUCT, FRAUD AND CORRUPTION |

5.1 Bid Submission Form

(Please refer to Appendix 2)

(To be filled in by the Bidder and submitted along with the offer)

5.2 Proof of Cost of Bid Document

(The Contractor shall pay the cost of bid document in the manner as specified in the IFB and submit its proof.)

5.3 Minimum Eligibility Criteria/ Qualification Criteria

| S/n | Criteria | Documentary Evidence Required |
|-----|--|---|
| 1 | Bidder should be a sole proprietorship/ Company/ Partnership firm/ LLP registered in India under Companies Act 2013/ LLP Act 2008/ Society Act/ contractors registered with Rajasthan Govt. and other states/Central Govt. or as amended and should have been in operation in India. | Enclose copy of Certificate of Incorporation/ Registration under Companies Act 2013/ LLP Act 2008/ Society Act and Copy of PAN Card. |
| 2 | The Bidder must have a valid EPF and ESI Registration. | Copies of registration to be enclosed with Bid. |
| 3 | The Bidder should have a valid GST number or should have registered under GST. | Enclose copy of GST Registration Certificate |
| 4 | Bidder must have in the last 05 (FIVE) years preceding the last date of submission of Bids should have completed: (for composite work) a) One single similar work costing not less than 80% of the estimated value of the work OR b) Two similar works costing not less than 50% each of the estimated value of the work OR c) Three similar works costing not less than 40% each of the estimated value of the work Note: Similar works mean Civil & Urban infrastructure works. | a) Details to be provided as per Appendix 11 b) The requisite completion / performance certificate received from the client shall be furnished with Bid Along with the contact details of the client from an officer not below the rank of Executive Engineer or equivalent. |

RFP for Development of three Child and Family-friendly junctions and 1.5km Connected shared Street at Saheli Marg and Big Bazar Rd, Udaipur, Rajasthan

| | | |
|---|---|--|
| 5 | <p>Bidder must have:</p> <ol style="list-style-type: none"> I. Positive Net Worth in the Financial Year preceding Bid Submission Date II. Should have an Average Annual turnover of INR 85 Lac (50% of project cost) of total Project Cost during any three out of last 5 financial years (i.e., FY 2018-19, 2019-20 & 2020-21, 2021-22, 2022-23) immediately preceding the current Financial Year. III. Bidder should have ISO 9001: 2015 Certification accredited by IAF (International Accreditation Forum). IV. The Bidders' Available Bid capacity should be more than the Estimated Project Cost. <p>The Available Bid Capacity shall be calculated as per the formula: Assessed Available Bid capacity = (A*N*2.5-B+C) A = Maximum value of construction works executed in any one year during the last five years (updated to bid invitation year price level based on approved annual inflation rate considering the completed as well as works in progress. N = Number of years (or fraction of a year) prescribed for completion of the works for which the present bid is invited. B = Value, at the current price level, of existing commitments and on-going works to be completed during the period of completion of the works for which bid is invited. C=The amount of bonus received, if any, during the last 5 years</p> | <p>Details to be provided as per Format of the Bidding Document; Copies of balance sheets and statement(s) featuring turnover during the aforesaid periods should be submitted duly signed by the Bidder and the Chartered Accountant concerned, as applicable.</p> <p>Availability of Letter of Credit from a reputable bank. Certificate from Chartered Accountant showing the calculation of assessed available bid capacity of the bidder.</p> |
| 6 | <p>The Bidder should not have been debarred/blacklisted by any State Government/UTs/ Central Government/ PSU/ UMC)/ Government authority in India for any reason and the same subsists as on Bid Submission Date.</p> | <p>Enclose blacklisting/ debaring declaration. (Refer the contract Form section)</p> |

Note: Bidders who meet all the requirements set forth above and provide the qualification documents as specified, only shall be considered further in the Bidding Process.

| Year | Year-1 | Year-2 | Year -3 | Year-4 | Year-5 |
|------------------------|--------|--------|---------|--------|--------|
| Updation factor | 1.08 | 1.17 | 1.26 | 1.36 | 1.47 |

Hiding of any work in hand, which should be considered as part of B in the Bid Capacity assessment that is subsequently established, shall be construed as the bidder's indulgence in "fraudulent practice"

RFP for Development of three Child and Family-friendly junctions and 1.5km Connected shared Street at Saheli Marg and Big Bazar Rd, Udaipur, Rajasthan

Qualification Information

[The information shall be filled in by the Bidder in the tables as given in Appendices at the end of Bid Document which shall be used for purpose of evaluation as provided for in Clause 4.4.3 of the Instructions to Bidders.]

a) Statement of compliance under the requirements of Sub Clause 4.27 of the Instructions to Bidders. Copy of Registration Certificate (Renewed up to date) be produced.

b) For Individual Bidders (Sub Clause 4.4.3 (a) of Instructions to Bidders may be referred to Constitution or legal status of Bidder: [Attach copy]

Place of registration:

Principal place of business:

Name of Authorized Signatory of Bid:

Power of Attorney of Signatory of Bid: Appendix 4 [Attach original document]

c) Copies of reports on the financial standing of the Bidder, such as turnover statements as per IT return, Balance Sheet and Profit & Loss statements duly certified by a Chartered Accountant for any three out of the last five years as stated under Clause 4.4.3 (b) of Instructions to Bidders. (Appendix 9)

d) Total monetary value of construction works completed in the last five years as stated under Sub Clause 4.4.3(c) of Instructions to Bidders duly certified by the officer not below the rank of Executive Engineer or equivalent. (Appendix 10)

e) Experience in works of a similar nature and size for each of the last five years (i.e., FY 2018-19, 2019-20 & 2020-21, 2021-22, 2022-23) and details of works under way or contractually committed and clients who may be contacted for further information on those contracts. Sub Clause.4.4.3 (e) of Instructions to Bidders may be referred to

i. Experience in works of a similar nature and size: (Appendix 11)

ii. Existing commitments and on-going works (Appendix 12)

*Attach certificate (s) from the Engineer(s)-in-Charge, not below the rank of Executive Engineer regarding all completed works and Attach documentary evidence for the same.

f) Evidence of access to financial resources to meet the qualification requirements: cash in hand, lines of credit, etc. List them below and attach copies of support documents in the attached format provided in this Section. (Sub Clause.4.4.3(f) of Instructions to Bidders may be referred to)

g) Name, address, e- mail id, telephone and fax numbers of the Bidders' Bankers who may provide references if contacted by the Employer. Sub Clause.4.4.3(g) of Instructions to Bidders may be referred to

| S/n | Name of the Bank | Address | Telephone No. | FAX no. | e-mail id |
|-----|------------------|---------|---------------|---------|-----------|
| 1 | 2 | 3 | 4 | 5 | 6 |

h) Information on litigation history in which the Bidder is involved (Sub Clause pdv 4.4.3. (h) of Instructions to Bidders may be referred to)

| Other Part(ies) | Employer | Cause of Dispute | Amount involved | Remarks showing present status |
|-----------------|----------|------------------|-----------------|--------------------------------|
| | | | | |

RFP for Development of three Child and Family-friendly junctions and 1.5km Connected shared Street at Saheli Marg and Big Bazar Rd, Udaipur, Rajasthan

| | | | | |
|--|--|--|--|--|
| | | | | |
| | | | | |

i) Proposed subcontracts and firms involved. (Sub Clause 4.4.3(i) of Instructions to Bidders may be referred to)

| Section/ Items/ Nature of the works | Value of The Proposed Sub Contract | Details of Subcontractor (Name, Address, Phone No., E-mail id) | Copies of Experience Certificate @ in similarwork | Copies of valid license attached% | Consent of the proposed Sub-Contractor Attached |
|-------------------------------------|------------------------------------|--|---|-----------------------------------|---|
| | | | Yes/ No | Yes/ No | Yes/ No |
| | | | | | |
| | | | | | |
| | | | | | |

j) The proposed methodology and program of construction (Sub Clause 4.4.3(j)- of Instructions to Bidders may be referred to)

| | | |
|------|-----------------------------|-----------------------|
| i. | Work Program | Attached/Not Attached |
| ii. | Methodology | Attached/Not Attached |
| iii. | Plan value Statement | Attached/Not Attached |
| iv. | Environment Management Plan | Attached/Not Attached |
| v. | Quality Assurance Programme | Attached/Not Attached |

k) Major items of construction equipment proposed to carry out the Contract:

[The Bidder must list all the information requested below. Refer also to Sub Clause 4.4.4(a) of the Instructions to Bidders.]

- I. The type and minimum numbers of key plants & equipment shall be specified by the bidder depending upon type of works requirement.
- II. The Bidder shall provide documentary evidence in support of their possession of plants and equipment as per site requirement.
- III. For machineries/ equipment to be arranged on hiring/lease basis, the bidder shall provide details of such arrangement, which shall form a part of the qualification of the bidder.
- IV. Machineries, older than 5 years or in poor working condition, shall be reconditioned/ repaired to improve the performance level. Such machinery shall pass the test of satisfactory performance by an appropriate authority contracted by the Employer.

Attach copies of experience certificates of similar nature of work from Employers of the Sub-Contractor. % Attach copies of certificates of possession of valid license for executing the specialized work (Like Water supply & Sanitary work / Electrification works/ Civil works/ Proprietary works/ Specialized Job works) + Consent of the proposed* Sub-Contractor to complete the work in all respects must be attached in original.

RFP for Development of three Child and Family-friendly junctions and 1.5km Connected shared Street at Saheli Marg and Big Bazar Rd, Udaipur, Rajasthan

| S/n. | Type of Equipment | Minimum Requirement for the works | | Availability / arrangement with the bidder | | | | |
|------|-------------------|-----------------------------------|----------|--|----------|--|---------------------------------|-----------|
| | | Nos. | Capacity | Nos. | Capacity | Registration. No. / Identification No. | Owned / Leased / To be procured | Condition |
| (1) | (2) | (3) | (4) | (5) | (6) | (7) | (8) | (9) |
| 1 | [...] | [.....] | [.....] | | | | | |
| 2 | [...] | [.....] | [.....] | | | | | |
| ... | [...] | [.....] | [.....] | | | | | |

l) Qualifications and experience of key personnel proposed for administration and execution of the Contract. [The Bidder must list all the information requested below. Refer also to Sub Clause 4.4.4(b) of the Instructions to Bidders.]

| S/n | Position | Qualification | software Proficiency | Total Work Experience (years) | Experience in Similar Position(years) | Experience with the Bidding Firm (Desirable) |
|-----|--|---|----------------------|-------------------------------|---------------------------------------|--|
| 1 | Project Manager | B.E. / B. Tech. Civil | Word/ Excel | As Required | As Required | As Required |
| 2 | Material/ Quality Control Manager | Degree/ Diploma (Civil) | Word/ Excel | As Required | As Required | As Required |
| 3 | Quantity Surveyor | Diploma Civil | HDM-4, Excel Word | As Required | As Required | As Required |
| 4 | Site Engineers | Degree/ Diploma (Civil-02 nos./ Electrical-01 no) | Word, Excel | As Required | As Required | As Required |
| 5 | Any Others as Deemed | | | | | |

NOTE: The lists of professionals listed above are considered as the minimum required for executing the project successfully. The Bidder shall provide CVs of proposed personnel listed above. During construction if the need arises to replace any of the staff, equivalent or more experienced persons should be proposed as replacement. Non deployment of above professionals will lead to the breach of contract.

RFP for Development of three Child and Family-friendly junctions and 1.5km Connected shared Street at Saheli Marg and Big Bazar Rd, Udaipur, Rajasthan

SECTION 6: CONDITIONS OF CONTRACT

6.1 GENERAL

6.1.1 Definitions

Terms, which are defined in the Contract Data, are not defined in the Conditions of Contract but keep their defined meanings. Defined terms are shown in bold letters.

6.1.2 Bill of Quantities

Bill of quantities means the priced and completed items of work as per Summary of works with the BOQ.

6.1.3 Compensation Events

The Compensation Events are those defined in Clause 6.25.1 of Conditions of Contract here under.

6.1.4 Clarification of Bids

6.1.4.1 To assist in the examination, evaluation, and comparison of bids, and qualification of the bidders; the Employer may ask the bidder/bidders for required clarification on the information submitted with the bid. The request for clarification and the response shall be sent by e-mail only. The Bidder will respond in not more than five calendar days from the date of issue of clarification letter. No change in the price or substance of the Bid shall be sought, offered, or permitted.

6.1.4.2 Subject to clause 4.24.1, no Bidder shall contact the Employer or any of his representatives on any matter relating to the submitted bid from the time of the bid opening to the time the contract is awarded. If the Bidder wishes to bring additional information to the notice of the Employer, he shall do so in writing.

6.1.5 Completion Date

This is the date by which the Contractor is contractually obliged to complete the works, taking account of award of any EOTs. As well as being an overall date for completion, the contract completion date may be the date for completion of a section of works or a milestone date.

6.1.6 The Intended Completion Date

The Intended Completion Date is the date on which it is intended that the Contractor shall complete the Works. The Intended Completion Date is specified in the Contract Data. The Intended Completion Date may be revised only by the Employer by issuing an extension of time.

6.1.7 Substantial completion

When the Work is completed to an extent that it is fit for its intended purpose, in accordance with the construction contract, i.e., it can be fully put to its intended use and only less than 05% percent of the contract value remains to be executed, the Works is stated to be substantially complete.

RFP for Development of three Child and Family-friendly junctions and 1.5km Connected shared Street at Saheli Marg and Big Bazar Rd, Udaipur, Rajasthan

6.1.8 The Contract

- a) The Contract is the contract between the Employer and the Contractor, to execute, complete and maintain the Works. It consists of the documents listed in Clause 6.2.3 below.
- b) The Contractor's Bid is the completed Bid as per the requirements shown in instructions to Bidders, submitted by the Contractor to the Employer and includes Technical and Contract.
- c) The Contract Data defines the documents and other information, which comprise the Contract Price is the price stated in the Letter of Award and thereafter as adjusted in accordance with the provisions of the Contract.
- d) The Contract Period means works execution period including the Defects Liability Period as given in the Contract Data. The Contract Period will begin from the date of signing of the Contract and will end with successful taking over by the Employer It will also include any time extensions given by the Employer
- e) Days are calendar days; months are calendar months.

6.1.9 The Contractor

The Contractor is a person or corporate body whose Bid to carry out the Works that has been accepted by the Employer.

6.1.10 Subcontractor

A Subcontractor is a person or corporate body who has a Contract with the Contractor to carry out a part of the work in the Contract, which includes work on the Site.

6.1.11 Critical Path

The Critical path is the longest sequence of activities through a project network from start to finish, the sum of whose durations determines the overall project duration. A delay to progress of any activity on the critical path will, without acceleration or re-sequencing, cause the overall project duration to be extended, and is therefore referred to as a 'critical delay'.

6.1.12 Critical Path analysis

It is the process of analysing the critical or near critical activities in a Critical Path Method (CPM) programme to manage progress, balance resource allocations and ascertain delays or acceleration to the date for completion or the completion date of the Works, a section or a milestone.

6.1.13 Critical Path method (CPM)

CPM calculates a project's duration from start to finish and identifies the critical path of that project. The critical path is the set of activities that cannot be delayed; otherwise, the entire project is at risk of completing late.

6.1.14 Delay

Delay is the time lag in actual completion of activities compared to what was planned.

RFP for Development of three Child and Family-friendly junctions and 1.5km Connected shared Street at Saheli Marg and Big Bazar Rd, Udaipur, Rajasthan

6.1.15 Contractor Risk Event

An event or cause of delay or disrupt under the contract is at the risk and responsibility of the Contractor under the contract clause.

6.1.16 Contractor Delay

The expression Contractor delay is used to describe any delay caused by a Contractor Risk Event. A contractor delay to progress is a delay which will merely cause delay to contractor's progress without impacting the contract completion date. Contractor Delay to Completion is a delay which will cause a contract completion date not to be met.

6.1.17 Employer Risk Event

In case of employer is not able to furnish the full site and design documents as per the contract conditions then it shall be the employer's risk and event.

6.1.18 Employer Delay

The expression Employer Delay commonly describes any delay caused by an Employer Risk Event. An employer delay to completion will cause a contract completion date not to be met. However, Employer Delay to Progress is merely a delay to the Contractor's progress without impacting the contract completion date.

6.1.19 Concurrent delay

The expression concurrent delay, describes circumstances when a delay caused by Employer and a delay caused by Contractor, overlap during a period of time. It also describes circumstances when two delays, one caused by the Employer and another caused by the Contractor occur at different times, but their effects are felt (in whole or in part) at the same time.

6.1.20 Contemporaneous documents

Literal meaning of the word contemporaneous is concurrent i.e., that which is happening at the same time. Contemporaneous documents are records of activities that have happened or are happening at the same time as the event under consideration. These documents or records include as a minimum, work programme, updated immediately prior to the event, detailed short term look ahead programmes, records that explain the key considerations and assumptions regarding durations, key resources, risks, logic and sequences of activities in the programme, daily records of progress, daily report from site posted by site engineers, minutes of meetings, instructions, correspondence between the parties to the contract, letters, e-mails, all having relevance to the event under consideration.

6.1.21 Defect Liability period

- a) A Defect is any part of the Works not completed in accordance with the Contract.
- b) The Defects Liability Period is the period named in the Contract Data and calculated from the Completion Date.

6.1.22 Disruption

RFP for Development of three Child and Family-friendly junctions and 1.5km Connected shared Street at Saheli Marg and Big Bazar Rd, Udaipur, Rajasthan

Disruption is a disturbance, hindrance or interruption to a Contractor's normal working methods, resulting in lower efficiency. Disruption claims relate to loss of productivity in the execution of particular work activities.

6.1.23 Drawings

Good for Construction (GFC) drawing: These are the approved drawings issued by the Employer to the Contractor. The contractor executes the Works according to these drawings.

6.1.24 Tender Drawing

These are drawings issued by the Employer as part of the Request for Proposals (RFP) and are deemed sufficient for a bidder to quote for the project. The Bidder is expected to study these drawings and bring to the notice of the employer, any discrepancy/mistake at the tender stage itself.

6.1.25 Working Drawing

These are the drawings which are to be prepared by the Contractor showing details of construction, more elaborate than in the 'good for construction drawings' issued by the Employer. The Contractor takes the responsibility of the preparation and accuracy of the Working drawings.

6.1.26 As Built Drawings-

As Built drawings are the drawings of the finally executed works, generally developed from the working drawings, prepared by the Contractor and certified true by the Engineer/Supervision Consultant as authentic.

6.1.27 Earned Value

The Earned Value is the cumulative measure of the work performed expressed in monetary unit on any particular date.

6.1.28 The Employer

The Employer is the party named in the Contract Data who will employ the Contractor to carry out the Works.

6.1.29 The Engineer

The Engineer in-Charge or alternatively called the Engineer is the person or firm named in the Contract Data (or any other competent person appointed and notified to the contractor to act in replacement of the Engineer) who is responsible for supervising the Contractor's work, and administering the Contract.

6.1.30 The Equipment

The Equipment is the Contractor's machinery and vehicles brought temporarily to the Site to construct the Works.

6.1.31 Escrow account (Not Applicable)

6.1.32 Float

RFP for Development of three Child and Family-friendly junctions and 1.5km Connected shared Street at Saheli Marg and Big Bazar Rd, Udaipur, Rajasthan

The time available for an activity in addition to the planned duration. Free float is the amount of time an activity can be delayed beyond its early start/ early finish dates, without delaying the early start/early finish of any immediately following activity.

6.1.33 Initial contract Price

The Initial Contract Price is the Contract Price listed in the Employer's Letter of Award.

6.1.34 Materials

Materials are all supplies, including consumables, used by the contractor for incorporation in the Works.

6.1.35 Method statement

A written description of the Contractor's proposed manner of safely carrying out the Works or part thereof, setting out assumptions underlying the chosen method and the reasoning behind the approach to the various phases of construction. It should include details of key resources, including men material and machinery.

6.1.36 Planned Value

Planned value is the planned future expenditure for a period, i.e., for a month, a financial quarter, a year or the period or the total contract period.

6.1.37 Plant

Plant is any integral part of the Works, which is to have a mechanical, electrical, electronic or chemical or biological function.

6.1.38 The Routine Maintenance Works

The Routine Maintenance Works means the works required to be carried out by the Contractor between the commencement date and the date on which Taking over Certificate is issued to keep the site in traffic- worthy condition for movement of usual traffic as well as construction traffic. Routine Maintenance Works form part of works but are considered incidental to the works and are not separately paid for.

6.1.39 The Site

The Site is the area defined as such in the Contract data.

6.1.40 Site Investigation Reports

Site Investigation Reports are those, which were included in the Bidding documents and are actual interpretative reports about the surface and sub-surface conditions at the site.

6.1.41 Specifications

The Specification means the description of scope of work, materials to be used, methods of installation/ construction, quality of workmanship expected by the Employer in any element of work included in the Contract and any modification or addition made or approved by the Employer.

RFP for Development of three Child and Family-friendly junctions and 1.5km Connected shared Street at Saheli Marg and Big Bazar Rd, Udaipur, Rajasthan

6.1.42 The Start Date/ Commencement Date

The Start Date/Date of Commencement is that given in the Contract Data, when contract agreement is signed. It does not necessarily coincide with any of the Site Possession Dates.

6.1.43 Variation

A Variation is an instruction given by the Engineer, which changes the scope of the Works both in respect of increase or decrease of quantities, specifications and execution of new items.

6.1.44 The Works

The Works are what the Contract requires the Contractor to construct, install, and hand over to the Employer, as defined in Scope of Works.

6.1.45 Temporary Works

Temporary Works are works designed, constructed, installed, and removed by the Contractor, which are needed for construction or installation of the permanent Works.

RFP for Development of three Child and Family-friendly junctions and 1.5km Connected shared Street at Saheli Marg and Big Bazar Rd, Udaipur, Rajasthan

6.2 INTERPRETATION

6.2.1 In interpreting these Conditions of Contract, singular also means plural, male also means female or neuter and the other way around. Headings have no significance. The marginal words and other headings shall not be taken into consideration in the interpretation of these Conditions. In this Contract, except where the context requires otherwise.

- a) Works have their normal meaning under the language of the Contract unless specifically defined. The Engineer-in-charge will provide instructions clarifying queries about the Conditions of the Contract;
- b) words indicating the singular also include the plural and words indicating the plural also include the singular;
- c) provisions including the word "agree", "agreed" or "agreement" require the agreement to be
- d) Recorded in writing;
- e) "written" or "in writing" means hand-written, type-written, printed or electronically made, and resulting in a permanent record;
- f) The word "tender" is synonymous with "bid" and "tenderer" with "bidder" and the words "tender document" with "bidding document".

6.2.2 The Implementing Agency may complete the work in sections as per the approved work program and in such case, references in the Conditions of Contract to the Works, the Completion Date and the Intended Completion Date shall apply to such section of the Works (other than references to the Completion Date and Intended Completion date for the whole of the Works).

6.2.3 The documents forming the Contract shall be interpreted in the following order of priority:

- a) Agreement
- b) Letter of Award, notice to proceed with the works
- c) Contract Data
- d) Conditions of Contract including Special or Particular Conditions of Contract
- e) Specifications
- f) Drawings
- g) Summary/ Quantity Schedule
- h) Contractor's Bid
- i) Any other Document (specified in the Contract Data)

6.3 Language and Law

The language of the Contract and the law governing the Contract are as stated in the Contract Data.

6.4 Engineer's Duties and Authority

6.4.1 The employer shall appoint the Engineer who shall carry out the duties assigned to him

RFP for Development of three Child and Family-friendly junctions and 1.5km Connected shared Street at Saheli Marg and Big Bazar Rd, Udaipur, Rajasthan

in the Contract. The Engineer's staff shall include suitably qualified engineers and other professionals who are competent to carry out these duties. The Engineer shall have no authority to amend the Contract.

- 6.4.2** Except otherwise specifically stated in the Contract Data, the Engineer will represent the Employer, protect the interests of the Employer and decide contractual matters between the Employer and the Contractor, as per the provisions of the contract. Engineer's decisions will be impartial.
- 6.4.3** The Engineer may exercise the authority attributable to the Engineer as specified in or necessarily to be implied from the Contract. If the Engineer is required to obtain the approval of the Employer before exercising a specified authority, the requirements shall be as stated in the Particular Conditions. The Employer shall promptly inform the Contractor of any change to the authority attributed to the Engineer. However, whenever the Engineer exercises a specified authority for which the Employer's approval is required, then (for the purposes of the Contract) the Employer shall be deemed to have given approval.
- 6.4.4** The Engineer has no authority to relieve either Party of any duties, obligations or responsibilities under the Contract; any approval, check, certificate, consent, examination, inspection, instruction, notice, proposal, request, test, or similar act by the Engineer (including absence of disapproval) shall not relieve the Contractor from any responsibility he has under the Contract, including responsibility for errors, omissions, discrepancies and non-compliances; and any act by the Engineer in response to a Contractor's request except as otherwise expressly specified shall be notified in writing to the Contractor within 28 days of receipt.
- 6.4.5** The Engineer shall obtain the specific approval of the Employer before taking action under the following
- a) Agreeing or determining an extension of time and/or additional cost.
 - b) instructing a Variation, except;
 - i. in an emergency situation as determined by the Engineer, or
 - ii. if such a Variation would increase the Accepted Contract Amount by less than the percentage specified in the Contract Data.

Notwithstanding the obligation, as set out above, to obtain approval, if, in the opinion of the Engineer, an emergency occurs affecting the safety of life or of the Works or of adjoining property, he may, without relieving the Contractor of any of his duties and responsibility under the Contract, instruct the Contractor to execute all such work or to do all such things as may, in the opinion of the Engineer, be necessary to abate or reduce the risk. The Contractor shall forthwith comply, despite the absence of approval of the Employer, with any such instruction of the Engineer. The Engineer shall determine an addition to the Contract Price, in respect of such instruction, and shall notify the Contractor accordingly, with a copy to the Employer.

6.4.6 Delegation by the Engineer:

The Engineer may from time to time assign duties and delegate authority to assistants, and

RFP for Development of three Child and Family-friendly junctions and 1.5km Connected shared Street at Saheli Marg and Big Bazar Rd, Udaipur, Rajasthan

may also revoke such assignment or delegation. These assistants may include a resident engineer, and/or independent inspectors appointed to inspect and/or test items of Plant and/or Materials. The assignment, delegation or revocation shall be in writing and shall not take effect until copies have been received by both Parties.

Assistants shall be suitably qualified persons, who are competent to carry out these duties and exercise this authority, and who are fluent in the language for communications defined in this Contract.

Each assistant, to whom duties have been assigned or authority has been delegated, shall only be authorised to issue instructions to the Contractor to the extent defined by the delegation. Any approval, check, certificate, consent, examination, inspection, instruction, notice, proposal, request, test, or similar act by an assistant, in accordance with the delegation, shall have the same effect as though the act had been an act of the Engineer. However:

- a) any failure to disapprove any work, Plant or Materials shall not constitute approval, and shall therefore not prejudice the right of the Engineer to reject the work, Plant or Materials;
- b) if the Contractor questions any determination or instruction of an assistant, the Contractor may refer the matter to the Engineer, who shall promptly confirm, reverse or vary the determination or instruction.

6.4.7 Instructions of the Engineer

The Engineer may issue to the Contractor (at any time) instructions and additional or modified Drawings which may be necessary for the execution of the Works and the remedying of any defects, all in accordance with the Contract. The Contractor shall only take instructions from the Engineer, or from an assistant to whom the appropriate authority has been delegated under this Clause. If an instruction constitutes a Variation, Clause 6.25.3 [Variations] shall apply. The Contractor shall comply with the instructions given by the Engineer or a delegated assistant. If the Engineer or a delegated assistant (a) gives an oral instruction, (b) receives a written confirmation of the instruction, from (or on behalf of) the Contractor, within two working days after giving the instruction, and (c) does not reply by issuing a written rejection and/or instruction within two working days after receiving the confirmation, then the confirmation shall constitute the written instruction of the Engineer or delegated assistant (as the case may be).

6.5 Communications

Communications between parties which are referred to in the conditions are effective only when in writing. A notice shall be effective only when it is delivered (in terms of Indian Contract Act).

6.6 Sub-contracting

6.6.1 The Contractor may sub-contract any portion of work, up to a limit specified in Contract Data, with the approval of the Engineer but shall not assign such portion of the Contract without the approval of the Employer in writing.

RFP for Development of three Child and Family-friendly junctions and 1.5km Connected shared Street at Saheli Marg and Big Bazar Rd, Udaipur, Rajasthan

The Contractor shall not subcontract the whole of the works. Unless otherwise stated in the Particular Conditions:

- a) the Contractor shall not be required to obtain consent to suppliers solely of Materials, or to a subcontract for which the Subcontractor is named in the Contract;
- b) the prior consent of the Engineer shall be obtained to other proposed Subcontractors;
- c) the Contractor shall give the Engineer not less than 28 days' notice of the intended date of the Commencement of each Subcontractor's work, and of the commencement of such work on the Site; and
- d) each subcontract shall include provisions which would entitle the Employer to require the subcontractor to be assigned to the Employer under Sub-Clause

6.6.2 [Assignment of Benefit of Subcontract] (if or when applicable) or in the event of termination under Clause 6.26.5 [Termination by Employer].

6.6.3 Assignment of Benefit of Subcontract If a Subcontractor's obligations extend beyond the expiry date of the relevant Defects Notification Period and the Engineer, prior to this date, instructs the Contractor to assign the benefit of such obligations to the Employer, then the Contractor shall do so. Unless otherwise stated in the assignment, the Contractor shall have no liability to the Employer for the work carried out by the Subcontractor after the assignment takes effect.

6.6.4 If the contractor, beyond the above limit, proposes sub-contracting any part of the work during execution of works, because of some unforeseen circumstances to enable him to complete the work as per terms of the contract, the Engineer may consider the same for according approval.

6.6.5 The contractor shall sub-contract for executing the specialized work portion only.

6.6.6 Consent of the Engineer for sub-contracting shall not relieve the contractor from any liability or obligations under the contract and he shall be responsible for the acts, defaults and neglects of any sub-contractor, his agents or workmen as fully as if they were the acts, defaults or neglects of the contractor, his agents or workmen.

6.6.7 The Contractor should justify in the proposal for sub-contracting, whether (a) the circumstances warrant such sub- contracting; and (b) the sub-contractors so proposed for the work possess the experience, qualification, equipment and necessary license, if any, required for the job proposed to be entrusted to them in proportion to the quantum of work to be sub-contracted. The Engineer shall, if necessary, verify the documents so submitted prior to approving the proposal for subcontracting.

6.6.8 If payments are proposed to be made directly to that sub-contractor, this should be subject to specific authorization by the prime contractor. Any such arrangement does not alter the prime contractor's liability or obligations under the contract.

6.6.9 Before issuing a Payment Certificate to the Contractor, which includes an amount payable to a subcontractor, the Engineer / Employer may request the Contractor to supply reasonable evidence that the subcontractor has received all amounts due in

**RFP for Development of three Child and Family-friendly junctions and 1.5km
Connected shared Street at Saheli Marg and Big Bazar Rd, Udaipur, Rajasthan**

accordance with previous Payment Certificates, less applicable deductions for retention or otherwise.

RFP for Development of three Child and Family-friendly junctions and 1.5km Connected shared Street at Saheli Marg and Big Bazar Rd, Udaipur, Rajasthan

6.7 NOMINATED SUBCONTRACTORS

6.7.1 Definition of “nominated Subcontractor” In the Contract, “nominated Subcontractor” means a Subcontractor:

- a) who is stated in the Contract as being a nominated Subcontractor,
- b) whom the Engineer, under Clause 6.25.3 [Variations and Adjustments], instructs the Contractor to employ as a Subcontractor

6.7.2 Objection to Nomination

The Contractor shall not be under any obligation to employ a nominated Subcontractor against whom the Contractor raises reasonable objection by notice to the Engineer as soon as practicable, with supporting particulars. An objection shall be deemed reasonable if it arises from (among other things) any of the following matters, unless the Employer agrees in writing to indemnify the Contractor against and from the consequences of the matter:

- a) there are reasons to believe that the Subcontractor does not have sufficient competence, resources or financial strength;
- b) the nominated Subcontractor does not accept to indemnify the Contractor against and from any negligence or misuse of Goods by the nominated Subcontractor, his agents and employees; or
- c) the nominated Subcontractor does not accept to enter into a subcontract which specifies that, for the subcontracted work (including design, if any), the nominated Subcontractor shall:
 - i. undertake to the Contractor such obligations and liabilities as will enable the Contractor to discharge his obligations and liabilities under the Contract,
 - ii. indemnify the Contractor against and from all obligations and liabilities arising under or in connection with the Contract and from the consequences of any failure by the Subcontractor to perform these obligations or to fulfil these liabilities, and
 - iii. be paid only if and when the Contractor has received from the Employer payments for sums due under the Subcontract referred to under Clause 6.7.3 [Payment to nominated Subcontractors].

6.7.3 Payments to nominated Subcontractors

The Contractor shall pay to the nominated Subcontractor the amounts shown on the nominated Subcontractor's invoices approved by the Contractor which the Engineer certifies to be due in accordance with the subcontract.

6.7.4 Evidence of Payments

Before issuing a payment certificate which includes an amount payable to a nominated Subcontractor, the Engineer may request the Contractor to supply reasonable evidence that the nominated Subcontractor has received all amounts due in accordance with previous Payment Certificates, less applicable deductions for retention or otherwise. Unless the Contractor:

- a) submits this reasonable evidence to the Engineer, or
 - b) satisfies the Engineer in writing that the Contractor is reasonably entitled to withhold or
-

RFP for Development of three Child and Family-friendly junctions and 1.5km Connected shared Street at Saheli Marg and Big Bazar Rd, Udaipur, Rajasthan

refuse to pay these amounts, and submits to the Engineer reasonable evidence that the nominated Subcontractor has been notified of the Contractor's entitlement, then the Employer may (at his sole discretion) pay, direct to the nominated Subcontractor,

- c) Part or all of such amounts previously certified (less applicable deductions) as are due to the nominated Subcontractor and for which the Contractor has failed to submit the evidence described in sub-paragraphs (a) or (b) above. The Contractor shall then repay, to the Employer, the amount which the nominated Subcontractor was directly paid by the Employer.

6.8 Other Contractors

The Contractor shall cooperate and share the Site with other contractors, public authorities, Line Departments and the Employer on the dates as notified by the Employer from time to time. The Employer may modify these dates and shall notify the contractor of any such modification.

6.9 Personnel

6.9.1 The Contractor shall employ the key personnel named in the Schedule of Key Personnel as referred to in the Contract Data to carry out the functions stated in the Schedule or other personnel approved by the Engineer.

6.9.2 The Engineer will approve any proposed replacement of key personnel only if qualifications, abilities, and relevant experience are substantially equal to or better than those of the personnel listed in the Schedule.

6.9.3 If the Engineer asks the Contractor to remove a person who is a member of the Contractor's staff or his work force stating the reasons the Contractor shall ensure that the person leaves the Site within seven days and has no further connection with the work in the Contract

6.9.4 Except as otherwise stated in the Specification, the contractor shall make arrangements for the engagement of all staff and labour, local or otherwise, and for their payment, feeding, transport and when appropriate, housing. The contractor is encouraged to the extent practicable and reasonable, to employ staff and labour with appropriate qualifications and experience from sources within the State of Rajasthan.

6.10 Risks

The Employer carries the risks which this Contract states are Employer's risks, and the Contractor carries the risks which this Contract states are Contractor's risks.

6.10.1 Employer's Risks

The Employer is responsible for the expected risks which are: -

- a) in so far as they directly affect the execution of the works in the State of Rajasthan, the risks of war, hostilities, invasion, act of foreign enemies, rebellion, revolution, insurrection or military or usurped power, civil war, riot commotion or disorder (unless restricted to the Contractor's personnel), and contamination from any nuclear fuel or nuclear waste or radioactive toxic explosive,
-

RFP for Development of three Child and Family-friendly junctions and 1.5km Connected shared Street at Saheli Marg and Big Bazar Rd, Udaipur, Rajasthan

- b) use or occupation by the Employer of any part of the Permanent Works, except as may be specified in the Contract,
- c) a cause solely due to the design of the works, other than the Contractor's design, or
- d) Any operation of the forces of nature which is unforeseeable or against which an experienced contractor could not reasonably have been expected to have taken adequate preventative precautions.
- e) Removal of underground utilities detected subsequently.
- f) Significant change in classification of soil requiring additional mobilisation by the contractor, e.g., ordinary soil to rock excavation
- g) Removal of unsuitable material like marsh, debris dumps, etc. not caused by the contractor.
- h) Artesian conditions.
- i) Seepage, erosion, landslide.
- j) Presence of historical, archaeological or religious structures, monuments interfering with the works.
- k) Restriction of access to ground imposed by civil, judicial or military authority.

6.10.2 Rectification costs due to damage of works on account of Employer's risks – If the works are damaged due to Employer's risk as per Clause 6.10.1, a committee consisting of the Employer's representative, Engineer's representative and Contractor's representative will carry out a detailed inspection of damaged works and prepare a detailed report of damages occurred. The Committee shall prepare detailed cost estimate as per agreed payment schedule or BoQ rates of the works. A variation order shall be prepared for rectification of the damaged works giving the time frame for completion of the rectification. The cost of rectification shall be paid to the Contractor through interim payment certificate.

6.10.3 Contractor's Risks

The Contractor shall take full responsibility for the care of the Works and Goods from the Commencement Date until the Taking-over Certificate is issued (Taking-over of the Works and Sections) for the Works, when responsibility for the care of the Works shall pass to the Employer. The Contractor is also responsible for the risks stated below: a. damage to or loss of any property, real or personal (other than the Works), to the extent that such damage or loss arises out of or in the course of or by reason of the Contractor's design (if any), the execution and completion of the Works and the remedying of any defects; b. personal injury including deaths which arise during and in consequence of the performance of the Contract; all other risks other than the excepted risks stated in Clause 6.10.2

6.11 Insurance

6.11.1 The Contractor shall provide, in the joint names of the Employer and the Contractor, insurance covers in two parts, i.e. (a) from the start date to the completion date, and (b) for the Defect Liability period, in the amounts stated in the Contract Data for the following events which are due to the Contractor's risks:

- a) loss of or damage to the Works, Plants and Materials;
 - b) loss of or damage to Equipment;
-

RFP for Development of three Child and Family-friendly junctions and 1.5km Connected shared Street at Saheli Marg and Big Bazar Rd, Udaipur, Rajasthan

- c) loss of or damage of property (except the Works, Plant, Materials and Equipment) in connection with the Contract;
- d) Workman compensation policy to cover personal injury or death.

6.11.2 Policies and Certificates for insurance shall be delivered by the Contractor to the Engineer's approval before the Start Date. All such insurance shall provide for compensation to be payable in the types and proportions of currencies required to rectify the loss or damage incurred.

6.11.3 Alterations to the terms of insurance shall not be made without the approval of the Employer.

6.11.4 Both parties shall comply with any conditions of the insurance policies.

6.12 Site Investigation Reports

6.12.1 The UMC shall make or arrange to make available (on best effort basis only) to the Contractor for his information all relevant data in the UMC or any other government agency's possession regarding the sub-surface and soil conditions at the Site, including environmental aspects. The Contractor shall be responsible for verifying and interpreting all such data. The UMC or any other agency providing the data shall not be held responsible about the correctness of all such data and the Contractor shall confirm/ verify all such data at his own cost.

6.12.2 To the extent which was practicable taking account of Cost and time, the Contractor shall be deemed to have obtained all necessary information as to risks, contingencies and other circumstances which lay influence or affect the Bid for Works. To the same extent, the Contractor shall be deemed to have inspected and examined the Site, its surroundings, the above data and other available information, and to have been satisfied before submitting the Bid as to all relevant matters, including without limitation.

6.13 Queries about the Contract Data

6.13.1 The Engineer-in-Charge will clarify queries if any on the Contract Data.

6.14 Contractor to Construct the Works

6.14.1 Commencement of the Works

The Contractor shall commence execution of the Works on the Start Date and shall carry out the Works in accordance with the programme submitted by the Contractor, as updated with the approval of the Engineer I/C.

6.14.2 Construction of the Works

The Contractor shall construct and install the Works in accordance with the approved Specifications and Drawings, and as per instructions of the Engineer. During continuance of the contract, the Contractor and his sub- contractors shall abide at all times by all existing labour enactments and rules, as mentioned in the Particular Conditions of Contract.

6.14.3 Protection of the environment

RFP for Development of three Child and Family-friendly junctions and 1.5km Connected shared Street at Saheli Marg and Big Bazar Rd, Udaipur, Rajasthan

The Contractor shall take all reasonable steps to protect the environment on and off the Site and to avoid damage or nuisance to persons or to property of the public or other resulting from pollution, noise or other causes arising as a consequence of his methods of operation. During continuance of the contract, the Contractor and his sub-contractors shall abide at all times by all existing enactments on environmental protection and rules made there under, regulations, notifications and bye-laws of the State or Central Government, or local authorities and any other law, by-law, regulations that may be passed or notification that may be issued in this respect in future by the State or Central Government or the local authority. Salient features of some of the major laws that are applicable are provided in the Special Conditions of Contract

6.14.4 Non-performance of the routine maintenance works by the Contractor – In the event that the Contractor fails to carryout routine maintenance works as directed by Engineer's representative within the reasonable time, it shall be deemed as a failure of the obligation by the Contractor. The Employer shall without prejudice to its rights under the Contract including termination thereof, be entitled to undertake such maintenance works at the cost of the Contractor. The cost incurred by the Employer will be recovered from the Contractor through deduction from the interim payment certification of the Contractor.

6.15 Completion of the Works

The Contractor shall complete the Works by the intended date of completion. In case Extension of Time has been granted, the extended date of completion shall be considered.

6.16 Approval by the Engineer

6.16.1 The Contractor shall get vetted from any IIT/NIT, the design and drawings of the Foundation and Structures as per scope of work at his own cost and shall submit Specifications and Drawings showing the proposed Temporary Works to the Engineer, who is to approve them if they comply with the Specifications and Drawings.

6.16.2 The Contractor shall be responsible for design and safety of Temporary and Permanent Works.

6.16.3 The Engineer's approval shall not alter the Contractor's responsibility for design and safety of the Temporary Works.

6.16.4 All Drawings prepared by the Contractor for the execution of the Temporary or Permanent Works, are subject to prior approval by the Engineer before their use.

6.17 Safety

The Contractor shall be responsible for the safety of all the personnel, plant and equipment deployed by him in the Work-related activities and the Works on the Site, even if the method of construction has been shared by the Contractor with the Employer or the Engineer.

6.18 Discoveries

Anything of historical or other interest or of significant value unexpectedly discovered on the Site is the property of the Employer. The Contractor is to notify the Engineer of such discoveries and carry out the Engineer's instructions for dealing with them.

RFP for Development of three Child and Family-friendly junctions and 1.5km Connected shared Street at Saheli Marg and Big Bazar Rd, Udaipur, Rajasthan

6.19 Possession of the Site

The Employer shall give the Contractor right of access to, and possession of, all parts of the Site within the time (or times) stated in the Contract Data. If possession of a part of the site is not given by the date stated in the Contract Data, the Employer shall give suitable extension of time for completion of work. The Employer shall not pay any compensation on this account except price adjustment as per clause 6.25.13.

6.20 Access to the Site

The Contractor shall allow the Employer and any person authorized by the Employer access to the Site, to any place where work in connection with the Contract is being carried out or is intended to be carried out and to any place where materials or plant are being manufactured/ fabricated/assembled for the works.

6.21 Instructions

6.21.1 The Contractor shall carry out all instructions of the Engineer pertaining to works, which comply with the applicable laws where the Site is located.

6.21.2 The Contractor shall permit the Employer or his authorized representative to inspect the Contractor's accounts and records relating to the performance of the Contractor and to have them audited by auditors appointed by the Employer, if so, required by the Employer.

6.22 Disputes Resolution Mechanism

- a) If any dispute or differences of any kind what-so-ever arise between the UMC, its authorized representatives and the Contractor in connection with or arising out of this Contract or the execution of Work, it will be first attempted to be resolved amicably in accordance with the conciliation procedure set forth below
 - b) Whether before its commencement or during the progress of Project/ Works or after the termination, abandonment or breach of the Contract, the dispute shall in the first instance supported with complete documents and further documents, if any, required by the other party, be referred for settlement to the Engineer-in-charge of the Work and he shall, within a period of thirty (30) days after being requested in writing by either party mediate and convey his decision.
 - c) If the Engineer-in-charge/Conciliator has conveyed his decision and no claim for arbitration has been filed by either party within a period of thirty (30) days from the receipt of the letter communicating the decision, the said decision shall be final and binding upon the party and will not be a subject matter of arbitration at all.
 - d) If the meditation/conciliation fails, either party may require such Dispute to be referred to the UMC Board and the Chairman or chief Executive of the Contractor for amicable settlement; Such persons shall meet within 7 days of the Dispute being referred to them. If the dispute is not amicably settled within 30(thirty) days of the matter being referred to the above persons, either party may refer the Dispute to arbitration.
 - e) All disputes or differences in respect of which the decision is not final and conclusive shall, at the request of either party made in communication sent through registered A.D. post, be referred for arbitration by the Arbitral Tribunal consisting of the sole Arbitrator to be nominated by the Commissioner, UMC.
-

RFP for Development of three Child and Family-friendly junctions and 1.5km Connected shared Street at Saheli Marg and Big Bazar Rd, Udaipur, Rajasthan

- f) The reference to the Arbitral Tribunal shall be made by the claimant party within one hundred twenty (120) days from the date of dispute of claim arises during the execution of Work. If the claim pertains to rates or recoveries introduced in the final bill, the reference to the Arbitral Tribunal shall be made within six (6) calendar months from the date of payment of the final bill to the Contractor or from the date a registered notice is sent to the Contractor to the effect that his final bill is ready by the Engineer in- charge (whose decision in this respect shall be final and binding) whichever is earlier.
- g) The provisions of the Arbitration and Reconciliation Act, 1996 or any other statutory law there under or modification thereof and for the time being in force shall apply to the arbitration proceedings under this clause.
- h) The Arbitrator/Arbitral Tribunal shall give a reasoned award for each claim/counter claim.
- i) The independent claims of the party other than one seeking arbitration as also the counter claims of any party shall be entertained by the arbitrator.
- j) The venue of arbitration shall be Udaipur, Rajasthan. The work under the contract shall continue during the arbitration proceedings.
- k) The stamp fee due on the award shall be payable by the party as desired by the Arbitral Tribunal and in the event of such party's default, the stamp fee shall be recoverable from another sum due to such party under this or any other contract.
- l) Neither party shall be entitled to bring a claim for arbitration, if it is not filed as per the time period already specified or within six (6) months of the following: -
- i. of the date of completion of the Work as certified by the Engineer-in-charge or
 - ii. of the date of abandonment of the Work or breach of Contract under any of its clauses, or
 - iii. of its non-commencement or non-resumption of Work within ten (10) days of written notice for commencement or resumption as applicable, or
 - iv. of the cancellation, termination or withdrawal of the work from the Contractor in whole or in part and/or revision for closure of the Contract, or
 - v. of receiving an intimation from the Engineer-in-charge that the final payment due or to be recovered from the Contractor had been determined, for the purpose of payment/adjustment whichever is the latest. If the matter is not referred to arbitration within the period prescribed above, all the rights and claims of either party under the contract shall be deemed to have been forfeited and absolutely barred by the time for arbitration and even for civil litigation.
- m) No question relating to this Contract shall be brought before any civil court without first invoking and completing the arbitration proceedings, if the issue is covered by the scope of arbitration under the Contract. The pending arbitration proceedings shall not disentitle the Engineer-in- charge to terminate the Contract and to make alternate arrangement for completion of the Works.
- n) Arbitral Tribunal shall be deemed to have entered into the reference on the day, notice is issued to the parties fixing the first date of hearing. The Arbitrator/Arbitral Tribunal may, from time to time, with the consent of the parties enlarge the initial time for making and publishing the award. However, the Arbitrator/Arbitral Tribunal shall make all out efforts to decide each claim within a period of six (6) months from the date of initiation.
-

**RFP for Development of three Child and Family-friendly junctions and 1.5km
Connected shared Street at Saheli Marg and Big Bazar Rd, Udaipur, Rajasthan**

- o) The expiry to the contractual time limit, whether originally fixed or extended, shall not invalidate the provisions of this clause.

RFP for Development of three Child and Family-friendly junctions and 1.5km Connected shared Street at Saheli Marg and Big Bazar Rd, Udaipur, Rajasthan

6.23 TIME CONTROL

6.23.1 Programme

6.23.2 Within 14 days of issue of letter of award of work, the successful bidder shall submit to the Employer detailed resource-based work programme. The Programme shall clearly show an appropriate Work breakdown structure, the time required to complete each element of work and the interrelationship of elements by defining a critical path- It will show the resources, men material and plant, required to carry out each element of work. The Work programme shall include Environmental Management Plan for approval showing the general methods, arrangements, order and timing for all the activities in the Works along with quarterly planned value statement.

6.23.3 An update of the Program shall be a program showing the actual progress achieved on each activity, the earned value and the effect of the progress achieved on the timing of the remaining work including any changes to the sequence of the activities.

6.23.4 The contractor shall submit to the Engineer, for approval, an updated Program at intervals no longer than the period of 30 days. If the Contractor does not submit an updated Program within this period, the Engineer may withhold the amount as specified in the Contract Data and continue to withhold this amount until the next payment after the date on which the overdue program has been submitted.

6.23.5 The Engineer's approval of the Program shall not alter the Contractor's obligations. The Contractor may revise the Program and submit it to the Engineer again at any time. A revised Program shall show the effect of Variations and Compensation Events.

6.23.6 The program will be supported with all the details regarding key personnel, equipment and machinery proposed to be deployed on the works for its execution. The contractor shall submit the list of equipment and machinery being brought to site, the list of key personnel being deployed, the list of machinery/equipment being placed in the field laboratory, if any set up by the Contractor.

6.23.7 Extension of the Intended Completion Date

6.23.8 If the Contractor shall desire an extension of time for completion of work on the ground, he shall apply in writing to the Engineer-in -charge within 15 days of the occurrences of such event. The Employer shall extend the Intended Completion Date if a Compensation Event occurs or a Variation is issued which makes it impossible for Completion to be achieved by the intended Completion Date without the Contractor taking steps to accelerate the remaining work and which would cause the Contractor to incur additional cost.

6.23.9 The Employer shall decide whether and by how much to extend the Intended Completion Date within 28 days of the Contractor asking the Engineer for a decision upon the effect of a Compensation Event or Variation and submitting full supporting information. If the Contractor has failed to give early warning of a delay or has failed to cooperate in dealing with a delay, the delay by this failure shall not be considered in assessing the new Intended Completion Date.

6.23.10 The Engineer shall, within 14 days of receiving full justification from the contractor for

RFP for Development of three Child and Family-friendly junctions and 1.5km Connected shared Street at Saheli Marg and Big Bazar Rd, Udaipur, Rajasthan

extension of Intended Completion Date, refer to the Employer his recommendation. The Employer shall in not more than 14 days communicate to the Engineer the Employer's decision. If the Employer fails to give his ward, the Engineer shall not grant the extension of time and the Contractor may refer the matter to the Arbitration under Clause 6.27.8 of P.C.C.

6.23.11 Delays Ordered by the Engineer

6.23.11.1 The Engineer may instruct the Contractor to delay the start or progress of any activity within the Works.

6.23.12 Management Meetings

6.23.13 Either the Engineer or the Contractor may require the other to attend a management meeting. The business of a management meeting shall be to review the plans for remaining work and to deal with matters raised in accordance with the early warning procedure.

6.23.14 The Engineer shall record the business of management meetings and is to provide copies of his record to those attending the meeting and to the Employer. The responsibility of the parties for actions to be taken is to be decided by the Engineer either at the management meeting or after the management meeting and stated in writing to all who attended the meeting.

6.23.15 Progress Reports: The Contractor shall prepare and submit the monthly progress reports to the Engineer in two hard copies including soft copy. The first report shall cover the period up to the end of the first calendar month following the Commencement Date. Reports shall be submitted monthly thereafter, each within 7 days after the last day of the period to which it relates. Reporting shall continue until the Contractor has completed all work which is known to be outstanding at the completion date stated in the Taking-over Certificate for the Works.

Each report shall include:

- a) charts and detailed descriptions of progress, including each stage of design (if any), Contractor's Documents, procurement, manufacture, delivery to Site, construction, erection and testing;
 - b) photographs showing the status of progress of work on the Site;
 - c) Status of mobilization of Contractor's Personnel and Equipment;
 - d) Copies of quality assurance documents, test results and certificates of Materials;
 - e) List of early warning notices issued to the Engineer under Clause 6.23.16
 - f) Safety statistics, including details of any hazardous incidents and activities relating to environmental aspects and public relations; and
 - g) Comparisons of actual and planned progress, with details of any events or circumstances which may jeopardize the completion in accordance with the Contract, and the measures being (or to be) adopted to overcome delays.
 - h) Subcontractors appointed by the contractor, including the tasks assigned to them, and their outputs in the month of reporting.
 - i) Report on risks identified including their possible impact on time, cost and quality and the
-

RFP for Development of three Child and Family-friendly junctions and 1.5km Connected shared Street at Saheli Marg and Big Bazar Rd, Udaipur, Rajasthan

j) Contractor's proposals for mitigation of the risks.

6.23.16 Early Warning

6.23.16.1 The Contractor is to warn the Engineer at the earliest opportunity of specific likely future events or circumstances that may adversely affect the work resulting delay in the execution. The Engineer may require the Contractor to provide an estimate of the expected effect of the future event or circumstance on the Completion Date. The estimate shall be prepared by the Contractor as soon as possible (not later than 28 days of becoming aware of the event) and submitted to the Engineer.

6.23.16.2 The Contractor shall cooperate with the Engineer in making and considering proposals for how the effect of such an event or circumstance can be avoided or reduced by anyone involved in the work and in carrying out any resulting instruction of the Engineer.

6.23.16.3 Failure by the contractor to intimate and warn the Engineer about such events or circumstances shall forfeit the claim of the Contractor for time or cost compensation.

RFP for Development of three Child and Family-friendly junctions and 1.5km Connected shared Street at Saheli Marg and Big Bazar Rd, Udaipur, Rajasthan

6.24 QUALITY CONTROL

6.24.1 Quality Aspects

6.24.2 The Contractor shall be carrying out mandatory tests as prescribed in the specifications or otherwise required as per Good Industry Practice. The contractor shall establish the field laboratory at site and incase the facility for conducting any particular test is not available in the field laboratory then the same shall be got tested from a NABL accredited laboratory. The Contractor shall consider the cost of tests required as per Good Industry Practice while bidding for this document. The Contractor shall be solely responsible for:

6.24.3 Carrying out and bearing the cost of the mandatory tests prescribed in the Specifications or recommended by Engineer-in-Charge; and

6.24.4 For the correctness of the test results, whether performed in his laboratory or elsewhere.

6.24.5 The Engineer-in-charge will be free to conduct surprise, random or in situ checks any time during the execution and after the completion of the Work but not later than the Operation & Maintenance Period, so as to have cross check in quality of works carried out and compliance to specifications and standards at all stages of the Work.

6.24.6 Nothing in this clause shall reduce the overall responsibility of the Contractor regarding quality and he shall remain liable for any defect in the execution of the Project/Works at all stages.

6.24.7 Identifying Defects

6.24.8 The Engineer shall check the Contractor's work and notify the Contractor of any Defects that are found. Such checking shall not affect the Contractor's responsibilities. The Engineer may instruct the Contractor to search for a Defect and to uncover and test any work that the Engineer considers may have a Defect.

6.24.9 The Contractor shall permit the Employer's Technical auditor to check the Contractor's work and notify the Engineer and Contractor of any defects that are found. Such a check shall not affect the Contractor's or the Engineer's responsibility as defined in the Contract Agreement.

6.24.10 Tests

6.24.10.1 If the Engineer instructs the Contractor to carry out a test not specified in the Specification to check whether any work has a Defect and the test shows that it does, the Contractor shall pay for the test and any samples. If there is no Defect the test shall be a Compensation Event.

6.24.11 Correction of Defects

6.24.12 The Engineer shall give notice to the Contractor of any Defects before the end of the Defects Liability Period, which begins at Completion and is defined in the Contract Data. The Defects Liability Period shall be extended for as long as Defects remain to be corrected.

RFP for Development of three Child and Family-friendly junctions and 1.5km Connected shared Street at Saheli Marg and Big Bazar Rd, Udaipur, Rajasthan

6.24.13 Every time notice of a Defect is given, the Contractor shall correct the notified Defect within the length of time specified by the Engineer's notice.

6.24.14 The contractor shall be responsible for rectification of all defects that may occur during Defect Liability Period.

6.24.15 Defects

6.24.15.1 If the Contractor has not corrected a Defect within the time specified in the Engineer's notice, the Engineer will assess the cost of having the Defect corrected, and recover 1.5 times of this amount from the payments due to the Contractor or from retention money.

6.24.15.2 Where in certain cases, the technical specifications provide for acceptance of works within specified tolerance limits at reduced rates, Engineer will certify payments to Contractor accordingly.

6.24.16 Issuance of Certificate of Construction Completion

6.24.16.1 Upon being satisfied that the quality work has been executed by the Contractor in accordance with the Conditions of Contract, Scope of Work & Specifications, UMC's requirements, Drawings, etc., and also upon the Tests having been conducted successfully the Engineer-in-charge shall issue a Certificate of Development Completion signifying completion of construction of Works and commencement of Defects Liability Period and Operation & Maintenance Period. However, no certificate shall be issued nor shall the work be considered to be complete until the Contractor has cleared all scaffolding, surplus materials, garbage and all huts and sanitary arrangements set up for the labour at the site and cleaned off the dirt from work.

RFP for Development of three Child and Family-friendly junctions and 1.5km Connected shared Street at Saheli Marg and Big Bazar Rd, Udaipur, Rajasthan

6.25 COST CONTROL

6.25.1 Bill of Quantities

6.25.1.1 The Bill of Quantities contains items for the construction, installation, testing, and commissioning work to be done by the Contractor.

6.25.1.2 The Bill of Quantities is used to calculate the Contract Price. The Contractor shall be paid for the quantity of the work to be done at the rate quoted/negotiated in the Bill of Quantities for each item.

6.25.2 Changes in the Scope of work

6.25.2.1 The Employer reserves the right to increase, decrease or change/alter the scope of any component of work by proposing new work that is not reflected in scope of work/ drawings of the original contract. The contractor will be bound to comply with the order of the competent authority for execution of said work. The cost of the said work if not adjustable within the contract cost shall be variation item for which the rate / cost shall be payable as per mutual consent after approval of competent authority/ employer. The contractor shall submit detailed analysis for such item of work after variation is proposed by the Engineer-in-Charge.

6.25.2.2 The contractor shall not make any additional claim for an item of work which is reflected in scope of work/ drawings. In case of increase/reduction in any item of work as per the agreed payment schedule, the cost of such item of work shall be adjustable within the overall cost of the contract.

The rate for new item shall be derived and paid based on:

- a) adopting the analysis of rates of MORTH/CPWD/RUIDP/ PWD , irrespective of the tender premium or discount.
- b) on the minimum market rates of the materials, labour, and direct and indirect expenses constituting the item.

6.25.2.3 The new analyzed rate shall require approval of the Employer before enactment.

6.25.3 Variations

6.25.3.1 Variations may be initiated by the Engineer at any time prior to issuing the Taking over Certificate for the Works, either by an instruction or by a request for the Contractor to submit a proposal.

6.25.3.2 The Contractor shall execute and be bound by each Variation, unless the Contractor promptly gives notice to the Engineer stating (with supporting particulars) that (i) the Contractor cannot readily obtain the Goods required for the Variation, or (ii) such Variation triggers a substantial change in the sequence or progress of the Works. Upon receiving this notice, the Engineer shall cancel, confirm or vary the instruction.

6.25.3.3 All variations shall be included in updated Programs produced by the Contractor.

6.25.3.4 Each Variation may include:

- a) changes in scope of the work not included in contract cost.
 - b) For change in quantities of items of work within the scope of the contract appropriation
-

RFP for Development of three Child and Family-friendly junctions and 1.5km Connected shared Street at Saheli Marg and Big Bazar Rd, Udaipur, Rajasthan

shall be applicable as per agreed payment schedule break up within the overall contract cost. However, such changes shall not come under variation.

- c) omission of any work unless it is to be carried out by others,
- d) any additional work, Plant, Materials or services necessary for the Permanent Works, including any associated Tests on Completion, boreholes and other testing and exploratory work, or

6.25.3.5 The Contractor shall not make any alteration and/or modification of the Permanent Works, unless and until the Engineer instructs or approves a Variation

6.25.3.6 Variation procedure

If the Engineer requests a proposal, prior to instructing a Variation, the Contractor shall respond in writing as soon as practicable, either by giving reasons why he cannot comply (if this is the case) or by submitting:

- a) a description of the proposed work to be performed and a programme for its execution,
- b) the Contractor's proposal for any necessary modifications to the programme according to
- c) clause 6.23 Work Programme, and to the Time for Completion, and the Contractor's proposal for evaluation of the Variation.

The Engineer shall, as soon as practicable after receiving such proposal respond with approval, disapproval or comments. The Contractor shall not delay any work whilst awaiting a response. Each instruction to execute a Variation, with any requirements for the recording of Costs, shall be issued by the Engineer to the Contractor, who shall acknowledge receipt. Each Variation shall be evaluated in accordance with Clause 6.25.7 [Measurement and Evaluation], unless the Engineer instructs or approves otherwise in accordance with this Clause.

6.25.4 Payments to Variations

- a) If the work in the Variation corresponds with similar item in the Bill of Quantities, the rate in the bill of Quantities shall be used as base rate and rate for varied item be arrived at.
- b) If the varied item is altogether a new item of work, then the rate for the item of work shall be derived and paid based on the minimum market rates of the materials, labour, and direct and indirect expenses constituting the item adopting the analysis of rates of MORTH/ CPWD/ State SoR, irrespective of the tender premium or discount.
- c) The contractor shall not be entitled to additional payment for costs which could have been avoided by giving early warning.
- d) There shall be a Variation Agreement signed by the Employer and Contractor for every variation order or a group of variation orders if the Employer so desires. Every Variation agreement when signed by the contractor shall be considered to be in full, final and fair compensation for the variation(s) ordered and the contractor. shall be deemed to have waived any further claim in respect of the particular variation order(s) even when it is not expressly written in the Variation Agreement.

6.25.5 Cash Flow Forecasts

6.25.5.1 The contractor shall submit a planned value statement along with the work programme for the full contract period containing cumulative future quarterly expenditures.

RFP for Development of three Child and Family-friendly junctions and 1.5km Connected shared Street at Saheli Marg and Big Bazar Rd, Udaipur, Rajasthan

6.25.5.2 The Contractor shall revise the work programme and update the quarterly planned value statement and submit it to the Engineer in the first week of every financial quarter.

6.25.6 Payment Certificates

6.25.6.1 The Contractor shall submit to the Engineer monthly priced statements of the completed and accepted work less the cumulative amount certified previously, along with copies of the following documents: -

- a) Measurements and quantities of items of works done since last bill.
- b) Copies of quality control tests in specified format covering the work done since last bill.
- c) Copies of instructions recorded in the Instruction Book containing the instructions and compliance thereof, covering the work done since last bill.

6.25.6.2 The Engineer shall check the Contractor's statement within 14 days and certify the amount to be paid to the Contractor as per contract payment schedule.

6.25.6.3 The value of work executed shall be determined by the Engineer. The value of work executed shall comprise the value of the quantities of the items as per the agreed payment schedule and work programme attached to the contract.

6.25.6.4 The Engineer shall maintain and update the earned value statement every month.

6.25.6.5 The value of work executed shall include the valuation of Change in Scope (Variation) and Compensation Events, if any.

6.25.6.6 The Engineer may exclude any item certified in a previous certificate or reduce the proportion of any item previously certified in any certificate in the light of later information.

6.25.7 Measurements, Evaluation and Payments

6.25.7.1 Measurements

The Works shall be measured, and valued for payment, in accordance with this Clause. The Contractor shall show in each application for Interim Payment Certificates, Statement on Completion and Application for Final Payment Certificate the quantities and other particulars detailing the amounts which he considers to be entitled under the Contract. Whenever the Engineer requires any part of the Works to be measured,

reasonable notice shall be given to the Contractor's Representative, who shall:

1. promptly either attend or send another qualified representative to assist the Engineer in making the measurement, and
2. supply any particulars requested by the Engineer.

If the Contractor fails to attend or send a representative, the measurement made by (or on behalf of) the Engineer shall be accepted as accurate. Except as otherwise stated in the Contract, wherever any Permanent Works are to be measured from records, these shall be prepared by the Engineer. The Contractor shall, as and when requested, attend to examine and agree the records with the Engineer, and shall sign the same when agreed. If the Contractor does not attend, the records shall be accepted as accurate. If the Contractor examines and disagrees the records, and/or does not sign them as agreed, then the Contractor shall give notice to the Engineer of the respects in which the records are asserted to be inaccurate. After receiving this notice, the Engineer shall review the records and either

RFP for Development of three Child and Family-friendly junctions and 1.5km Connected shared Street at Saheli Marg and Big Bazar Rd, Udaipur, Rajasthan

confirm or vary them and certify the payment of the undisputed part. If the Contractor does not so give notice to the Engineer within 14 days after being requested to examine the records, they shall be accepted as accurate.

6.25.8 Method of Measurement

Except as otherwise stated in the Contract and notwithstanding local practice:

1. measurement shall be made of the net actual quantity of each item of the Permanent Works, and
2. the method of measurement shall be in accordance with the Bill of Quantities or other applicable Schedules

6.25.9 Payment Schedule

6.25.9.1 Payment shall be made to the Contractor upon production of monthly invoice. The Employer shall pay the Contractor the amounts certified by the Engineer within 14 days from the date of each certificate. If the Employer makes a late payment, the Contractor shall be paid interest on the late payment. Interest shall be calculated from the date by which the payment should have been made up to the date when the late payment is made at the prevailing savings bank interest rates.

6.25.9.2 Items of the Works not entered in Scope of work/ Summary sheet, will not be paid by the Employer and shall be deemed to be covered by other rates and prices in the Contract.

6.25.9.3 Payments shall be adjusted for deductions for any advance payments, retention, other recoveries in terms of the contract and taxes at source, as applicable under the law.

6.25.10 Compensation Events

The following are Compensation Events unless they are caused by the Contractor:

- a) The Employer does not give access to a part of the Site by the Site Possession Date stated in the Contract Data.
 - b) The Employer modifies the schedule of other contractors in a way which affects the work of the Contractor under the Contract.
 - c) The Engineer orders a delay or does not issue drawings, specifications or instructions required for execution of works on time.
 - d) The Engineer instructs the Contractor to uncover or to carry out additional tests upon work which is then found to have no Defects.
 - e) The Engineer does not approve for a Sub-Contract to be let for more than 15 days.
 - f) Ground conditions are substantially more adverse than could reasonably have been assumed before issuance of Letter of Award from the information issued to bidders (including the site investigation reports), for information available publicly and from a visual inspection of the site.
 - g) The Engineer gives an instruction for dealing with an unforeseen condition, caused by the employer, or additional work required for safety or other reasons.
 - h) The advance payment is delayed, beyond 28 days after receipt of application and bank guarantee, and after getting confirmation from the issuing bank.
 - i) The effect on the Contractor of any of the Employer's Risks.
-

RFP for Development of three Child and Family-friendly junctions and 1.5km Connected shared Street at Saheli Marg and Big Bazar Rd, Udaipur, Rajasthan

- j) The Engineer unreasonably delays issuing a Certificate of Completion.
- k) Other Compensation Events listed in the Contract Data or mentioned in the Contract.
- l) The contractor shall give a notice not later than 14 days after the contractor became aware or should have become aware of the event or circumstance.

6.25.10.1 If a Compensation Event would prevent the work being completed before the Intended Completion Date, the Intended Completion Date shall be extended. The Engineer shall decide whether and by how much the Intended Completion Date shall be extended.

6.25.10.2 If a Compensation Event would cause additional cost, the Contract Price shall be increased. The Engineer shall treat the event as "variation" as per Clause no.6.25.3 and ascertain the additional cost.

6.25.10.3 As soon as Contractor's forecast cost has been provided by the Contractor, it is to be assessed by the Engineer and the Contract Price shall be adjusted accordingly. If the Contractor's forecast is deemed unreasonable, the Engineer shall adjust the Contract Price based on Engineer's own forecast. The Engineer will assume that the Contractor will react competently and promptly to the event.

6.25.10.4 The Contractor shall not be entitled to compensation to the extent that the Employer's interests are adversely affected by the Contractor not having given early warning or not having cooperated with the Engineer.

6.25.11 Tax

6.25.11.1 The rates quoted by the Contractor shall be deemed to be inclusive of the GST as per prevailing rates, Royalty, Income Tax, Service Tax, Labour CESS and all other statutory taxes that the Contractor will have to pay for the performance of this Contract in the Union Territory of Udaipur & Kashmir. The Employer will perform such duties in regard to the deduction of such taxes at source as per the applicable laws.

6.25.11.2 Nothing in the contract shall relieve the Contractor from its responsibility to pay any tax that may be levied in India on profits made or otherwise by it in respect of the contract. The Contractor shall comply with the proper bye-laws and legal orders of the local body or public authority under the jurisdiction of which the work is executed and pay all fees and charges for which he may be liable. Nothing extra shall be payable on this account.

6.25.12 Currencies

6.25.12.1 All payments shall be made-in Indian Rupees.

6.25.13 Price Adjustment

6.25.13.1 There will be no Price Adjustment

6.25.14 Retention Money

6.25.14.1 The Employer shall retain from each payment due to the Contractor the proportion stated in the Contract Data until Completion of the whole of the works or settlement of final payment.

6.25.14.2 On physical completion of the whole of the Works, half the total amount retained is

RFP for Development of three Child and Family-friendly junctions and 1.5km Connected shared Street at Saheli Marg and Big Bazar Rd, Udaipur, Rajasthan

repaid to the Contractor and half when the Defects Liability Period has passed and the Engineer has certified that all Defects notified by the Engineer to the Contractor before the end of this period have been corrected.

6.25.14.3 On completion of the whole works, the contractor may substitute retention money with an "on demand" Bank guarantee.

6.25.14.4 No retention money shall be deducted from the Advance payments.

6.25.15 Delay Damages

6.25.15.1 The Authority shall notify the Contractor its decision to impose Damages. The Contractor shall have opportunity to make any representation with regard to such notification within 20 days of the date of such notification.

6.25.15.2 The Contractor shall pay delay damages to the Employer at the rate per day stated in the Contract Data for each day that the Completion Date is later than the Intended Completion Date (for the whole of the works or the milestone as stated in the contract data). The total amount of delay damages shall not exceed the amount defined in the Contract Data. The Employer may deduct delay damages from payments due to the Contractor.

6.25.15.3 If the Intended Completion Date is extended after delay damages have been paid, the Engineer shall correct any overpayment of delay damages by the Contractor by adjusting the next payment certificate.

6.25.15.4 If the contractor fails to comply with the time for completion as stipulated in the tender, then the contractor shall pay to the employer the relevant sum stated in the Contract Data as delay damages for such default and not as penalty for everyday or part of day which shall elapse between relevant time for completion and the date stated in the taking over certificate of the whole of the works on the relevant section, subject to the limit stated in the contract data.

6.25.15.5 The employer may, without prejudice to any other method of recovery deduct the amount of such damages from any money due or to become due to the contractor. Payment or deduction of delay damages shall not relieve the Contractor from his obligation to complete the work as per agreed construction program and milestones or from any other of the contractor's obligations and liabilities under the contract.

6.25.15.6 If, before the Time for Completion of the whole of the Works or, if applicable, any Section, a Taking-over Certificate has been issued for any part of the Works or of a Section, the delay damages for delay in completion of the remainder of the Works or of that Section shall, for any period of delay after the date stated in such Taking-over Certificate, and in the absence of alternative provisions in the Contract, be reduced in the proportion which the value of the part so certified bears to the value of the whole of the Works or Section, as applicable. The provisions of this Sub-Clause shall only apply to the rate of delay damages and shall not affect the limit thereof.

6.25.15.7 Concurrent Delays: - If there are two or more causes of delay which happen concurrently or overlap and some but not all of those causes of delay would entitle the contractor to an EOT, then for the period of such overlap the contractor will be entitled to an

RFP for Development of three Child and Family-friendly junctions and 1.5km Connected shared Street at Saheli Marg and Big Bazar Rd, Udaipur, Rajasthan

EOT but not delay damages.

6.25.15.8 Delay damages to the contractor:- The quantum of delay damages to be paid to the contractor, on account of a critical delay caused by Employer, shall be calculated on the basis of cost plus overhead and profit wherein cost shall be calculated using the approved bill of quantities of the contract, the overhead and profit shall be limited to the overhead and profit percentage of the cost of works executed during the critical delay period, as per the RUIDP/PWD Rajasthan schedule of rates at the time of event leading to delays. By accepting these General & Particular conditions of the contract, the successful contractor is accepting that he will not resort to any legal action contravening this clause.

6.25.16 Advance Payment

6.25.16.1 The Employer shall make payment to the Contractor of the amounts stated in the Contract Data, by the date stated in the Contract Data, against provision by the Contractor of an unconditional bank guarantee in a form acceptable to the Employer issued by a Nationalized Bank/ Scheduled Commercial Bank for the amount equal to the advance payment. The guarantee shall remain effective until the advance payment has been repaid, but the amount of the guarantee shall be progressively reduced by the amounts repaid by the Contractor. Interest will be charged at the prevalent Prime Lending Rate of RBI on the advance payment.

6.25.16.2 The Contractor is to use the advance payment only to pay for Mobilization expenses required specifically for execution of the Works. The Contractor shall demonstrate that advance payment has been used in this way by supplying copies of invoices or other documents to the Employer.

6.25.16.3 The advance payment shall be repaid by deducting proportionate amounts from payments otherwise due to the Contractor, following the schedule of completed percentages of the Works on a payment basis. No account shall be taken of the advance payment or its repayment in assessing valuation of the work done,

6.25.16.4 Variations, price adjustments, compensation events or liquidated damages.

6.25.17 Secured Advance (Not Applicable)

6.25.18 Performance Security

6.25.18.1 The Performance Security shall be provided to the Employer no later than the date specified in the Letter of Award and shall be issued in an amount as specified in the Contract Data and in form and by a bank acceptable to the Employer. The Performance Security shall be valid until a date 60 days beyond the expiry of the Defect Liability Period. The release of Performance Security shall be as per the Condition mentioned in Contract data.

6.25.18.2 In case where the bid of the successful bidder is seriously unbalanced or front loaded, the Employer may require that the amount of Performance Security set forth above, be increased at the expense of successful bidder to a level sufficient to protect the Employer against financial loss in the event of default of the successful bidder under the Contract.

6.25.18.3 The performance security shall be in the form of an unconditional irrevocable bank guarantee issued by a scheduled nationalized/ scheduled commercial bank in the

RFP for Development of three Child and Family-friendly junctions and 1.5km Connected shared Street at Saheli Marg and Big Bazar Rd, Udaipur, Rajasthan

amount(s) of **10%** of the contract price and shall be submitted within 07 days of the letter of award.

6.25.18.4 If the Bid, which results in the lowest evaluated bid price, is seriously imbalanced or front loaded in the opinion of the UMC, by more than 25% in relation to UMC's estimate of the cost of work to be performed under the Contract, the UMC may require the Bidder to produce detailed price analysis for any or all items of the Bill of Quantities to demonstrate the internal consistency of those prices with the construction methods and schedule proposed. After evaluation of the price analysis, taking into consideration the schedule of estimated Contract payments, the UMC may require that the amount of the performance security be increased to a maximum of 10% of the bid value of such items at the expense of the Bidder to a level sufficient to protect the UMC against financial loss in the event of default by the successful Bidder under the Contract.

6.25.18.5 The Performance Security (including additional security for unbalanced bids) shall be provided to the Engineer-in-charge on behalf of the UMC in an amount and form and by a bank or surety acceptable to the UMC and denominated in Indian Rupees. The Performance Security shall be in favour of the (UMC and valid until a date sixty (60) days pursuant to the date of expiry of the Defect Liability Period and the additional security for unbalanced bids shall be valid until the issue of the Certificate of Construction Completion.

6.25.18.6 The proceeds of the Performance Security shall be forfeited and shall be payable as compensation to the UMC on happening of any of the events mentioned below:

- a) when the Contractor does not execute the agreement within the specified time after issue of letter of award/ placement of work order; or
- b) when the Contractor fails to commence the work within the time specified; or
- c) when the Contractor fails to complete the work satisfactorily within the time specified; or
- d) when any terms and conditions of the contract is breached by the Contractor; or
- e) failure by the Contractor to pay the UMC any amount due, either as agreed by the Contractor or determined under any of the Sub-Clauses of these Conditions or another agreement, within 30 Days of the service of notice to this effect by Engineer-in-Charge.

6.25.18.7 The UMC shall return the Performance Security to the Contractor as below after completion of all obligations under the Contract, more specifically, after the expiry of 60 (sixty) days from the end of the Defect Liability Period provided there are no outstanding claims of the UMC against the Contractor. In the event of the Contract being determined or rescinded due to default of the Contractor, the Performance Security shall stand forfeited in full and shall be absolutely at the disposal of the UMC.

6.25.19 Cost of Repairs

6.25.19.1 Loss or damage to the Works or Materials to be incorporated in the Works between the Start Date and the end of the Defects liabilities periods shall be remedied by the Contractor at the Contractor's cost if the loss or damage arises from the Contractor's acts or omissions including the situation as stipulated at Clause 6.10.3.

RFP for Development of three Child and Family-friendly junctions and 1.5km Connected shared Street at Saheli Marg and Big Bazar Rd, Udaipur, Rajasthan

6.26 FINISHING THE CONTRACT

6.26.1 Completion

6.26.1.1 The Contractor shall request the Engineer-in-charge to issue a Project Completion Certificate of the Completed Works and the Engineer-in-charge along with other concerned experts and concerned Engineer-in-Charge, within thirty (30) days of the receipt of such request, shall inspect the Work. If there is no defect in the Work, the Engineer-in-charge shall furnish the Contractor with such a certificate of Project completion. In the event, some defects or shortcoming or non-compliance is noticed by the Engineer-in-charge, the Contractor shall be liable to repair such defects and remove the deficiencies pointed out within the period specified. In the event, the Contractor fails to do so the UMC may get the works rectified at the risk and cost of the Contractor. Further, the Contractor shall be liable to pay Damages @ 0.01% of the Contract Price for each day of delay until the work is done.

6.26.1.2 At least 20 (twenty) days prior to completion, the Contractor may apply by notice to the Engineer-in-charge for Taking-Over Certificate for taking over the Spaces/ Works by UMC. If the Works are divided into Sections, the Contractor may similarly apply for a Taking-Over Certificate for each Section. The Engineer-in-charge shall, after receiving the Contractor's application:

- a) Issue the Taking-Over Certificate to the Contractor, provided there are no defects or deficiencies; or
- b) Reject the application, giving reasons and specifying the work required to be done by the Contractor to enable the Taking-Over Certificate to be issued. The Contractor shall then complete this work before issuing a further notice under this Sub-Clause.

6.26.2 Final Account

6.26.2.1 The Contractor shall supply to the Engineer a detailed account of the total amount that the Contractor considers payable under the Contract before the end of the Defects Liability Period. The Engineer shall issue a Defect Liability Certificate and certify any final payment that is due to the Contractor within 60 days of receiving the Contractor's account if it is correct and complete. If it is not, the Engineer shall issue within 40 days a schedule that states the scope of the corrections or additions that are necessary. If the Final Account is still unsatisfactory after it has been resubmitted, the Employer shall decide on the amount payable to the Contractor and issue a payment certificate, within 30 days of receiving the Contractor's revised account.

6.26.3 Operation & Maintenance

During the aforesaid period of 01 year of DLP and 05 years of O&M, the Contractor shall be solely responsible for undertaking operation, maintenance including undertaking minor/ major repairs that may be required from time to time and remedying/ repairing, restoring to the original condition any apparent, virtual or observed defects, deficiencies in the Works, or its performance as per the Scope of Work & specifications, to the satisfaction of the Engineer-in-charge. If the Contractor fails to repair & restore the defect/deficiency after a notice issued by the Engineer-in-Charge, the UMC will be free to get it remedied at the risk and cost of the Contractor besides other action being taken as per the Contract, if the Contractor

RFP for Development of three Child and Family-friendly junctions and 1.5km Connected shared Street at Saheli Marg and Big Bazar Rd, Udaipur, Rajasthan

does not get it remedied within the period specified in such notice.

6.26.4 As-Built Drawings

6.26.4.1 If "as built" Drawings and/or operating and maintenance manuals (O&M Manual) are required, the Contractor shall supply them in scale as directed by the dates and in the format stated in the Contract Data.

6.26.4.2 If the Contractor does not supply the Drawings and/or manuals by the dates stated in the Contract Data, or they do not receive the Employer's approval, the Engineer shall withhold the amount stated in the Contract Data from payments due to the Contractor.

6.26.5 Termination

6.26.5.1 The Employer or the Contractor may terminate the Contract if the other party causes a fundamental breach of the Contract. For this purpose, 14 (fourteen) days notice in writing shall be served by either party on the other party clearly mentioning the particular grounds of Breach of Contract with a copy to the Engineer-in-charge.

6.26.5.2 Fundamental breaches of Contract include, but shall not be limited to the following:

- a) the Contractor stops work for 28 days when no stoppage of work is shown on the current Programme and the stoppage has not been authorized by the Engineer;
- b) the Employer or the Contractor is made bankrupt or goes into liquidation other than for a reconstruction or amalgamation;
- c) the Engineer gives Notice that failure to correct a particular Defect is a fundamental breach of Contract and the Contractor fails to correct it within a reasonable period of time determined by the Engineer;
- d) the Contractor does not maintain a security which is required;
- e) the Contractor has delayed the completion of works by the number of days for which the maximum amount of liquidated damages can be paid as defined in the Contract data; and
- f) if the Contractor, in the judgment of the Employer has engaged in corrupt or fraudulent practices in competing for or in executing the Contract,
- g) Non deployment of professionals as per Qualification Information

6.26.5.3 When either party to the Contract gives notice of a breach of contract to the Engineer for a cause other than those listed under Clause 6.26.5.2 above, the Engineer shall decide whether the breach is fundamental or not.

6.26.5.4 Notwithstanding the above, the Employer may terminate the Contract for convenience.

6.26.5.5 If the Contract is terminated, the Contractor shall stop work immediately, make the Site safe and secure and leave the Site, as soon as reasonably possible.

6.26.5.6 After the termination of the contract under this clause, the employer shall be at liberty to get the balance work executed through some other contractual agency or through departmental means or to abandon the balance work altogether or to modify the design and scope of the work in any manner. The contractor shall have no claim against the

RFP for Development of three Child and Family-friendly junctions and 1.5km Connected shared Street at Saheli Marg and Big Bazar Rd, Udaipur, Rajasthan

Employer in this regard.

6.26.6 Payment upon Termination

6.26.6.1 If the-Contract is terminated because of a fundamental breach of Contract by the Contractor, the Engineer shall issue a certificate for the value of the work done less advance payments received up to the date of the issue of the certificate, less other recoveries due in terms of the contract, less taxes due to be deducted at source as per applicable law and less the percentage to apply to the work not completed as indicated in the Contract Data. Additional Liquidated Damages shall not apply. If the total amount due to the Employer exceeds any payment due to the Contractor, the difference shall be a debt payable to the Employer.

6.26.6.2 If the Contract is terminated because of fundamental breach of contract by the Employer, the Engineer shall issue a certificate for the value of the work done, less advance payments received up to the date of the certificate, less other recoveries due in terms of the contract and less taxes due to be deducted at source as per applicable law. No extra cost will be paid by the employer for expenditure towards removal of Equipment, repatriation of the Contractor's personnel employed solely on the Works and the Contractor's costs of protecting and securing the Works.

6.26.7 Property

6.26.7.1 All materials on the Site, Plant, Equipment, Temporary Works and Works are deemed to be the property of the Employer, if the Contract is terminated because of a contractor's default.

6.26.8 Release from Performance

6.26.8.1 If the Contract is frustrated by the outbreak of war or by any other event entirely outside the control of either the Employer or the Contractor, the Engineer shall certify that the Contract has been frustrated. The Contractor shall make the Site safe and stop work as quickly as possible after receiving this certificate and shall be paid for all works carried out before receiving it and for any work carried out afterwards to which commitment was made.

6.26.9 Fraud and Corruption

6.26.9.1 If the Employer determines that the Contractor has engaged in corrupt, fraudulent, collusive, coercive or obstructive practices, in competing for or in executing the Contract, then the Employer may, after giving 14 days' notice to the Contractor, terminate the Contractor's employment under the Contract and expel him from the Site, and the provisions of Clause 6.26.52f shall apply as if such expulsion had been made under Clause 6.26.5.2 (f) [Termination by Employer].

6.26.9.2 Should any employee of the Contractor be determined to have engaged in corrupt, fraudulent, collusive, coercive, or obstructive practice during the execution of the Works, then that employee shall be removed in accordance with Clause 6.26.5.

6.26.9.3 For the purposes of this Sub-Clause:

RFP for Development of three Child and Family-friendly junctions and 1.5km Connected shared Street at Saheli Marg and Big Bazar Rd, Udaipur, Rajasthan

- a) "Corrupt practice" means the offering, giving, receiving or soliciting of anything of value to influence the action of a public official in the procurement process or in contract execution; and
- b) "Fraudulent practice" means a misrepresentation of facts in order to influence a procurement process or the execution of a contract to the detriment of the Employer and includes collusive practice among Bidders
- c) (prior to or after bid submission) designed to establish bid prices at artificial non-competitive levels and to deprive the Government of the benefits of free and open competition.
- d) "Collusive practice" is an arrangement between two or more parties designed to achieve an improper purpose, including to influence improperly the actions of another party;
- e) "Coercive practice" is impairing or harming, or threatening to impair or harm, directly or indirectly, any party or the property of the party to influence improperly the actions of a party.

6.26.10 Contractor's Claims

6.26.10.1 If the Contractor considers himself to be entitled to any extension of the Time for Completion and/or any additional payment, under any Clause of these Conditions or otherwise in connection with the Contract, the Contractor shall give notice to the Engineer, describing the event or circumstance giving rise to the claim. The notice shall be given as soon as practicable, and not later than 28 days after the Contractor became aware, or should have become aware, of the event or circumstance.

6.26.10.2 If the Contractor fails to give notice of a claim within such period of 28 days, the Time for Completion shall not be extended, the Contractor shall not be entitled to additional payment, and the Employer shall be discharged from all liability in connection with the claim. Otherwise, the following provisions of this Sub- Clause shall apply.

- a) The Contractor shall also submit any other notices which are required by the Contract, and supporting particulars for the claim, all as relevant to such event or circumstance.
 - b) The Contractor shall keep such contemporary records as may be necessary to substantiate any claim, either on the Site or at another location acceptable to the Engineer. Without admitting the Employer's liability, the Engineer may, after receiving any notice under this Sub-Clause, monitor the record-keeping and/or instruct the Contractor to keep further contemporary records. The Contractor shall permit the Engineer to inspect all these records, and shall (if instructed) submit copies to the Engineer.
 - c) Within 42 days after the Contractor became aware (or should have become aware) of the event or circumstance giving rise to the claim, or within such other period as may be proposed by the Contractor and approved by the Engineer, the Contractor shall send to the Engineer a fully detailed claim which includes full supporting particulars of the basis of the claim and of the extension of time and/or additional payment claimed.
 - d) If the event or circumstance giving rise to the claim has a continuing effect:
 - i. this fully detailed claim shall be considered as interim;
 - ii. the Contractor shall send further interim claims at monthly intervals, giving the accumulated delay and/or amount claimed, and such further particulars as the
-

RFP for Development of three Child and Family-friendly junctions and 1.5km Connected shared Street at Saheli Marg and Big Bazar Rd, Udaipur, Rajasthan

Engineer may reasonably require; and

- iii. the Contractor shall send a final claim within 28 days after the end of the effects resulting from the event or circumstance, or within such other period as may be proposed by the Contractor and approved by the Engineer.
 - e) Within 42 days after receiving a claim or any further particulars supporting a previous claim, or within such other period as may be proposed by the Engineer and approved by the Contractor, the Engineer shall respond with approval, or with disapproval and detailed comments. He may also request any necessary further particulars, but shall nevertheless give his response on the principles of the claim within the above defined time period.
 - f) Within the above defined period of 42 days, the Engineer shall proceed to agree or determine (i) the extension (if any) of the Time for Completion (before or after its expiry) in accordance with Clause 6.23.7 Extension of Time for Completion], and/or (ii) the additional payment (if any) to which the Contractor is entitled under the Contract.
 - g) Each Payment Certificate shall include such additional payment for any claim as has been reasonably substantiated as due under the relevant provision of the Contract. Unless and until the particulars supplied are sufficient to substantiate the whole of the claim, the Contractor shall only be entitled to payment for such part of the claim as he has been able to substantiate.
 - h) If the Engineer does not respond within the timeframe defined in this Clause, either Party may consider that the claim is rejected by the Engineer and any of the Parties may proceed as laid down in Clause 6.27.8 of this Contract- Procedure for Disputes.
-

RFP for Development of three Child and Family-friendly junctions and 1.5km Connected shared Street at Saheli Marg and Big Bazar Rd, Udaipur, Rajasthan

6.27 Particular Conditions of Contract

6.27.1 Contract Conditions

6.27.1.1 Contractors are advised to inspect the Site of Work before bidding/ tendering.

6.27.1.2 All the Works shall be carried out as per Specification and instructions of Engineer-in-charge.

6.27.1.3 The conditional tender shall be liable to be rejected.

6.27.1.4 The quantities provided in the BOQ is an estimate, though care has been taken to cover all items in work and the entire scope work. The Summary of works in the BOQ shall be used primarily to enable the stage payment as per actual work done. Quantities are liable to vary on either side to any extent as per actual requirement of work for which no claim whatsoever by the contractor shall be entertained.

6.27.1.5 The Drawings provided are only indicative. The contractor should develop working drawings for each element and get them approved by the Engineer prior to construction.

6.27.1.6 Any recovery imposed by Technical Audit cell or by other competent authority on account of defects identified in the Works, will be deducted from Contractors running final bills during execution of works

6.27.1.7 All the Defects that appear during execution of work will have to be rectified as directed by Engineer-in-charge within the shortest possible time. If Contractor fails to attend to the defects within reasonable time period, the same will be got rectified by the employer and all expense so incurred will be adjusted from the Running Account bills of the Contractor, and 1.5 times of the expense so incurred will be adjusted from any monies due to the Contractor or from performance security of the Contractor.

6.27.1.8 In case any operation connected with the works necessitates diversion, obstruction or closure of any road or any other right of way, the approval of the Engineer-in-charge or the Engineer's Representative and the respective competent authorities shall be obtained well in advance by the Contractor. In case the Contractor's operations obstruct access to adjacent properties, the Contractor shall be responsible to provide reasonable temporary access to the affected parties. The Contractor will also be responsible to ensure completion of his work with utmost effort in earliest possible period to ensure minimum inconvenience to the public at large. If in the opinion of the Engineer-in-Charge, the work has not been done in time and the passage way not restored satisfactorily in time, he may after giving a notice of seven days have the work done through any other agency. He will in these circumstances enter the work done as work done by the contractor in measurement book and pay for the same to the contractor and also recover the actual cost paid by him for the work plus 5% of the value of this work from the payments or any other money due to the contractor.

6.27.1.9 During the execution of work obtaining electricity and water supply for the execution of works, will be in the scope of contractor.

6.27.1.10 The Contractor shall place order for the material and the equipment only after approval of the Engineer-in-charge. The Contractor shall submit material approval requests and the detailed drawings to the Engineer-in-charge for approval. All the items have to be

RFP for Development of three Child and Family-friendly junctions and 1.5km Connected shared Street at Saheli Marg and Big Bazar Rd, Udaipur, Rajasthan

approved by the Engineer-in-charge prior to planting on site. Provided however, the testing, approval for dispatching shall not absolve the Contractor's obligations for satisfactory performance of the equipment/material. Before commencement of every element of work the Contractor has to submit to the Engineer -in- Charge a Request for Inspection (RFI) and get approval for the same.

6.27.2 Site office

The contractor shall setup a site office for his technical staff as well as for PMC/client and a permanent board shall be erected at the site displaying the details of the work including contract amount, period of contract, scheduled date of completion of work, name of Contractor & Consultant etc.

The following details shall be available in the site office at all times:

- a) All GFC drawings like plan, elevation, layout plan, sections, R.C.C. details, alignment plan etc. shall be maintained in site office. Such plans are required for daily reference and during the inspection of higher officers. Such drawings shall bear the signatures of officers approving such drawings, to avoid use of any other drawing outdated or superseded drawings shall be clearly marked as such and removed from the site.
- b) The contract copy containing all documents shall be kept at site for study, other registers are also required to be maintained like stock record, manpower details, test records of the materials, concrete cubes tests etc.

6.27.3 Good Engineering Practice

In respect of the Contractor, its subcontractors, and all other such third-party agents of the Contractor, practices, methods, techniques and standards, as changed from time to time, that are generally accepted for use internationally and all other facility during construction, development, operations and maintenance, taking into account conditions in India shall be adhered to.

6.27.4 Labour (Clause 6.14.2 of Conditions of Contract):

6.27.5 Engagement of all Staff and Labour:

The Contractor shall, unless otherwise provided in the Contract, make his own arrangements for the engagement of all staff and labour, local or other, and for their payment, housing, feeding and transport. The Contractor shall, if required by the Engineer, deliver to the Engineer a return in detail, in such form and at such intervals as the Engineer may prescribe, showing the staff and the numbers of the several classes of labour from time to time employed by the Contractor on the Site and such other information as the Engineer may require.

6.27.6 Compliance with Labour Regulations:

During continuance of the contract, the Contractor and his sub-contractors shall abide at all times by all existing labour enactments and rules made there under, regulations, notifications and bye laws of the State or Central Government or local authority and any other labour law (including rules), regulations, bye laws that may be passed or notification that may be issued under any labour law in future either by the State or the Central Government or the local

RFP for Development of three Child and Family-friendly junctions and 1.5km Connected shared Street at Saheli Marg and Big Bazar Rd, Udaipur, Rajasthan

authority. Salient features of some of the major labour laws that are applicable to construction industry are given below.

The Contractor shall keep the Employer indemnified in case any action is taken against the Employer by the competent authority on account of contravention of any of the provisions of any Act or rules made there under, regulations or notifications including amendments. If the Employer is caused to pay or reimburse, such amounts as may be necessary to cause or observe, or for non-observance of the provisions stipulated in the notifications/bye Laws/Acts/Rules/regulations including amendments, if any, on the part of the Contractor, the Engineer/Employer shall have the right to deduct any money due to the Contractor including his amount of performance security. The Employer/Engineer shall also have right to recover from the Contractor any sum required or estimated to be required for making good the loss or damage suffered by the Employer.

The employees of the Contractor and the Sub-Contractor in no case shall be treated as the employees of the Employer at any point of time.

6.27.7 Protection of Environment (Clause 6.14.3 of Conditions of Contract):

6.27.7.1 The Contractor shall take all reasonable steps to protect the environment on and off the Site and to avoid damage or nuisance to persons or to property of the public or other resulting from pollution, noise or other causes arising as a consequence of his methods of operation.

6.27.8 Disputes Resolution Mechanism

- a) If any dispute or differences of any kind what-so-ever arise between the UMC, its authorized representatives and the Contractor in connection with or arising out of this Contract or the execution of Work, it will be first attempted to be resolved amicably in accordance with the conciliation procedure set forth below Whether before its commencement or during the progress of Project/ Works or after the termination, abandonment or breach of the Contract, the dispute shall in the first instance supported with complete documents and further documents, if any, required by the other party, be referred for settlement to the Engineer-in- charge of the Works and he shall, within a period of thirty (30) days after being requested in writing by either party, mediate and convey his decision.
 - b) If the Employer has conveyed his decision and no claim for arbitration has been filed by either party within a period of thirty (30) days from the receipt of the letter communicating the decision, the said decision shall be final and binding upon the party and will not be a subject matter of arbitration at all.
 - c) If the meditation/ conciliation fails, either party may require such Dispute to be referred to the Chairman of Board of directors of UDAIPUR MUNICIPAL CORPORATION (UMC) and the Chairman or Chief Executive of the Contractor for amicable settlement; such persons shall meet within 7 days of the Dispute being referred to them. If the dispute is not amicably settled within 30(thirty) days of the matter being referred to the above persons, either party may refer the Dispute to arbitration.
 - d) All disputes or differences in respect of which the decision is not final and conclusive shall, at the request of either party made in communication sent through registered A.D. post,
-

RFP for Development of three Child and Family-friendly junctions and 1.5km Connected shared Street at Saheli Marg and Big Bazar Rd, Udaipur, Rajasthan

- be referred for arbitration by the Arbitral Tribunal consisting of the sole Arbitrator to be nominated by the Commissioner, UMC.
- e) The reference to the Arbitral Tribunal shall be made by the claimant party within one hundred twenty (120) days from the date of dispute of claim during the execution of Work. If the claim pertains to rates or recoveries introduced in the final bill, the reference to the Arbitral Tribunal shall be made within six (6) calendar months from the date of payment of the final bill to the Contractor or from the date a registered notice is sent by the Engineer-in-charge (whose decision in this respect shall be final and binding) to the Contractor to the effect that his final bill is ready, whichever is earlier.
- f) The provisions of the Arbitration and Reconciliation Act, 1996 or any other statutory law thereunder or modification thereof and for the time being in force shall apply to the arbitration proceedings under this clause.
- g) The Arbitrator/ Arbitral Tribunal shall give a reasoned award for each claim/ counter claim.
- h) The independent claims of the party other than one seeking arbitration as also the counter claims of any party shall be entertained by the arbitrator.
- i) The venue of arbitration shall be Udaipur, Rajasthan. The Works under the contract shall continue during the arbitration proceedings.
- j) The stamp fee due on the award shall be payable by the party as desired by the Arbitral Tribunal and in the event of such party's default, the stamp fee shall be recoverable from another sum due to such party under this or any other contract.
- k) Neither party shall be entitled to bring a claim for arbitration, if it is not filed as per the time period already specified or within six (6) months of the following: -
- i. of the date of completion of the Work as certified by the Engineer-in-charge, or
 - ii. of the date of abandonment of the Work or breach of Contract under any of its clauses, or
 - iii. of its non-commencement or non-resumption of Work within ten (10) days of written notice for commencement or resumption as applicable, or
 - iv. of the cancellation, termination or withdrawal of the work from the Contractor in whole or in part and/or revision for closure of the Contract, or
 - v. of receiving an intimation from the Engineer-in-charge that the final payment due or to be recovered from the Contractor had been determined, for the purpose of payment/adjustment whichever is the latest. If the matter is not referred to arbitration within the period prescribed above, all the rights and claims of either party under the contract shall be deemed to have been forfeited and absolutely barred by the time for arbitration and even for civil litigation.
- l) No question relating to this Contract shall be brought before any civil court without first invoking and completing the arbitration proceedings, if the issue is covered by the scope of arbitration under the Contract. The pending arbitration proceedings shall not disentitle the Engineer-in-charge to terminate the Contract and to make alternate arrangement for completion of the Works.
- m) Arbitral Tribunal shall be deemed to have entered into the reference on the day, notice is issued to the parties fixing the first date of hearing. The Arbitrator/Arbitral Tribunal may, from time to time, with the consent of the parties enlarge the initial time for making and
-

RFP for Development of three Child and Family-friendly junctions and 1.5km Connected shared Street at Saheli Marg and Big Bazar Rd, Udaipur, Rajasthan

publishing the award. However, the Arbitrator/Arbitral Tribunal shall make every effort to decide each claim within a period of six (6) months from the date of initiation.

n) The expiry to the contractual time limit, whether originally fixed or extended, shall not invalidate the provisions of this clause.

6.27.9 Force Majeure (Clause 6.10.1 Employer's Risks)

6.27.9.1 Definition of Force Majeure

In this Clause, "Force Majeure" means an exceptional event or circumstance:

- a) which is beyond a Party's control,
- b) which such Party could not reasonably have provided against before entering into the Contract,
- c) which, having arisen, such Party could not reasonably have avoided or overcome, and
- d) which is not substantially attributable to the other Party. Force Majeure may include, but is not limited to, exceptional events or circumstances of the kind listed below, so long as conditions (a) to (d) above are satisfied:
 - i. war, hostilities (whether war be declared or not), invasion, act of foreign enemies, rebellion, terrorism, sabotage by persons other than the Contractor's Personnel,
 - ii. revolution, insurrection, military or usurped power, or civil war, riot, commotion, disorder, strike or lockout by persons other than the Contractor's Personnel,
 - iii. munitions of war, explosive materials, ionising radiation or contamination by radio-activity, except as may be attributable to the Contractor's use of such munitions, explosives, radiation or radio-activity, and natural catastrophes such as earthquake, hurricane, typhoon or volcanic activity.

6.27.9.2 Notice of Force Majeure

If a Party is or will be prevented from performing its substantial obligations under the Contract by Force Majeure, then it shall give notice to the other Party of the event or circumstances constituting the Force Majeure and shall specify the obligations, the performance of which is or will be prevented. The notice shall be given within 14 days after the Party became aware, or should have become aware, of the relevant event or circumstance constituting Force Majeure. The Party shall, having given notice, be excused performance of its obligations for so long as such Force Majeure prevents it from performing them. Notwithstanding any other provision of this Clause, Force Majeure shall not apply to obligations of either Party to make payments to the other Party under the Contract.

6.27.9.3 Duty to Minimize Delay

Each Party shall at all times use all reasonable endeavours to minimise any delay in the performance of the Contract as a result of Force Majeure.

A Party shall give notice to the other Party when it ceases to be affected by the Force Majeure.

6.27.9.4 Consequences of Force Majeure

RFP for Development of three Child and Family-friendly junctions and 1.5km Connected shared Street at Saheli Marg and Big Bazar Rd, Udaipur, Rajasthan

If the Contractor is prevented from performing his substantial obligations under the Contract by Force Majeure of which notice has been given under Clause 6.27.9.2 [Notice of Force Majeure], and suffers delay and/or incurs Cost by reason of such Force Majeure, the Contractor shall be entitled subject to Sub-Clause 6.26.10 [Contractor's Claims] to:

- a) an extension of time for any such delay, if completion is or will be delayed, under Clause 6.23.7 Extension of the Intended time of completion
- b) if the event or circumstance is of the kind described in sub-paragraphs (i) to (iv) of Clause 6.27.9.1 [Definition of Force Majeure] and, in sub-paragraphs (ii) to (iv), occurs in the Country, payment of any such Cost, including the costs of rectifying or replacing the Works and/or Goods damaged or destroyed by Force Majeure, to the extent they are not indemnified through the insurance policy referred to in Clause 6.11 Insurances.

After receiving this notice, the Engineer shall proceed to determine these matters.

6.27.9.5 Force Majeure Affecting Subcontractor

If any Subcontractor is entitled under any contract or agreement relating to the Works to relief from force majeure on terms additional to or broader than those specified in this Clause, such additional or broader force majeure events or circumstances shall not excuse the Contractor's non-performance or entitle him to relief under this Clause.

6.27.9.6 Optional Termination, Payment and Release

If the execution of substantially all the Works in progress is prevented for a continuous period of 84 days by reason of Force Majeure of which notice has been given under Sub-Clause 6.27.9.2 [Notice of Force Majeure], or for multiple periods which total more than 140 days due to the same notified Force Majeure, then either Party may give to the other Party a notice of termination of the Contract. In this event, the termination shall take effect 7 days after the notice is given.

Upon such termination, the Engineer shall determine the value of the work done and issue a Payment Certificate which shall include:

- a) the amounts payable for any work carried out for which a price is stated in the Contract;
 - b) the Cost of Plant and Materials ordered for the Works which have been delivered to the Contractor, or of which the Contractor is liable to accept delivery: this Plant and Materials shall become the property of (and be at the risk of) the Employer when paid for by the Employer, and the Contractor shall place the same at the Employer's disposal;
 - c) other Cost or liabilities which in the circumstances were reasonably and necessarily incurred by the Contractor in the expectation of completing the Works;
 - d) the Cost of removal of Temporary Works and Contractor's Equipment from the Site and the return of these items to the Contractor's works and
 - e) the Cost of repatriation of the Contractor's staff and labour employed wholly in connection with the Works at the date of termination.
-

RFP for Development of three Child and Family-friendly junctions and 1.5km Connected shared Street at Saheli Marg and Big Bazar Rd, Udaipur, Rajasthan

6.27.9.7 Release from Performance

Notwithstanding any other provision of this Clause, if any event or circumstance outside the control of the Parties (including, but not limited to, Force Majeure) arises which makes it impossible or unlawful for either or both Parties to fulfil its or their contractual obligations or which, under the law governing the Contract, entitles the Parties to be released from further performance of the Contract, then upon notice by either Party to the other Party of such event or circumstance:

- a) the Parties shall be discharged from further performance, without prejudice to the rights of either Party in respect of any previous breach of the Contract, and
- b) the sum payable by the Employer to the Contractor shall be the same as would have been payable under Clause 6.27.9.6 [Optional Termination, Payment and Release]

RFP for Development of three Child and Family-friendly junctions and 1.5km Connected shared Street at Saheli Marg and Big Bazar Rd, Udaipur, Rajasthan

SECTION 7: CONTRACT DATA

7.1 CONTRACT DATA

7.1.1 Definitions

Name of the Project/Works: “Development of three Child and Family-friendly junctions and 1.5km Connected shared Street at Saheli Marg and Big Bazar Rd, Udaipur, Rajasthan”

The Contract Data hereunder pertains to some specific, but in no way exhaustive, information on the Project/Works. The Bidders are required to study and account for this data in conjunction to various other Sections of the Document. GCC stands for ‘General Conditions of Contract’. ITB stands for ‘Instructions to Bidders’.

| CONDITIONS | REF. CC CLAUSE | Data |
|--|----------------|---|
| Udaipur Municipal Corporation (UMC)'s name and address | 6.1.28 | Commissioner, UMC, Town Hall, Udaipur (Raj.), 313001 |
| Engineer-in-charge's name and address | 6.1.29 | Executive Engineer, Nirmaan, UMC |
| Earnest Money Deposit / Bid Security | 4.16 | INR₹ 3,38,000.00 In case of the Unsuccessful Bidders, the Bid Security will be returned to them without any interest, after expiry of the Bid validity period or not later than thirty (30) days after conclusion of the resultant contract whichever is earlier. The Successful Bidder's Bid Security will be returned without any interest, after receipt of Performance Security and Additional Performance Security, in case of unbalanced bids from that Bidder. |
| Defect Liability Period | 6.1.21 | Defect Liability Period: 01 year from the date of successful completion of project |
| Start Date | 6.1.42 | The start date of the contract shall be 07 (seven) days after the date of issue of LoA or signing of the Contract, whichever is earlier. |
| Intended Date of Completion | 6.15 | The intended completion date for the whole construction works in 09 (nine) months or yyyyyy Months after start of work |
| Additional Documents that also form part of contract | | <ol style="list-style-type: none"> 1. Work Program 2. Methodology 3. Planned Value Statement 4. Environment Management Plan 5. Major items of Construction Equipment 6. Qualification and Experience of Key Personnel 7. Evidence of access to financial resources 8. Name, Address, E-mail ID, Telephone no of Contractors Bankers 9. Proposed Subcontractors <p>All to be submitted as part of the Contract Agreement.</p> |

RFP for Development of three Child and Family-friendly junctions and 1.5km Connected shared Street at Saheli Marg and Big Bazar Rd, Udaipur, Rajasthan

| | | | | | |
|---|---------|---|---|---|--|
| Payment Schedule | 6.25.9 | The Payment Schedule shall be submitted by contractor after issue of LoA and before signing of agreement which will be approved by the Engineer-in-Charge after discussions and mutual consent. | | | |
| The law which applies to the Contract | 6.3 | The Laws of the State of Rajasthan, India | | | |
| The Language of the Contract Documents | 6.3 | English | | | |
| | | ITEM | Amount to be insured | Deductibles | |
| Amounts of Insurance & Deduction by Engineer-in-charge in case of failure on part of Contractor to get the insurance policies | 6.11 | A | Loss of or damage to the works, plants and materials | 5.0% of contract value | Deductibles for insurance shall be as per latest tariff of General Insurance Company of India plus 20% of premium amount for items A, B C & D. |
| | | B | Loss of or damage to equipment | 2.5% of contract value | |
| | | C | Loss of or damage to property (except works, plant, material and equipment) in connection with the contract | 1.0% of contract value | |
| | | D | Personal injury or death | Rs. 1 lac per occurrences for maximum three Occurrences | |
| The Period of Submission of the Work Program for approval by Engineer-in charge (ITB) | 4.4.3 | <ol style="list-style-type: none"> 1. fourteen (14) days from the issue of Letter of Award 2. The updated program shall be submitted at interval of one month. 3. The Penalty for late Submission of an updated program shall be 0.01 % of contract price for each 4. interval of one month or a part thereof | | | |
| Variation | 6.25.3 | Applicable As per clause 6.25.3 | | | |
| Payment for running bills | 6.25.9 | Running Bills Payment shall be released monthly as per actual completed work, based on the agreed schedule. The amount of payment of running bills shall not be less than ₹..... | | | |
| Taxes | 6.25.11 | The rates quoted by the Contractor shall be deemed to be inclusive of the GST as per prevailing rates, Royalty, Income Tax, Service Tax, Labour CESS and all other statutory taxes | | | |

RFP for Development of three Child and Family-friendly junctions and 1.5km Connected shared Street at Saheli Marg and Big Bazar Rd, Udaipur, Rajasthan

| | | |
|--|----------------|--|
| The currency of the Contract(ITB) | 4.14 | Indian Rupees |
| The formula (e) for adjustment of prices | 6.25.13 | No Price Adjustment is applicable in this Contract |
| Retention money | 6.25.14 | 5% of each payment will be withheld as retention money from every payment made to the contractor. 50% of the Retention money shall be released after completion of work & issue of completion certificate. Balance 50% of the Retention money shall be released at the end of DLP & issue of performance certificate. |
| Delay Damages | 6.25.15 | Delay damages per week shall be 0.05% per day of the Contract Price subject to the maximum of 10% of Contract Price. |
| Escrow Account | 6.1.31 | Not Applicable. |
| Advance Payment/ Mobilization advance | 6.25.16 | Mobilization advance/Advance payment amount shall be equal to 10% of the Contract value, which shall be released on receipt of BG from Nationalized Bank equal to 110% of the value of Advance Payment Amount/ Mobilization Advance. Recovery of Advance payment shall be made from payment certificate based on the percentage of Works completed, Recovery shall be completed in the payment certificate before the final certificate. The mobilization advance/ advance payment shall be released to the contractor as per following conditions: 1. 5.0% of Contact Cost after signing of Contract Agreement and submission of BG from Nationalised Bank. 2. 5.0% of Contract Cost after mobilization of men and Machinery as per contract at site, establishment of site office. The interest on advance payments shall be charged by the Employer as per the Prime Lending Rate RBI interest rates at the time of Signing of Contract Agreement. |
| Performance Security | 6.25.18 | The Performance Security shall be 10% of the accepted Contract Price |
| | | In case, the bid is unbalanced the additional BG shall be applicable as per clause (4.30) of ITB Section-3. The Contractor shall submit the Performance security within 07 days of receiving the Letter of Award. Performance Security shall be valid for 60 days beyond the Defect Liability Period and shall be released thereafter. Additional Performance Security (4.30) shall be released after the physical completion of the project and issuance of completion certificate. |
| Operation & Maintenance Period | 6.26.3 | 05 Years (shall start after the end of the completion date) |
| If "As Built drawings required | 6.26.4 | Yes |

RFP for Development of three Child and Family-friendly junctions and 1.5km Connected shared Street at Saheli Marg and Big Bazar Rd, Udaipur, Rajasthan

| | | |
|---|----------|--|
| The date by which "As Built drawings are required | 6.26.4 | As built drawings of the works completed against which final payment is claimed, shall be submitted together with final payment claim as evidence of completion of work. |
| Format for delivery of "As Built drawings | 6.26.4 | In two sets of Print in required size and softcopy in Pen Drive. |
| The amount to be withheld for failing to supply "As Built" drawings, if any, by the date required | 6.26.4 | 01% (one percent) of the Contract amount, whichever is higher |
| O&M manuals | 6.26.4.1 | O&M manuals as per requirement for electrical equipment and machinery shall be submitted by the Contractor within 30 (thirty) days after completion of Works |
| Dispute Resolution Mechanism | 6.27.8 | As mentioned in Section 6 Conditions of Contract. |
| The percentage to apply to the value of the work not completed representing the Employers' additional cost for completing the works | 6.26.6.1 | Shall be 20.0% of bill amount of the balance cost of work |

RFP for Development of three Child and Family-friendly junctions and 1.5km Connected shared Street at Saheli Marg and Big Bazar Rd, Udaipur, Rajasthan

SECTION 8: SCOPE OF WORK

8.1 Project Site

Saheliyon Ki Bari is an important destination in the northern part of Udaipur city. It is connected to the UIT circle in the south and the Sukhadia Circle junction to its east via Saheli Marg. It links city-level public places and tourist destinations like Saheliyon ki Bari, Fatehsagar Pal, Maharana Pratap Smarak, Sukhadia Garden and parks. (See Figure below)



Saheliyon ki Bari as anchor institution

Saheliyon ki Bari is a major garden and ITC destination of Udaipur abutting Saheli Marg. Therefore, Saheliyon Ki Bari has been selected as the anchor institution for the assessment of the site area and a radii of 600m from the Triangular Junction at the center of Saheli Marg, has been taken as the study area. (See Figure above)



Caregivers with toddlers heading towards Saheliyon ki Bari at Saheli Marg Junction

RFP for Development of three Child and Family-friendly junctions and 1.5km Connected shared Street at Saheli Marg and Big Bazar Rd, Udaipur, Rajasthan

8.2 Site Characteristics

Saheli Marg from Saheliyon Ki Bari upto Sukhadia Circle, located in Ward number 3, is the central spine abutting major residential and recreational areas. It is connected to important public places of interest and ITC destinations for example play schools, parks, gardens, and childcare health centre. (See Figure 9)

Saheli Marg is an important movement corridor for pedestrians and vehicular traffic which is used by ITCs to reach their destinations. Sukhadia Circle is connected through internal roads to Saheli Marg within a walkable distance. UIT circle and Saheli Marg triangular junction lie along the Saheli Marg road, to the south. These nodes are major crossing points for people destined to Saheliyon ki bari, Fateh Sagar Pal and surrounding residential areas. It is to be noted here that no primary healthcare or anganwadi centre abuts the Saheli Marg.

Following are the parts of the site (Refer Figure 9 Below)-

1. 1.5Km connected shared street comprises of-
 - a. Saheli Marg starting from Fateh pura Police Chowki Junction at the North upto UIT Circle towards south
 - b. Big Bazaar Road from Triangular Junction upto Sukhadia Circle Junction
2. Three Family Friendly Junctions-
 - a. Saheli Junction at Saheliyon Ki Bari entrance
 - b. Triangular Junction at Saheli Marg
 - c. Sukhadia Junction

All parts of the site mentioned above are proposed to be taken up for redevelopment to include ITC and family related facilities. The stretch of Saheli Marg from Saheli Junction to Triangular Junction is proposed to be taken up for Tactical Intervention to test the proposed ITC related transformation.

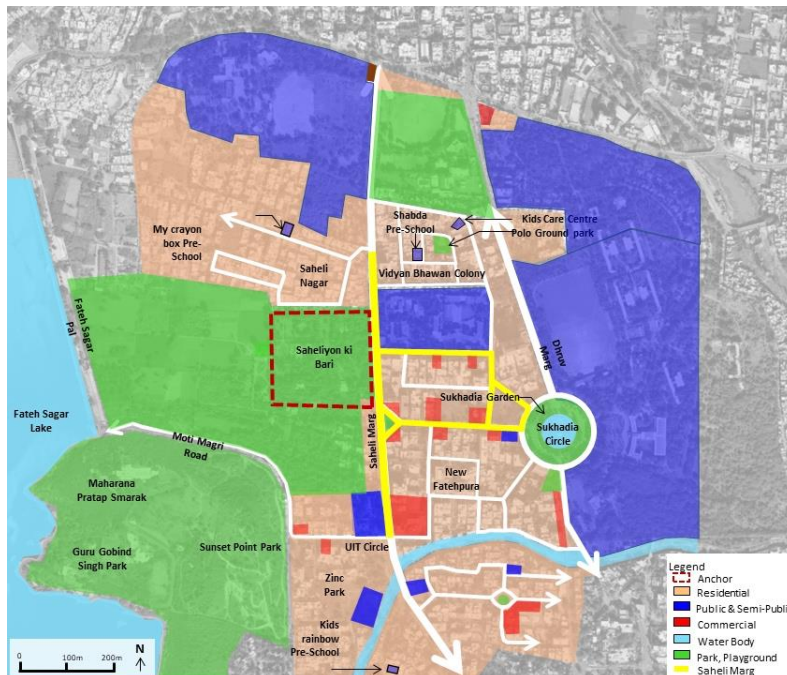

Context of study area

8.3 Project Objectives

The objectives of this project are-

1. The Urban Built Environment has a direct impact on children's safety. An unsafe environment in and around ITC facilities can increase the likelihood of accidents and injury, which can have physical as well as psychological implications for the child.

RFP for Development of three Child and Family-friendly junctions and 1.5km Connected shared Street at Saheli Marg and Big Bazar Rd, Udaipur, Rajasthan

Therefore, it is imperative to have a model case that can provide a safe built environment for young children in cities.

2. To Develop connected shared street including child and family friendly junctions in Udaipur which facilitates young children and their caregivers.
3. This facility will be planned along an important collector road of the city and will disseminate the idea of streets as public spaces with dedicated walking space, cycling space, pause points and children play area, a better journey experience and traffic calming measures which motivates caregivers to walk or cycle with their young children.

8.4 PROJECT DESIGN ELEMENTS & COMPONENTS

| S/n | Particular |
|-----|--|
| 1 | Benches with planters made out of brick and stone with native plant species |
| 2 | Table top crossing and raised junctions |
| 3 | Traffic signage to be installed on existing light poles |
| 4 | Way finding signage |
| 5 | Excavation, levelling etc. |
| 6 | Aesthetically appealing floor and wall art |
| 7 | Installation of Breast Feeding booths |
| 8 | Installation of bollards |
| 9 | Installation of seating bollards |
| 10 | Installation of bamboo Jafri around transformers and painting it in fire retardant paint |
| 11 | Fixing of existing footpaths and construction of new footpaths. |
| 12 | Construction of kerb ramps for footpaths |
| 13 | Painting of cycle tracks either on existing paver blocks or blacktop surfaces, including painting of cycle track symbols |
| 14 | Construction of median refuge with bollards |
| 15 | Painting of Lane Marking, stop sign, arrow marking etc in thermoplastic paint |
| 16 | Construction of mound at the proposed resting zone near Sukhadiya Circle |
| 18 | Construction/ repair of covers of existing storm water drains, including paving. |
| 19 | Construction of pergolas for shade. It is proposed to be made out of MS and wood including fire retardant paint |
| 20 | Plantation of trees and shrubs of local variety |
| 21 | Doob grass plantation |
| 22 | Procurement and installation of bicycle parking stands. |

8.4.1 Site cleaning

The site is mostly clean, except the near Sukhadiya Circle, where the drains are clogged, and garbage is being dumped in the open. Even along the Big Bazar road, at some points garbage is being dumped in the open. These would have to be cleaned before start of the work.

8.4.2 Integration of proposals from this DPR with the on-going works

The on-going works of laying Storm water Drains and Grasscrete edges of carriageway along

RFP for Development of three Child and Family-friendly junctions and 1.5km Connected shared Street at Saheli Marg and Big Bazar Rd, Udaipur, Rajasthan

Saheli Marg will have to take into consideration the recommendations of this DPR. Especially the **construction of tabletop crossings and installing of bollards along proposed cycle track** will have to be taken up along with ongoing works.

8.4.3 Drain maintenance

Big Bazar Road has storm water drains running on both of their sides. These drains are not maintained and have debris, garbage and tree litter filled in them that clog the drains near Sukhadia Circle and make it a breeding spot for mosquitoes. The first step here would be **unclogging these drains, repair the damaged parts of these drains with plastering wherever required and checking their existing slope**, and if required, fixing them.



Portion of Storm water drain near Sukhadiya Circle

8.4.4 Drain covering

The next step would be to cover these drains with Kota Stone slabs as drain **covers supported by MS T sections underneath**. The Ferro concrete drain covers are not recommended as these increase the height of the footpaths to 300mm making them inaccessible. This would allow the water to pass through the drains and keep it clear from the garbage and debris falling into it. These drain covers can be removed for maintenance.

Along Saheli Marg, at most places Ferro Cement Concrete covers have already been installed making the footpath 300mm high. To make the footpaths accessible with minimum changes, the **detail of the cover of Storm Water Drains at the location of table tops** will have to be changed. Instead of 150mm thk concrete covers, 35mm thk kota stone slabs with metal T sections underneath may be provided.

RFP for Development of three Child and Family-friendly junctions and 1.5km Connected shared Street at Saheli Marg and Big Bazar Rd, Udaipur, Rajasthan



150mm thk drain cover makes footpath inaccessible

8.4.5 Sidewalks and Cycle Tracks

Along Saheli Marg, the sideways are already constructed and the the same cannot be changed. The 1.75m wide stretch of Grasscrete surface from Fatehpura Police Chowki Junction upto UIT circle is proposed to be used as a cycle track.

Along Big Bazar Road, new Footpath and cycle track is proposed along LHS from Circular roundabout to Sukhadiya Circle. On the opposite side the existing footpath is to be made continuous. **These sidewalks would be make with cement concrete paver blocks on the top and kerb stones on the edge. It would be at a height of 150mm form the street level.** These sidewalks would be ITC friendly with colourful **paver blocks and floor games pattern painted on them**, making them visually appealing for young children and safe for the pedestrians.

Artistic paintings in the form of way finders towards Saheliyon Ki Bari and Sukhadiya circle would also be painted on these sidewalks. This would help the caregivers and young children to identify their way towards these destinations, while engaging and creating a cognitive development activity.

RFP for Development of three Child and Family-friendly junctions and 1.5km Connected shared Street at Saheli Marg and Big Bazar Rd, Udaipur, Rajasthan



Sidewalk games

| | Width (Min.) |
|----------------------------------|---------------------|
| A. Dead Width | 500 mm |
| B. Footpath (Clear Space) | 1800 mm |
| C. MUZ Zone (Sidewalk Play Area) | 1800 mm |



Extended ramps and on street parking encroaching the walking space for pedestrians

Large Number of properties along Big Bazar Road have constructed illegal ramps to access their properties on the road space compromising the space for footpath. These ramps would have to be broken to provide continuous footpaths. These ramps are not too steep for safe and comfortable pedestrian movement.

RFP for Development of three Child and Family-friendly junctions and 1.5km Connected shared Street at Saheli Marg and Big Bazar Rd, Udaipur, Rajasthan

8.4.6 Street Markings

All junctions and streets in the project area require demarcation and dedicated zones for pedestrian and vehicular markings, that depict the upcoming turns for the next lane and makes the streets safer for the pedestrians. **These street markings would indicate an incoming vehicle about the turns that street has, allowing it to slow down before the turn arrives, making the chances of an accident low.**

These markings would include arrows on street painted with thermoplastic paint that makes it permanent and visible from far.

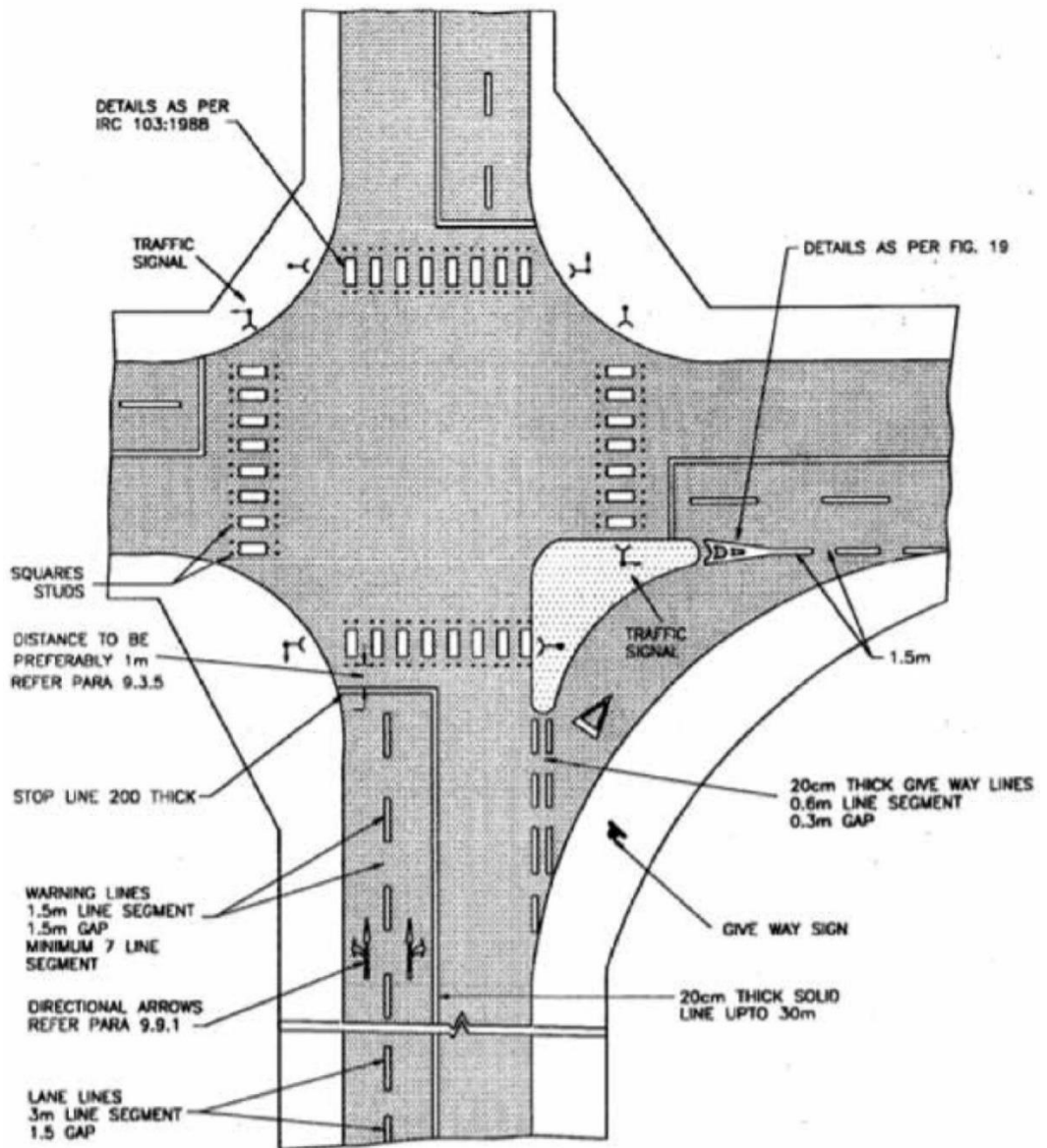

Source: Guidelines for Road Markings (UTTPEEC) and Code of Practice for Road Markings (IRC:35-1997)

Road markings. Source: (IRC:35, 1997)

RFP for Development of three Child and Family-friendly junctions and 1.5km Connected shared Street at Saheli Marg and Big Bazar Rd, Udaipur, Rajasthan

8.4.7 Traffic calming elements

All junctions and streets in the project area require traffic calming elements to make the streets ITC friendly. **These traffic calming elements would make the vehicle slow down before approaching nodes and various ITC destinations.** For this, various types of traffic calming elements would be used such as - **rumble strips, zebra crossings, tabletops, road signages and reflector signages.**

1. **Rumble strips** – 5 of these rumble strips of thermoplastic paint with 7mm thickness would be painted before each pedestrian crossing/ STOP sign, making the vehicle slow down before approaching these by creating friction with the strips.

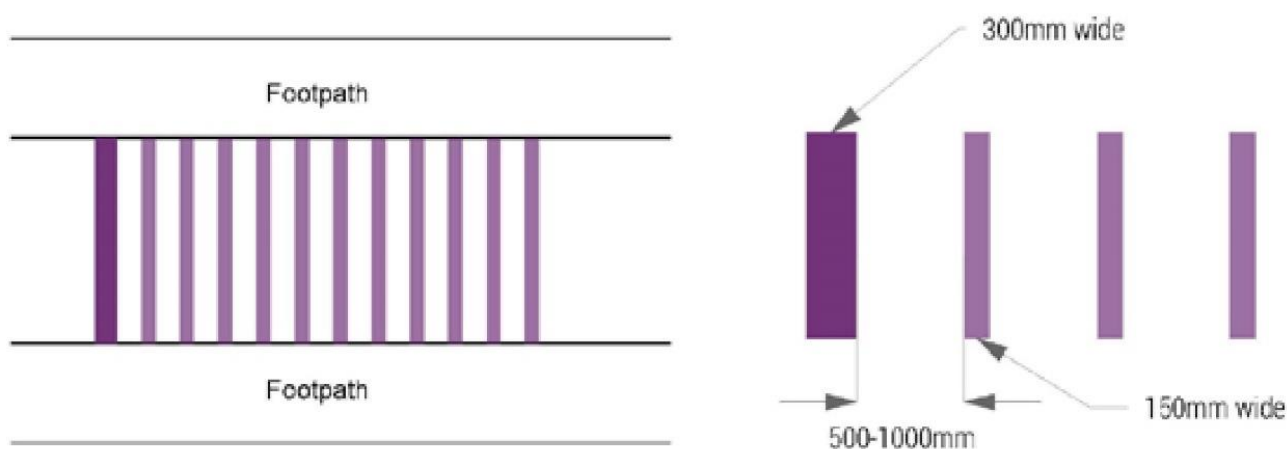

Note

The raised rumble strip markings using thermo plastic paint or mastic sheets can be used with installation across the carriageway for deliberate reduction of speed for child friendly design in urban areas. The first application can be of 300 mm wide strips and second can be of 150 mm. These strips shall be provided at 500 mm to 1000 mm spacing's in a series / set comprising 15 to 20 strips at the distance of 130 m to 180 m from the start of the crossing point, for both directions of traffic.

7mm thermoplastic rumble strips. Source: (IRC:55, 2014)

RFP for Development of three Child and Family-friendly junctions and 1.5km Connected shared Street at Saheli Marg and Big Bazar Rd, Udaipur, Rajasthan

- Zebra crossings** – Zebra crossings would be painted on each pedestrian crossing after the rumble strips to give the pedestrians a safe crossing path and installing a habit to use zebra crossings while crossing streets and roads.

Note

The width of the pedestrian crossing is governed by the pedestrian volumes crossing the road and by local requirements but in no case should it be less than the width of footpath subject to a minimum of 1.5 m. The width of the crossing generally lies between 2 m and 4 m. Marking for pedestrian crossing mostly used is the Zebra pattern consisting of equally spaced white stripes generally 500 mm wide should be marked. A warning sign to indicate that the pedestrian crossing is ahead should also be installed.

A mid-block pedestrian crossing in urban areas, may be advantageous to install flashing signals along with the markings, so that the drivers receive advance warning about the presence of the crossing.

Source: *Guidelines for Road Markings (UTTIPEC)* and *Code of Practice for Road Markings (IRC:35-1997)*

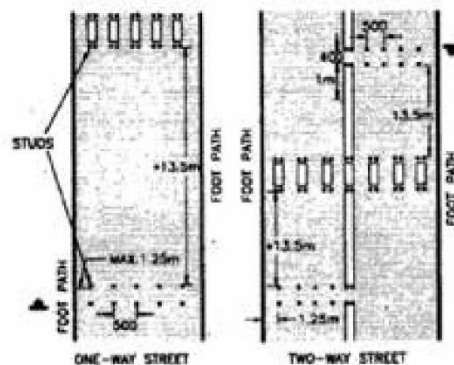
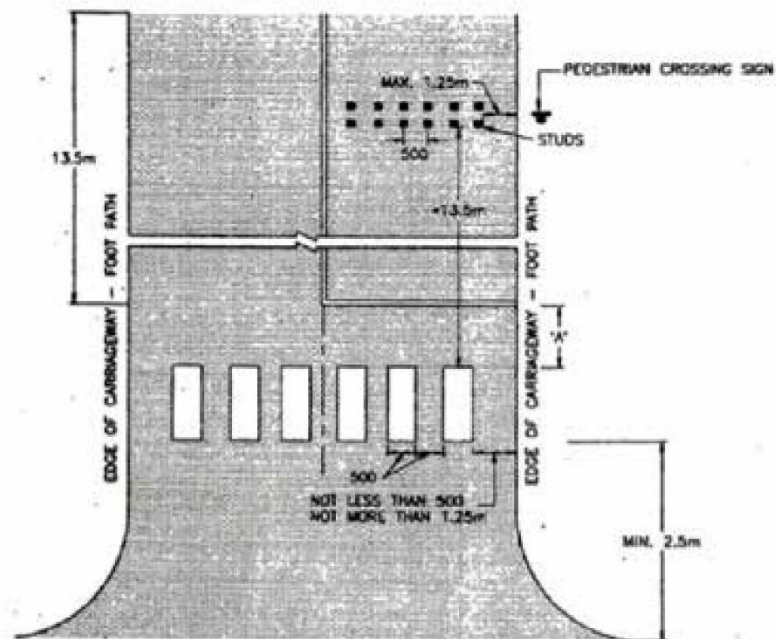

Zebra crossing for safer movement across the street. Source: (IRC:35, 1997))

RFP for Development of three Child and Family-friendly junctions and 1.5km Connected shared Street at Saheli Marg and Big Bazar Rd, Udaipur, Rajasthan

3. **Bicycle crossing** – Painted bicycle track crossing would be provided along with Zebra Crossings.



Painted cycle track with bollards for safety. Source: (www.jagran.com, 2022)

4. **Tabletops**—Along Saheliyon Ki Bari, footpaths have already been constructed at a height of 300m. As such, and to provide universal accessibility, only tabletop crossings are feasible. As such, all crossings along Saheli Marg are recommended to be tabletops.

RFP for Development of three Child and Family-friendly junctions and 1.5km Connected shared Street at Saheli Marg and Big Bazar Rd, Udaipur, Rajasthan



Tabletop crossing

5. **Road signages and reflector signages** – Road signages and reflector signages would be installed at key junctions and nodes, as well as near the ITC destinations and ITC play areas to create awareness as well as creating a cautionary notification about these spaces where the incoming traffic should take extra care while driving. Signages depicting Child friendly zones, ITC destinations, Slow down signs, Zebra crossing ahead signs and speed limit signs would be installed throughout the neighbourhood.

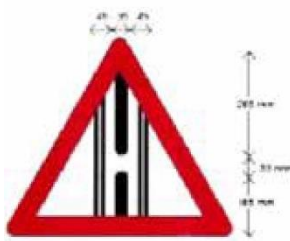

Fig. 15.32 Gap in Median

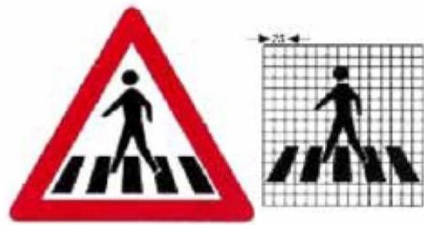

Fig. 15.33 Pedestrian Crossing

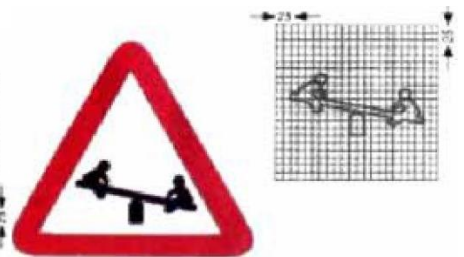

Fig. 15.58 Playground Ahead



Fig. 14.52 Compulsory Cycle Track/Cycle Only



Fig. 14.54 Pedestrian Only

Street signages. Source: (IRC:35, 1997)

RFP for Development of three Child and Family-friendly junctions and 1.5km Connected shared Street at Saheli Marg and Big Bazar Rd, Udaipur, Rajasthan

8.4.8 Installing ITC friendly furniture

The streets and junctions in the project area requires ITC friendly furniture. Furniture like ITC friendly benches and cycle stands are required along the street and at junctions. **This would help change the walking and cycling experience of the streets and junctions and make it more efficient for the caregivers to use footpaths and cycletracks on a regular basis.**

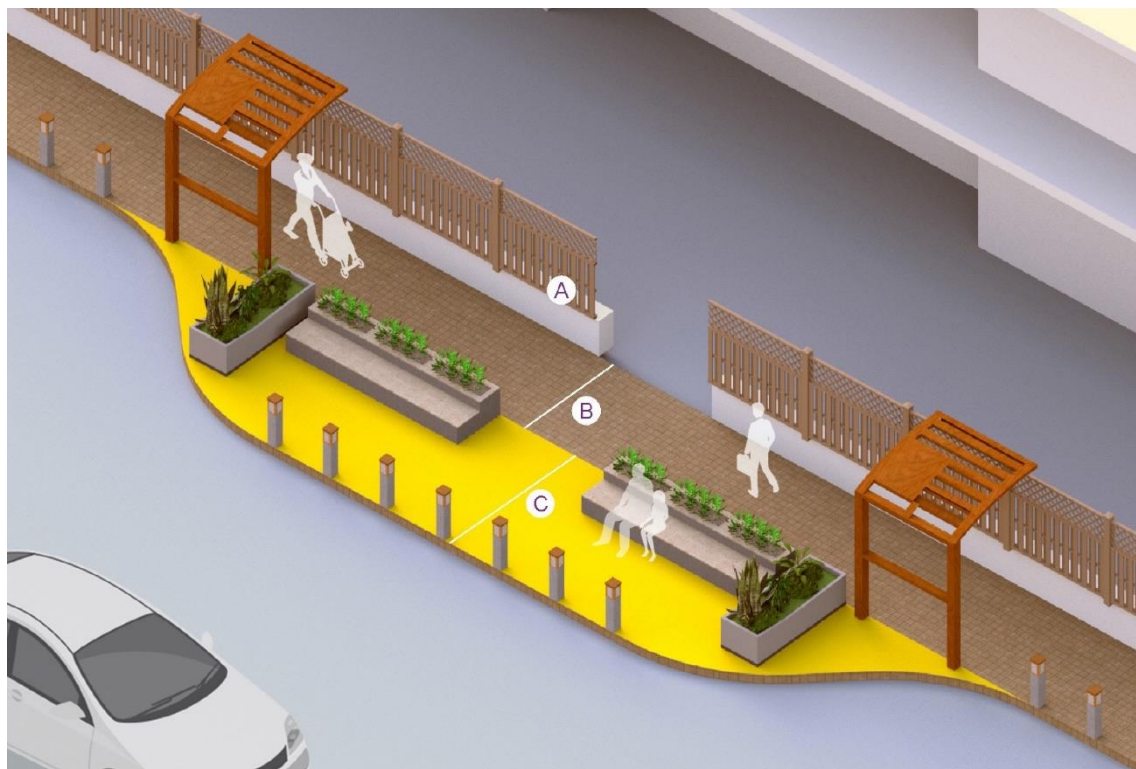

ITC friendly furniture

| | Width (Min.) |
|----------------------------|--------------|
| A. Dead Width | 500 mm |
| B. Footpath (Clear Space) | 1800 mm |
| C. MUZ Zone (Waiting Area) | 1800 mm |

8.4.9 Creating ITC friendly zones at the junctions

The identified junctions within the project area provide opportunity for different kind of activities and engagement for ITC.

- Fatehpura Police Chowki junction** is an important entry to the Saheli Marg. However, the junction itself does not have any destination for ITC. As such, this junction has been provided with facilities for all age groups. Space for resting and taking a pause while walking or cycling have been provided near the police station. In addition to it, the junction geometry have been improved to make it safer for all users including ITC. Provision for crossing, traffic calming and universal accessibility have also been provided.
- Saheliyon Ki bari Junction** is an important destination for ITC. Surveys reflect that the junction and precinct receives high footfall of ITC either destined to Saheliyon ki Bari or coming out of it. As such, space for active and passive recreation have been provided at the junction in addition to the provision of crossing, universal accessibility, traffic calming, vending zones, etc. This would help in their Early Childhood Development, the Saheliyon Ki Bari entry has been provided space that is specifically dedicated to the children of age 0-5 years, with

RFP for Development of three Child and Family-friendly junctions and 1.5km Connected shared Street at Saheli Marg and Big Bazar Rd, Udaipur, Rajasthan

dedicated play equipment and an interactive zone with floor painted patten where these young children can play and learn.

3. **The Semi-Circular Junction** of Saheil Marg and Big Bazar Road has been improved with landscaping and seating spaces. It is proposed to create a vending zone parallel to the Saheli Marg abutting this island where some of the vendors from Saheliyon Ki Bari can be rehabilitated.
4. **UIT Circle Junction** has recently been improved. Moreover it does not have any destination for ITC. The surveys showed large number of cyclists passing through this junction in the morning hours, comprising of various age, income and gender groups. As such, only crossing facilities, traffic calming, seating space etc. being proposed to make this junction a viable pause point for cyclists and pedestrians.
5. **Sukhadiya Circle Junction** where the Big Bazar road comes and meet is being designed with suitable crossing, traffic calming facility. At the entry of the green area an ITC friendly resting area is being proposed.

8.4.10 ITC friendly furniture along the shared street and the junctions

The shared street and the junctions require ITC friendly furniture along footpaths and kerb extensions. Furniture like ITC friendly benches are essential for caregivers to sit in a range where they feel secure for their child as well as are also comfortable spending time while walking, cycling or taking a pause.



ITC friendly furniture with planters

RFP for Development of three Child and Family-friendly junctions and 1.5km Connected shared Street at Saheli Marg and Big Bazar Rd, Udaipur, Rajasthan

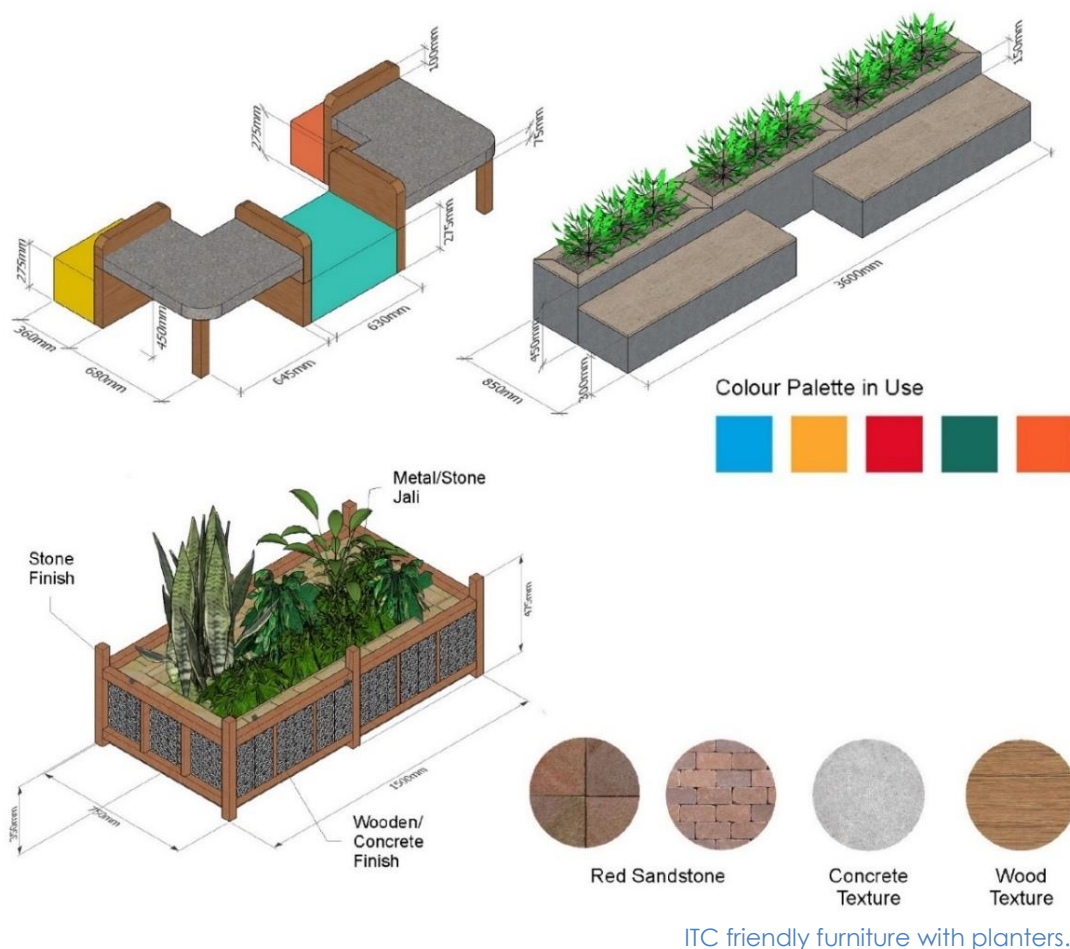

8.4.11 Addition and maintenance of the plantation around the anchor institute

The existing plantation along the street and junctions are well maintained by the respective agencies. However, regular pruning, providing tree gratings for both preserving the earth base of the tree roots and provide even surface for walking and cycling is essential. More potted plants are proposed along the footpaths and junctions to bring nature within close proximity of ITC's walking and resting experience. Maintenance in terms of trimming the overgrown plants and removing of weeds from the plants and grasses are required. Regular watering is also included in this.

RFP for Development of three Child and Family-friendly junctions and 1.5km Connected shared Street at Saheli Marg and Big Bazar Rd, Udaipur, Rajasthan

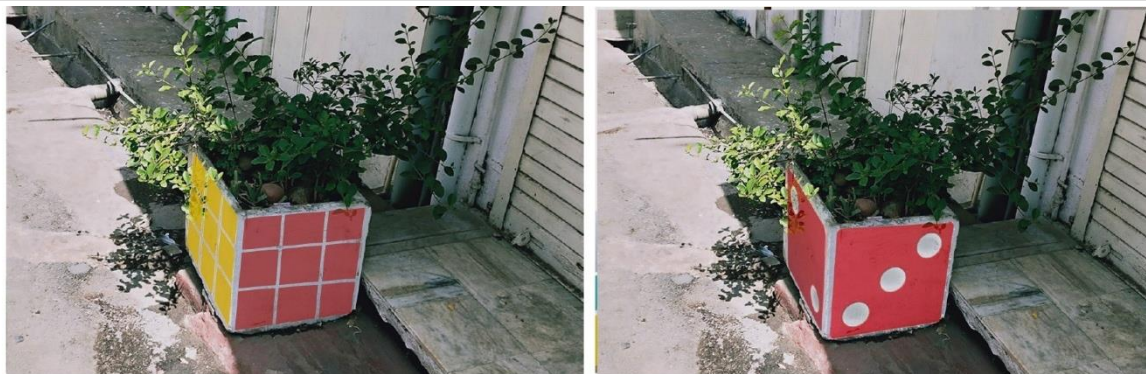

Source: Planter Near Vidya Bhawan School

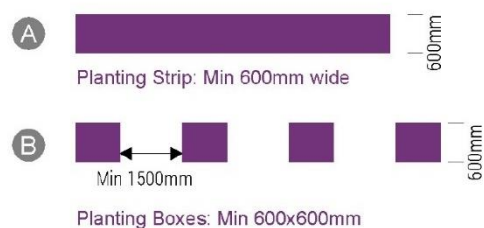

Planters.

8.4.12 Repairing and beautifying the dead boundary walls

Most part of the shared street and the junctions either have active frontage, private boundary walls or murals on the walls. Some sections of boundary walls along Saheli Marg, Saheliyon Ki Bari and a section of Big Bazar road, on the opposite side of "I love Chappan Bhog, Kaner Bistro and Belgian Waffle Restaurants" has dead boundary walls. The property behind the wall is vacant with wild plantation. It is recommended that this section of the wall be plastered, and painted with ITC friendly wall art. Artistic paintings would be done on these walls with ECD paintings and informative graphics making the approach engaging, fun and attractive for ITC.

RFP for Development of three Child and Family-friendly junctions and 1.5km Connected shared Street at Saheli Marg and Big Bazar Rd, Udaipur, Rajasthan



Dead Boundary walls along Saheli Marg



Dead Boundary walls near Saheliyon Ki Bari.

RFP for Development of three Child and Family-friendly junctions and 1.5km Connected shared Street at Saheli Marg and Big Bazar Rd, Udaipur, Rajasthan

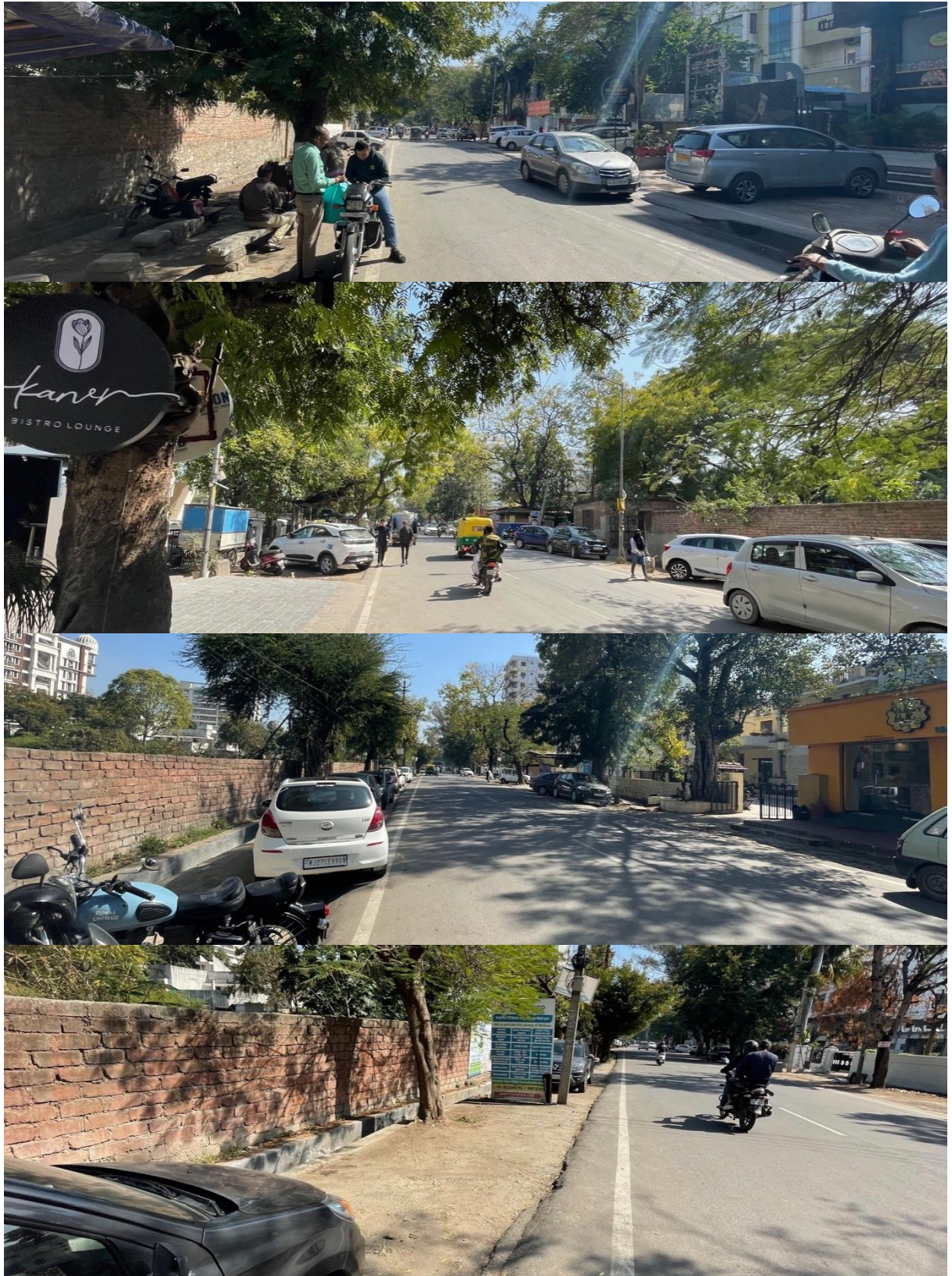

Sections of Dead Boundary walls along Big Bazar Road

RFP for Development of three Child and Family-friendly junctions and 1.5km Connected shared Street at Saheli Marg and Big Bazar Rd, Udaipur, Rajasthan

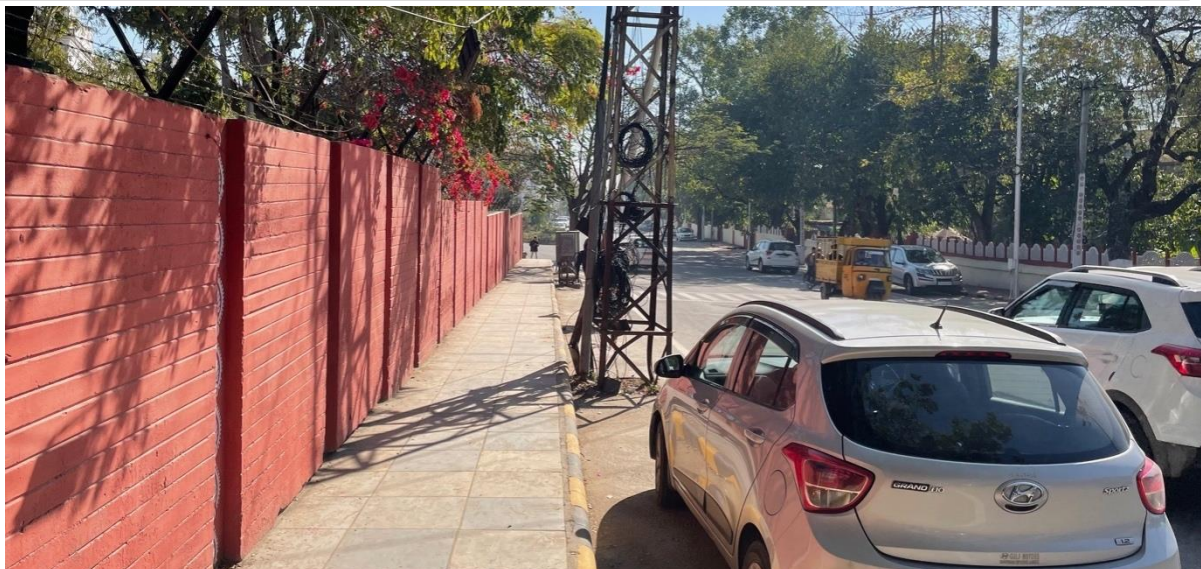

Existing dead boundary wall near Fatehpura Junction

8.4.13 Drinking water facility

A drinking water facility already exists on the road opposite to the Saheliyon Ki Bari Junction. The same has to be repaired, repainted and maintained.



Drinking water facility existing at Sahilyon Ki Bari Junction

8.4.14 Vending Zone at the Semi-Circular roundabout

The improved Semi-Circular Junction would continue to function as a landscaped zone with seating space and will now be connected with the vending zone through a small gate. This will make this island usable for people of all age groups and also reduce congestion at Saheliyon Ki Bari Junction due to ad hoc vending stalls.

RFP for Development of three Child and Family-friendly junctions and 1.5km Connected shared Street at Saheli Marg and Big Bazar Rd, Udaipur, Rajasthan



Improved Semi-Circular island, 2022)



Vending Zone area at Semi Circular Island.

8.4.15 Other Recommendations

To make the space inclusive and accessible, four-wheeler parking bays have been proposed at Saheli Marg Junction for cars with Differently Abled (Two Parking Bays), and cars driven by

RFP for Development of three Child and Family-friendly junctions and 1.5km Connected shared Street at Saheli Marg and Big Bazar Rd, Udaipur, Rajasthan

Single Women drivers (One Parking Bay) and Senior Citizens (One Parking Bay). This would also promote and encourage caregivers which need special assistance to access these areas.

- *Consideration should be given to the distribution of spaces for use by the Persons with Disabilities in accordance with the frequency and persistency of parking needs.*
- *Two accessible parking lot should be provided for every 25 car parking spaces.*

Source: Harmonised Guidelines and Space standards for Barrier Free Environment for Persons with Disabilities (Ministry of Urban Development, 2016)

RFP for Development of three Child and Family-friendly junctions and 1.5km Connected shared Street at Saheli Marg and Big Bazar Rd, Udaipur, Rajasthan

9.2 Proposal Elements with Reference Images

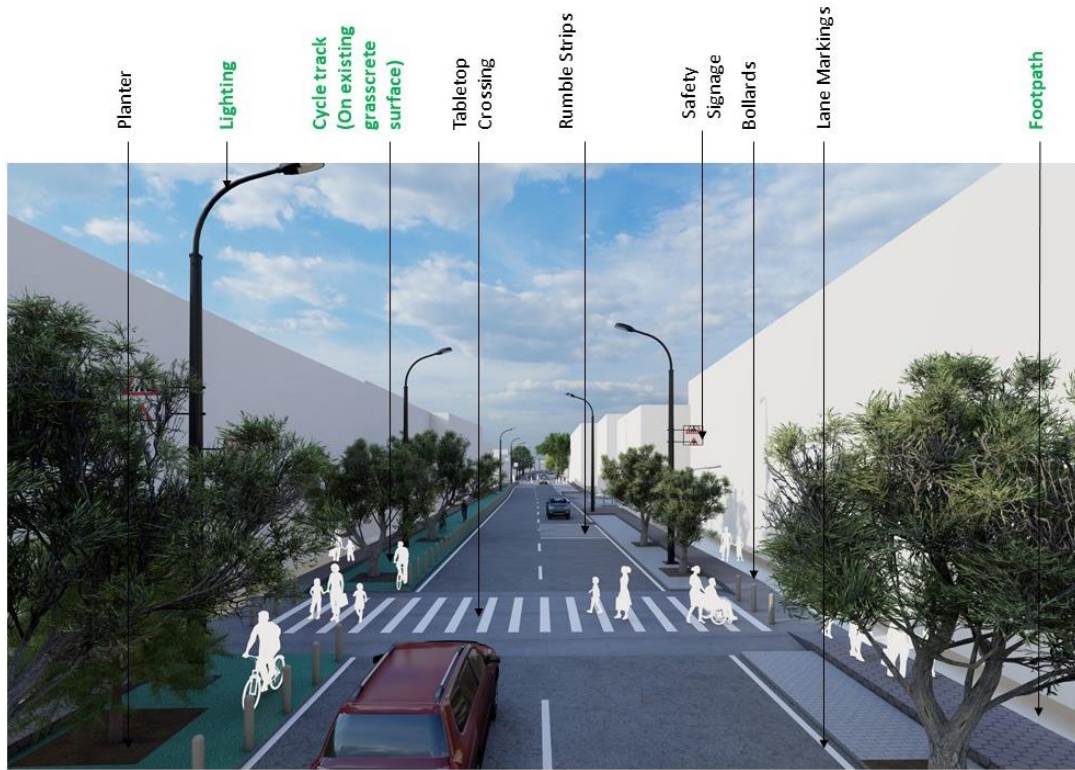

Design of Saheli Marg from Fatehpura Police Chowki to Saheliyon Ki Bari

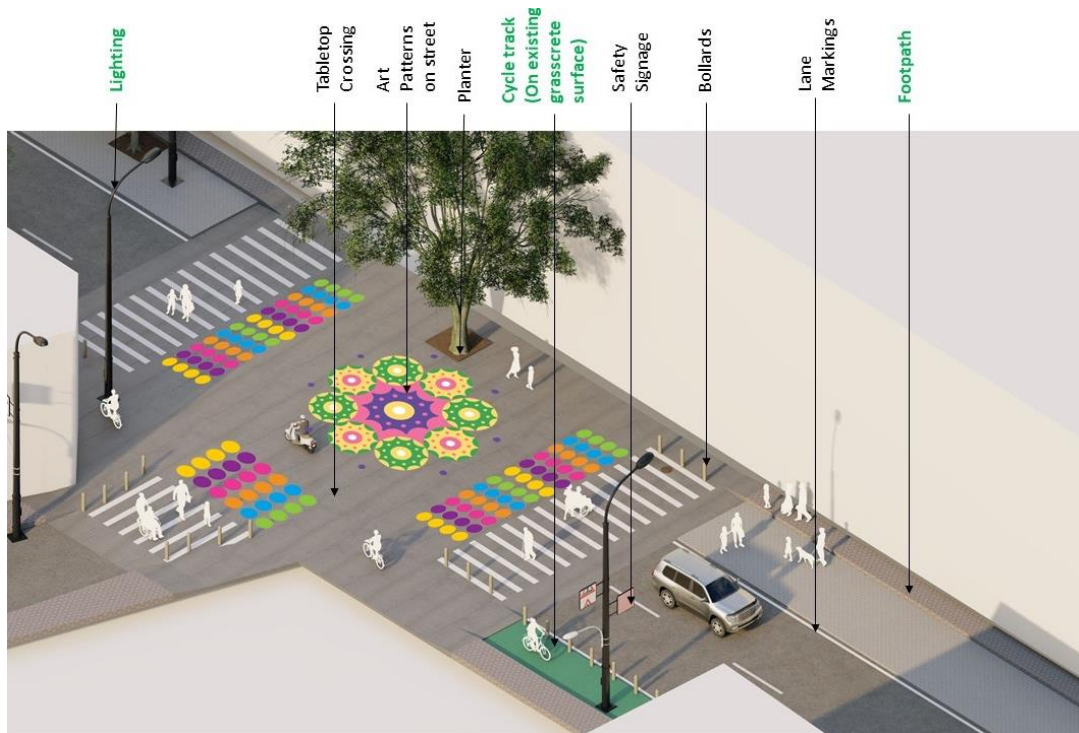

Design of Saheli Marg from Saheliyon Ki Bar upto Semi Circular roundabout

RFP for Development of three Child and Family-friendly junctions and 1.5km Connected shared Street at Saheli Marg and Big Bazar Rd, Udaipur, Rajasthan

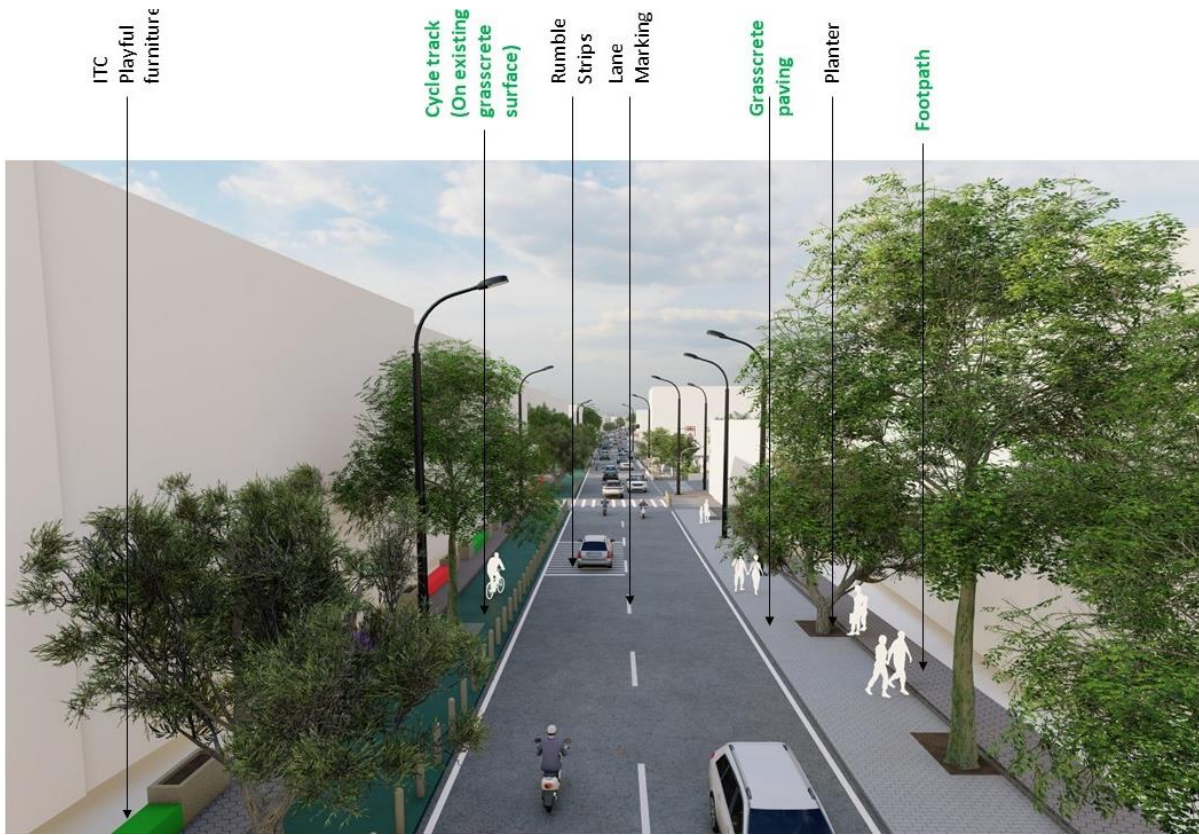

Design of Saheli Marg from Semi Circular roundabout upto UIT Circle

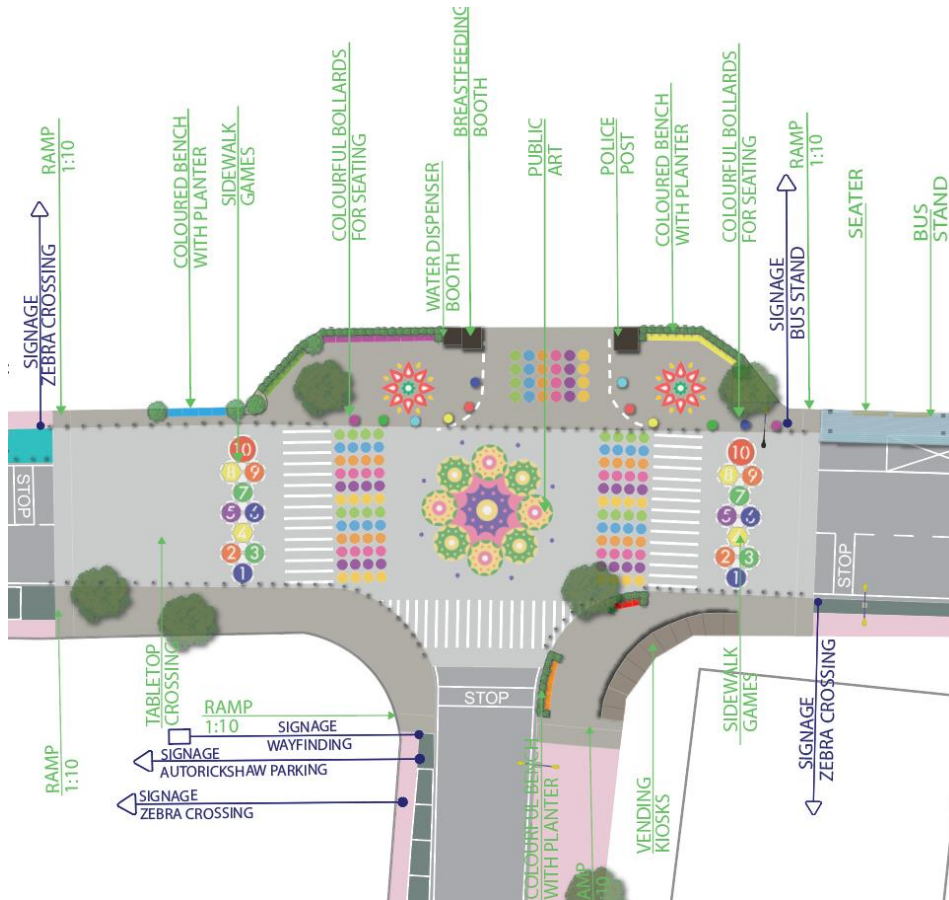

Design of Saheliyon ki Bari Junction

RFP for Development of three Child and Family-friendly junctions and 1.5km Connected shared Street at Saheli Marg and Big Bazar Rd, Udaipur, Rajasthan

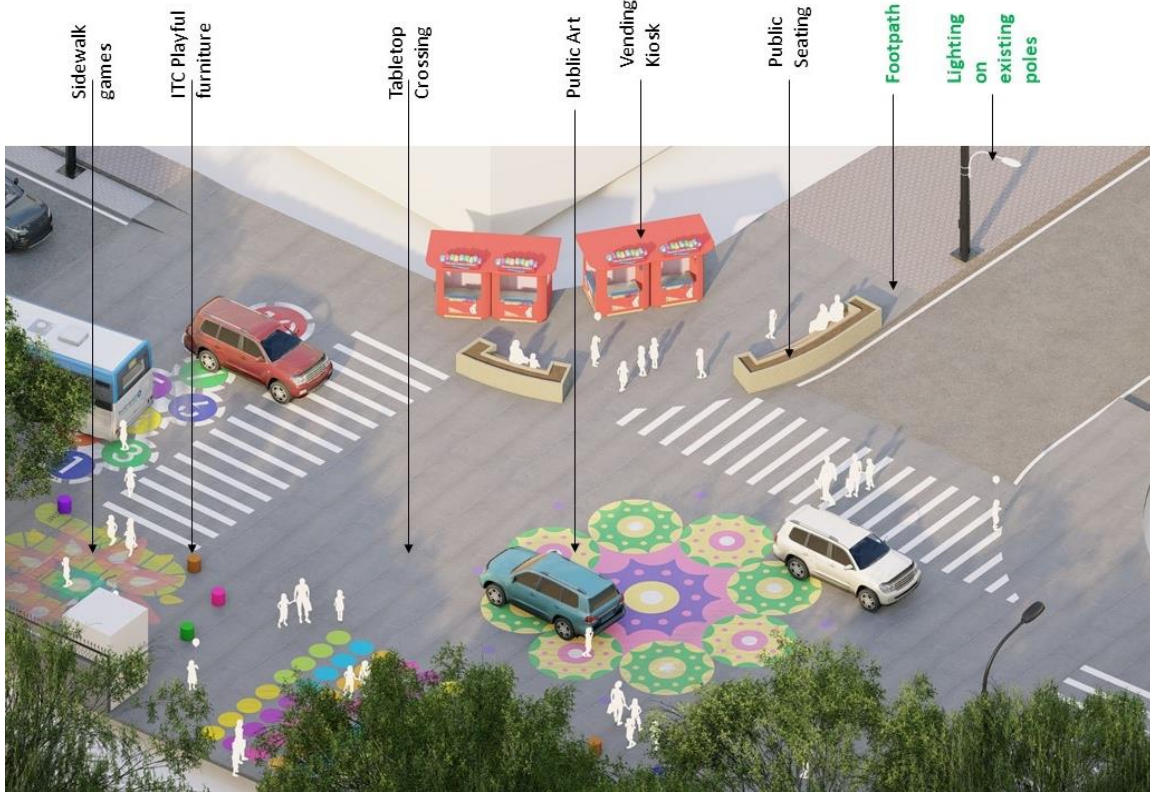

Design of Saheli Marg Junction

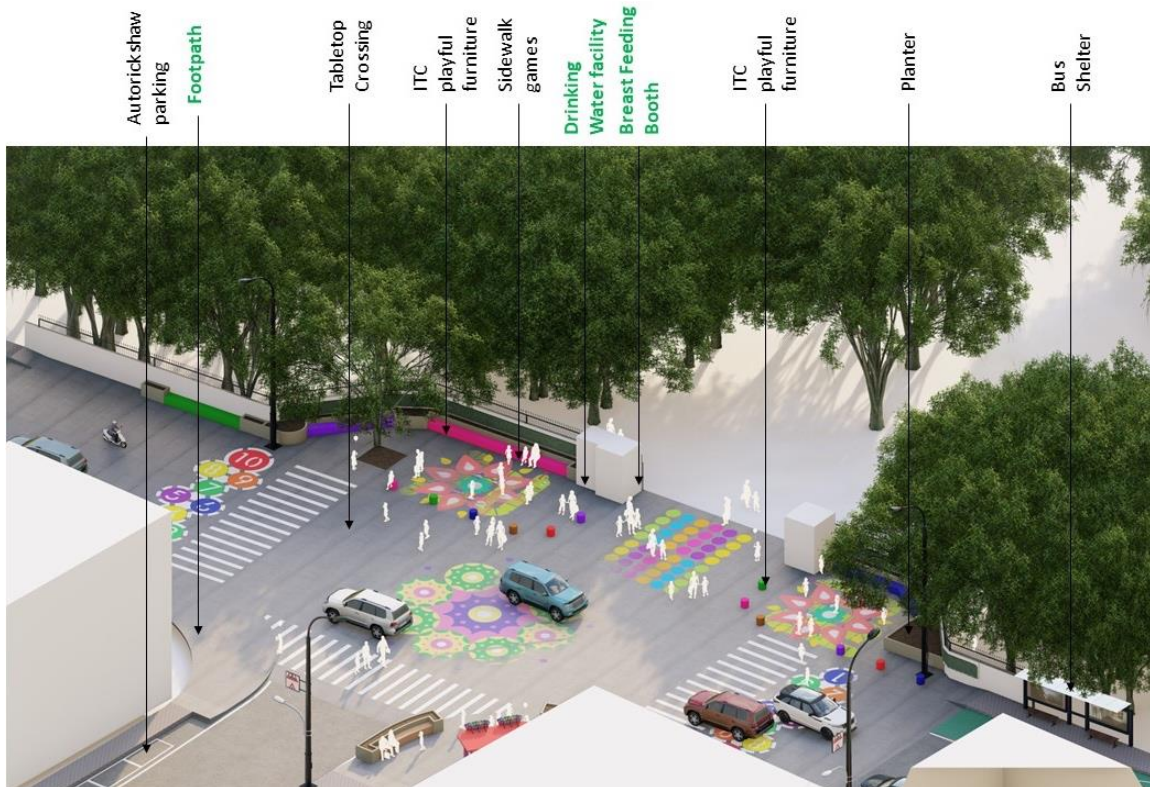

Design of Saheli Marg Junction at the entrance of Saheliyon Ki Bari

RFP for Development of three Child and Family-friendly junctions and 1.5km Connected shared Street at Saheli Marg and Big Bazar Rd, Udaipur, Rajasthan

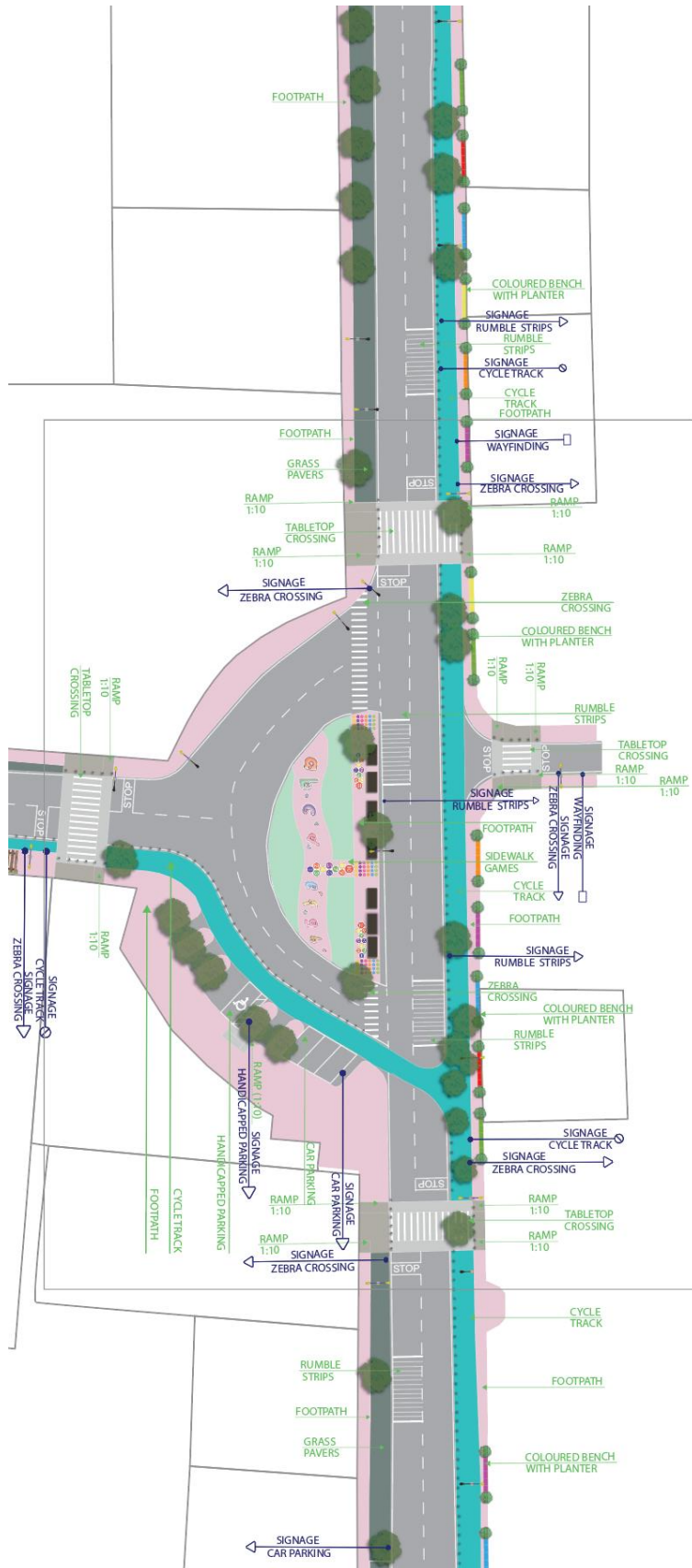

Design of Saheli Marg Semi Circular Junction

RFP for Development of three Child and Family-friendly junctions and 1.5km Connected shared Street at Saheli Marg and Big Bazar Rd, Udaipur, Rajasthan

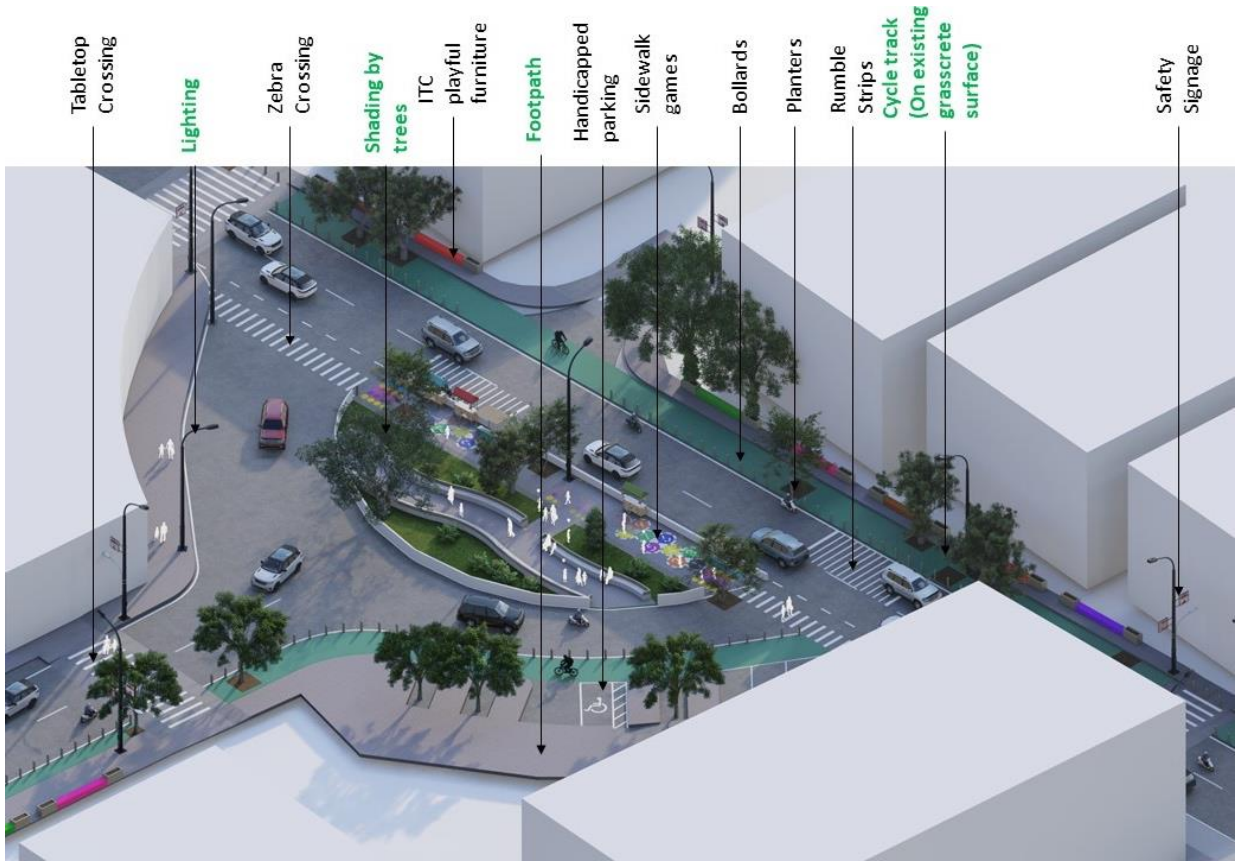

Design of Saheli Marg Triangular Junction

RFP for Development of three Child and Family-friendly junctions and 1.5km Connected shared Street at Saheli Marg and Big Bazar Rd, Udaipur, Rajasthan

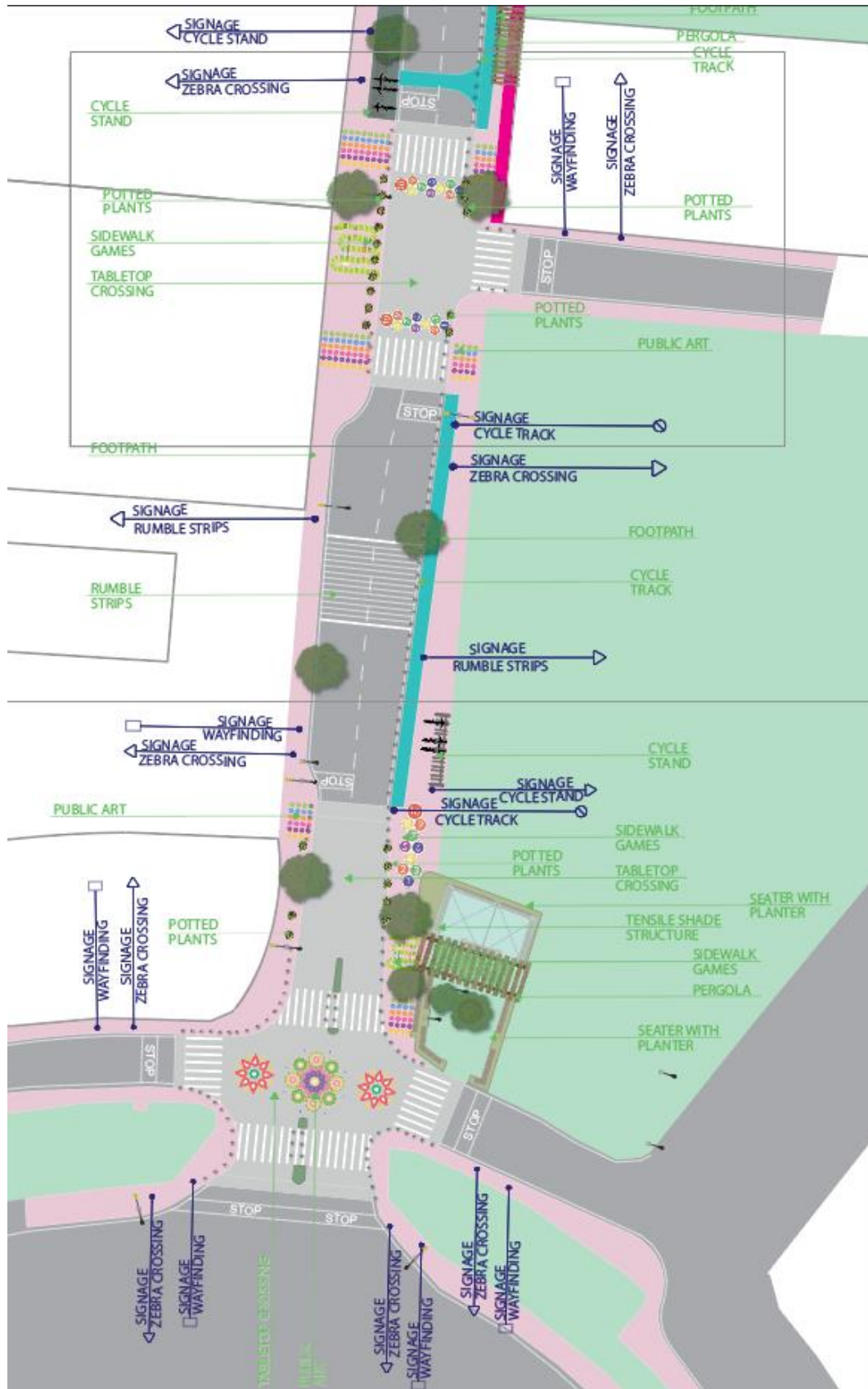

Design of Sukhadia Circle Junction

RFP for Development of three Child and Family-friendly junctions and 1.5km Connected shared Street at Saheli Marg and Big Bazar Rd, Udaipur, Rajasthan

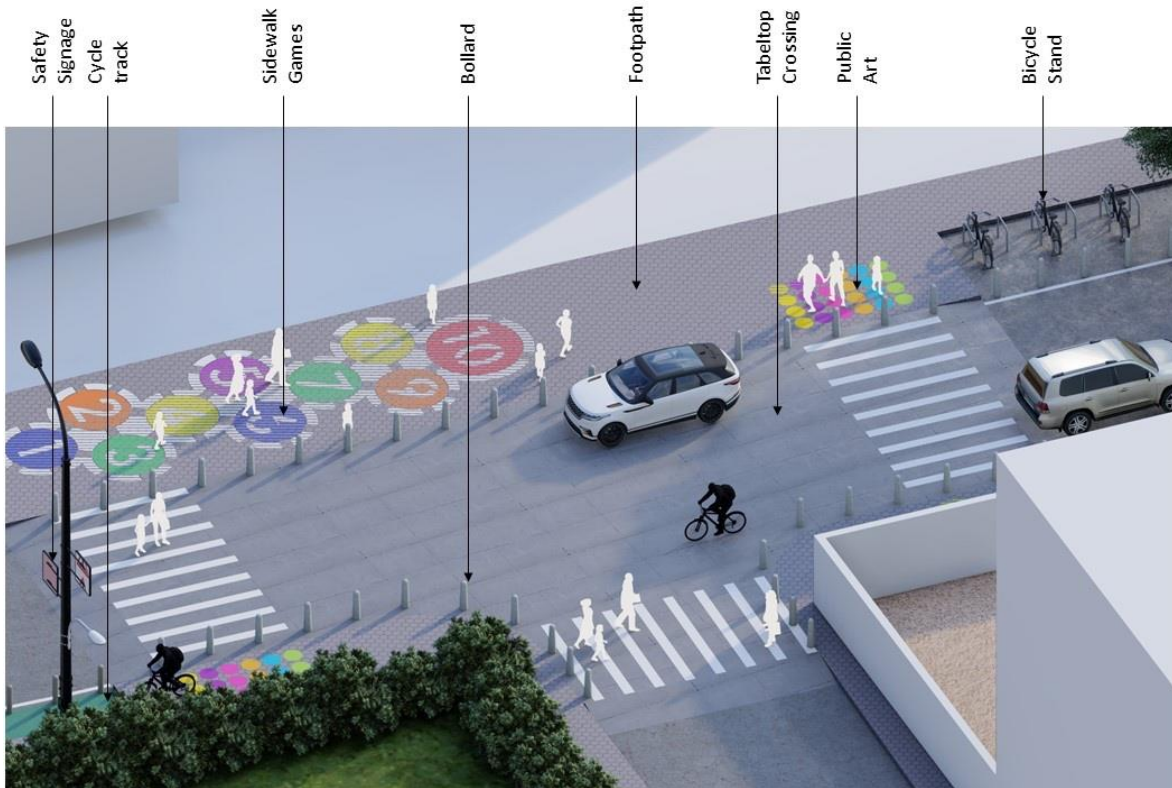

Design of Big Bazar Road

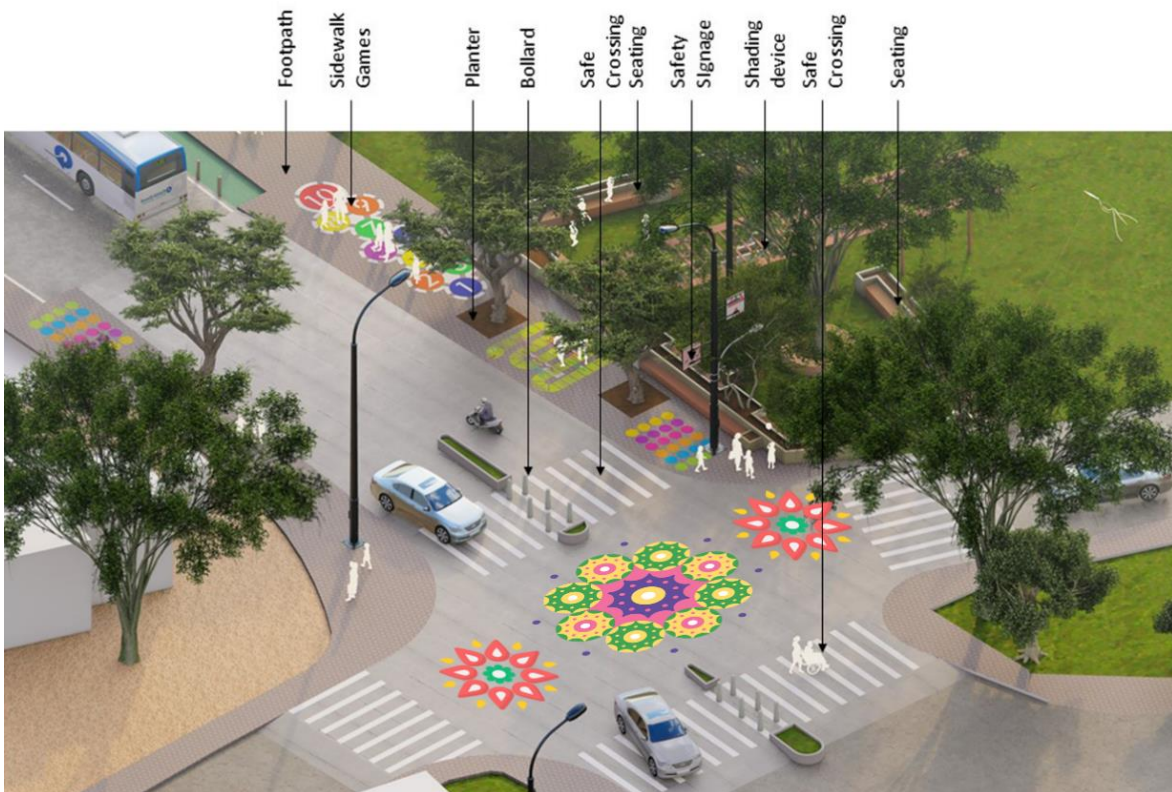

Design of Sukhadia Circle Junction

RFP for Development of three Child and Family-friendly junctions and 1.5km Connected shared Street at Saheli Marg and Big Bazar Rd, Udaipur, Rajasthan

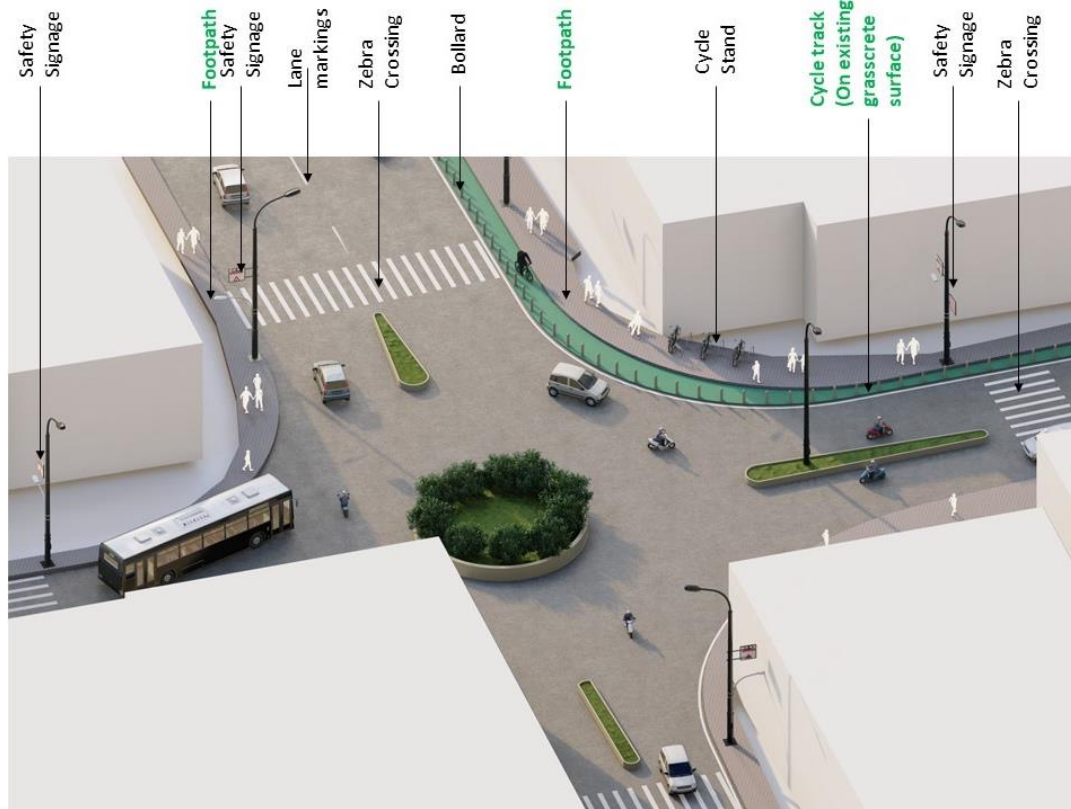

Design of UIT Circle

RFP for Development of three Child and Family-friendly junctions and 1.5km Connected shared Street at Saheli Marg and Big Bazar Rd, Udaipur, Rajasthan

SECTION 10 : ENVIRONMENT AND SOCIAL IMPACT ASSESSMENT

10.1 Environmental and Social Standards During Construction Work of the Projects:

| Environmental Issues | Management Action | Implementation Responsibilities |
|---|---|--|
| Tree Clearance | EMC will prepare a detailed transplantation and plantation plan and monitoring the implementation. | Contractor |
| Increase in Power Consumption | EMC will prepare a detailed energy conservation plan and monitoring the implementation. | Contractor |
| Loss of Local Fauna | EMC will create a plan as per EIA report (if applicable) and implement the same. | Contractor |
| Loss of Trees and Vegetation in Project Area. | EMC will prepare a detailed plantation plan and monitoring the implementation. PMC will closely watch the work of trees and vegetation removal or plantation. | Contractor/ UMC |
| Increase in Water Requirement for Domestic Purpose. | EMC to monitor and prevent the excess water consumption. | Contractor |
| Change in Land Use Pattern | Preparation of landscaping & greenery plan | Contractor |
| Loss of any Archaeological/ Cultural/ Historic Site | The operator of the facility will be planned to eliminate any odour or pollution. | Contractor |
| Air Pollution | The EMC would look into the action of the operator on regular basis. | Contractor |
| High Dust Level | (EMC through UMC can receive a feedback and the agency for corrective measures. | Contractor |
| Sediment runoff | EMC will plan the excavation e.t.c in consultation with the contractor and see to it that the mitigation measures are implemented by the contractor. | Contractor |
| Safety of Workers | EMC to monitor and ensure the security and safety of workers. | Contractor |
| Interference with the natural drainage of local system | Possible changes in natural drainage system to be avoided. UMC to closely oversee any changes in natural drainage system. | UMC/ Contractor |
| Flooding in other low-lying areas | EMC to monitor the construction and layout plan | Contractor |
| Noise Pollution | Make provision in contract to limit the noise pollution. EMC will monitor the noise. Low noise vehicles with proper maintenance and monitoring. | Contractor |

RFP for Development of three Child and Family-friendly junctions and 1.5km Connected shared Street at Saheli Marg and Big Bazar Rd, Udaipur, Rajasthan

| | | |
|---|---|-------------------|
| Disposal of excavated material | EMC to monitor the quantity and disposal. | Contractor |
| Accident during construction stage | Make provision for reporting and action | Contractor |
| Fire hazard during the construction stage | Make provision for reporting and action | Contractor |
| Lack of sewerage and sewage treatment facilities leading to unhygienic conditions | Make provision for reporting and action | Contractor |
| Air pollution due to construction vehicle usages | EMC to monitor the air pollution | Contractor |
| Water logging and cross drainage issue during construction | Make provision for reporting and action. EMC will monitor. | Contractor |
| Solid waste generation and inadequate disposal. | Make provision for reporting and action. EMC to monitor the adequacy of the solid waste disposal. | Contractor |
| Disposal of excavated material | To make the land available for disposal of excavated material. | Contractor |
| Pollution of land, ground water and surface water arising from wastes and spillage due to construction | Make provision for reporting and action. EMC to monitor the adequacy of waste disposal. | Contractor |
| Air pollution due to vehicles involved in construction work | EMC to ensure the air pollution of facility meets the norms. Regular noise monitoring & reporting. | Contractor |
| Noise pollution due to the operational activities. | EMC to monitor noise and give feedback for control | Contractor |
| Sewage and leachate treatment issues | To maintain the STP as per the standard prescribed norms. UMC to monitor the same. | Contractor |
| Periphery development | RMC initiatives to be communicated to contractor for its implementation | Contractor |

(Note – EMC stands for Environment Management Committee & RMC stands for Regional Environment Management Committee)

10.2 Environment Impact Assessment

The project proponents may have following environmental impacts-

1. As there no change in road geometry has been proposed, there would not be any change in the traffic pattern along the site.
2. As new cycle tracks and footpaths are proposed, users would be encouraged to walk and cycling in the site. As such, it is expected that users may be encouraged to shift from motorized modes of transport to non-motorised modes of transport. This may have a nominal impact on vehicular emissions along the site.
3. As street furniture, including dustbins are proposed, it is expected that it would be easier

RFP for Development of three Child and Family-friendly junctions and 1.5km Connected shared Street at Saheli Marg and Big Bazar Rd, Udaipur, Rajasthan

to maintain the site clean. This would also reduce waste dumping and associated pollution along the site.

4. The existing storm water drains are proposed to be cleaned and waste dumping in it is stopped through better enforcement. This also would lead to reduction in storm water pollution.
5. As the site is being made ITC friendly with designated crossing facilities, traffic calming etc, it is expected that the need for honking would reduce. This would reduce noise pollution in the site.
6. Most of the materials recommended for use along the stretch will have lesser carbon footprint, like use of natural and recycled materials, plantation, etc.
7. During the construction phase there might be air and noise pollution, which can be mitigated through proper construction techniques.

Proposed measures for reduction of pollution during construction works-

1. All loose items should always be covered
2. Material like sand and cement should always be covered.
3. Site should be cordoned off by installing protective sheets to avoid outside contact and pollution
4. Water should be sourced from Corporation as per local procedures and ground water should not be extracted.
5. All waste generated during construction works should be segregated, stored in covered bins and disposed regularly as per local procedures.
6. All construction debris would be covered with wet cloth and disposed frequently as per local procedures.

The on- ground construction activities for executing the proposed design shall incur few negative environmental impacts as with all other project of similar stature and moreover it being situated in the garden with high ITC and other footfall and very near to ITC Dedicated Zone, hence it is imperative to take suitable mitigation measures to avoid/ reduce/ negate/ curb/ mitigate this impacts by taking necessary steps in line with applicable local standards and norms.

Moreover, prior information shall be provided to all road and public space users (especially daily users) regarding the upcoming construction activities for them also to take precautionary measures from their side as well as avoiding this route from their daily walking, jogging route, carrying and wearing masks and/ or covering other body parts (if allergic to dust and other construction material), be away from construction site or activities etc.

A plan has been developed listing the potential impacts, appropriate mitigation measures against the same and has been explained in below mentioned table. UMC shall be in loop of any unforeseen situation, once the on- construction activities starts by joint site visits and monitoring by UMC and PMU on regular intervals.

Table 1 Environment Management Plan

| S/n | Potential Impacts | Mitigation Measures |
|-----|---|---|
| 1 | Large quantity of waste soil, stones and debris due to Excavation, it being greenfield site | <ul style="list-style-type: none">• Utilizing surplus soil, stones for beneficial purposes such as on- site construction activities and filling up low lying areas• Disposal of extra items (if any) as per applicable UMC norms and standards |
| 2 | Earthwork excavation, refilling, handling and transportation of construction materials (like sand | <ul style="list-style-type: none">• Cover (by tarpaulins) or damp/ sprinkling down excavated, construction material (aggregates, loose soil etc.) while loading, unloading, levelling and on |

RFP for Development of three Child and Family-friendly junctions and 1.5km Connected shared Street at Saheli Marg and Big Bazar Rd, Udaipur, Rajasthan

| S/n | Potential Impacts | Mitigation Measures |
|-----|---|---|
| | and aggregate), producing large volumes of dust | requirement basis <ul style="list-style-type: none"> • Cover (by tarpaulins) the same while transportation of same • Transportation of material mostly during non- operational hours |
| 3 | Cutting and pruning of existing trees (one dead tree at site), dense unplanned vegetation, weeds etc. | <ul style="list-style-type: none"> • Using the cut tree(s) trunk in on- site construction activities, as an design element such as wooden logs- seating cum playing equipment • Using of weeds and other natural material as manure by proper disposal of the same |
| 4 | Possibility of water collecting in void created by excavation and/ or construction activities | Creation of temporary drain on- site connecting the same to the nearest drain for maintain cleanliness during construction activities |
| 5 | On- site construction activities, especially excavation might cause noise and vibrations | <ul style="list-style-type: none"> • Utilize modern vehicles and machinery to limit noise and exhaust emissions • Such activities to be scheduled during non- operational hours |
| 6 | Damage to existing on- site (underground) infrastructure | <ul style="list-style-type: none"> • As such nothing has been found on site, however imperative to confirm location of underground infrastructure/utilities (in any) before start of work • Alternate arrangement of the same |
| 7 | Construction workers and garden users at risk from any on- site accident(s) | <ul style="list-style-type: none"> • Following standard and safe construction practices • Excluding garden users from the site by enclosing, barricading the construction area • Providing workers with appropriate Personal Protective Equipment (helmet, hand gloves, boots, masks, safety hoists when working at height, etc.) as per set standards • Follow standard practices of safety checks as prescribed before use of equipments such as cranes, hoists, etc. |

10.3 Social Impact Assessment:

The project site has high footfall of local, national, and international tourists. The site also has high concentration of hawkers at Saheliyon Ki Bari Junction and Sukhadia Circle junction. At the time of construction, the users of the site may temporarily be affected. Following mitigation measures should be taken during construction:

- During construction, alternate movement paths which are comfortable, safe and accessible should be planned by the contractor in consultation with UMC and other concerned agencies.
- Before the start of the construction, all vendors should be informed about the project and told that they may be temporarily shifted within the site. They should also be informed that the project does not entail any form of eviction.
- During construction, the contractor should ensure that no vending stalls are broken by the construction activities. In the event vending stalls are to be moved, assistance from UMC and concerned police station should be taken.
- Before construction all residents and shop owners adjoining the project site should be informed about the project and told to remove illegal encroachments. The contractor should take UMC and Local police stations assistance in the matter.

RFP for Development of three Child and Family-friendly junctions and 1.5km Connected shared Street at Saheli Marg and Big Bazar Rd, Udaipur, Rajasthan

10.4 Safety Requirements:

The contractor is responsible for maintaining an incident/hazard free work environment. In compliance with these provisions, the contractor shall comply with the latest edition of the contractor safety requirement and perform the following:

1. Contractor is expected to pre-plan all work to minimize the potential for personal injury and property damage.
 2. Develop the plan in project specific nature which is designed to anticipate and identify hazards before work begins. Know in advance what measures will be taken to eliminate hazards or adequately control the anticipated risks for each scope of work. This information shall include, but is not limited to scope of work, sequence of activities, site specific fall protection, high angle rescue procedures, safety control methods, and excavations. The planning doesn't stop at pre-planning stage but it's a continuous process of assessment and evaluation. When changes occur and new hazards are identified during the project, the work should be suspended while the plan is revised.
 3. Ensure all subcontractors, suppliers and vendors are informed of their obligations with regard to safety and contractor safety requirements.
 4. Contractor or their contractors/sub-contractors with 25 or more employees in a single shift will establish a full-time position of a Contractor Safety Manager to perform safety inspections and training services.
 5. Contractor shall maintain its own safety program for its employees that shall include as a minimum a review of 1) hazards present in the area in they will be working 2) the personal protective equipment (PPE) and apparel the workers will be required to use or wear as specified under Occupational Safety and Health Administration (OSHA).
 6. Contractor shall provide and maintain a chemical and flammable material storage area as described in the contractor safety requirement. Contractor shall be responsible for the control, availability and use of necessary safety equipment including Personal Protective Equipment (PPE) and apparels for the contractor employees.
 7. Take an active part in all supervisory safety meetings including the discussion of observed unsafe work practices or conditions and a review of any incidents and corrective actions.
 8. Report all injuries and incidents in a timely manner in accordance with federal and/or state laws and regulations and the contractor safety requirements.
 9. Analyse all incidents and implement immediate corrective actions.
 10. Maintain list on-site of personnel available for first aid and emergency treatment for injured Contractor employees.
 11. In the event of a work-related incident resulting in a Contractor employee injury or near miss, Contractor shall notify their appointed representative immediately.
 12. Contractors shall provide the appointed representative with an initial report of incident, in writing, within 24 hours of the accident. Hard copy or electronic formats are acceptable.
 13. Contractors shall provide a completed accident investigation report within three (3)
-

RFP for Development of three Child and Family-friendly junctions and 1.5km Connected shared Street at Saheli Marg and Big Bazar Rd, Udaipur, Rajasthan

working days of the incident. In the event, their investigation requires more time to investigate due to complexity of the incident, Contractors shall communicate to the appointed Representative in writing including intimation to higher authorities of availability and use of necessary safety equipment including personal equipment (PPE) and apparels for the contractor employees.

14. All first aid injuries shall be documented for record keeping purposes in the event if a first aid case develops into a contractor employee injury, accident reporting and investigation procedure be initiated as outlined previously.
15. Contractor shall comply with the latest revision safety rules and procedures permit. Contractor shall provide adequate fire protection equipment in each of their storage areas, offices and other temporary structures.
16. Contractor is responsible for orienting employees on the specific safety rules that must be followed by all persons working on project facilities. Other PPE (Personal Protective Equipment) is also required in accordance with the appropriate safety standards and equipment as set by the manufacturer's specifications. A list of the minimum personal protective requirements is as follows.
 - a) The contractor shall be responsible for providing and ensuring the use of required PPE (Personal Protective Equipment) for its employees.
 - b) Approved safety helmet shall always be worn while on the site. It is required that each employee use ANSI (American National Standard Institute) approved safety helmets.
 - c) Safety glasses, which meet applicable ANSI standard are always required while on the site and should include approved side shields. On clear safety glasses are allowed to be used inside buildings and enclosed structures. Shaded goggles and hoods may be used while welding or cutting requires. Prescription safety glasses with self-tinting capabilities may be worn on site.
 - e) Contractors, vendors and visitors will be required to meet these same standards.
 - f) Good housekeeping affects safety, quality and production. It is the responsibility of contractor on site to keep their work area clean. Contractor is responsible for trash and debris by their work site.

10.5 Operation and maintenance

Regular maintenance of items under Part A – Saheli Marg, Park B – Big Bazaar Road; & other supporting devices installed shall be ensured for uninterrupted accessibility. All the broken/damaged elements shall be replaced as per the specifications of the contract. These should be regularly checked before, during and after rains as well. Proper & regular cleaning of dust on the playing equipment's shall be done to achieve proper usability. In addition to this the following points shall be taken care of:

- Operation and maintenance of the three Child and Family-friendly junctions and 1.5km Connected shared Street at Saheli Marg and Big Bazar Rd, Udaipur, Rajasthan and all the new facilities provided should be taken care of while implementing and operating them.
-

RFP for Development of three Child and Family-friendly junctions and 1.5km Connected shared Street at Saheli Marg and Big Bazar Rd, Udaipur, Rajasthan

- The concerned agency, i.e. UMC & UIT would have to keep the sites clean.
 - All street furniture, like bollards, benches, dustbins etc. would have to be repaired / replaced from time to time based on its wear and tear. All in accordance with the contract.
 - Playing & other equipments- slides, all side fencing, lights poles & its ancillary infrastructure (Electrical board/ unit, wires/ cables, switches etc.), pre cast RCC benches. and any element installed/ build as a part of this contract
 - All electrical fixtures would have to be checked at least once a month and preferably every fortnight and shall be maintained in accordance with the contract.
 - All plants would have to be supplied with manure, water and regular maintenance by the horticulture department. Plants which dry out, will have to be replaced with new plants/ saplings.
 - Regular watering of Green Areas/ Elements- Lawns, Mounds, Shrubs, Hedging, Tress, Saplings & other plantations.
 - Regular cutting and pruning of plantation- grass, shrubs, saplings, tress etc.; using mechanical and manual means as deemed fit for their healthy growth;
 - Collection & disposal of all the waste material as per the direction of Engineer in charge.
 - Replacing dead planters. shrubs, saplings, trees with the same size, shape and/ or age etc. in absence of regular upkeep and/ or for any other reasons.
 - The Contractor shall comply with the instructions given by the Engineer or a delegated assistant. If the Engineer or a delegated assistant (a) gives an oral instruction, (b) receives a written confirmation of the instruction, from (or on behalf of) the Contractor, within two working days after giving the instruction, and (c) does not reply by issuing a written rejection and/or instruction within two working days after receiving the confirmation, then the written confirmation shall constitute the written instruction of the Engineer or delegated assistant (as the case may be).
 - All lane markings, signage, rumble strips etc, would have to be repaired/ re-drawing from time to time based on its wear and tear.
 - All wall art and street art would have to be repainted from time to time, based on its wear and tear.
-

RFP for Development of three Child and Family-friendly junctions and 1.5km Connected shared Street at Saheli Marg and Big Bazar Rd, Udaipur, Rajasthan

SECTION 11: DRAWINGS & BILL OF QUANTITIES

11.1 DRAWINGS

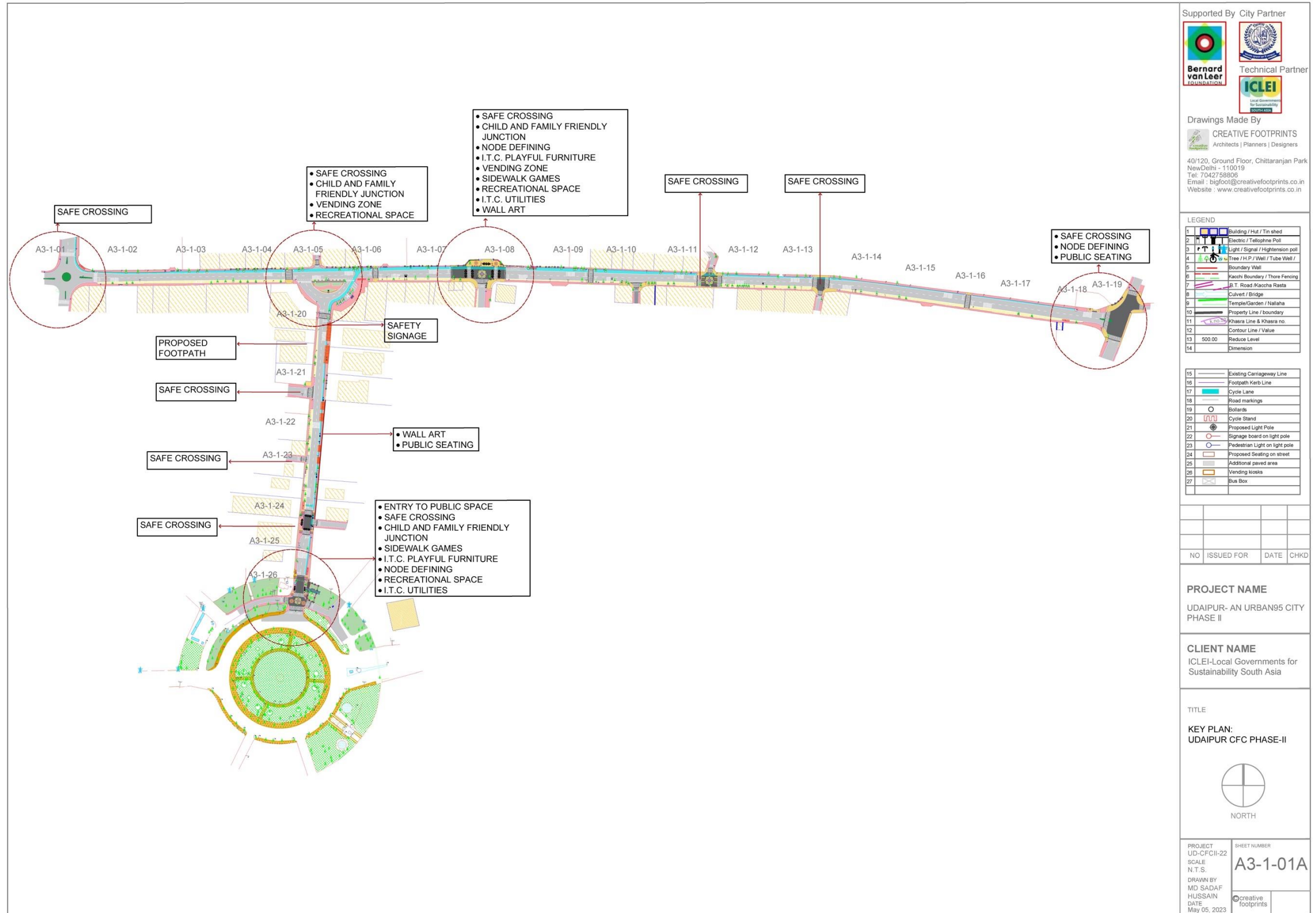

Supported By City Partner

Technical Partner

Drawings Made By

CREATIVE FOOTPRINTS
Architects | Planners | Designers

40/120, Ground Floor, Chittaranjan Park
New Delhi - 110019
Tel: 7042758805
Email: bigfoot@creativefootprints.co.in
Website: www.creativefootprints.co.in

LEGEND

| | |
|----|------------------------------------|
| 1 | Building / Hut / Tin shed |
| 2 | Electric / Telglobe Pole |
| 3 | Light / Signal / Heightension post |
| 4 | Tree / H.P./ Well / Tube Well / |
| 5 | Boundary Wall |
| 6 | Kaachi Boundary / Thorn Fencing |
| 7 | B.T. Road /Kaacha Rasta |
| 8 | Culvert / Bridge |
| 9 | Temple/Garden / Nalaha |
| 10 | Property Line / boundary |
| 11 | Khassra Line & Khassra no. |
| 12 | Contour Line / Value |
| 13 | 500.00 Reduce Level |
| 14 | Dimension |
| 15 | Existing Carriageway Line |
| 16 | Footpath Kerb Line |
| 17 | Cycle Lane |
| 18 | Road markings |
| 19 | Bollards |
| 20 | Cycle Stand |
| 21 | Proposed Light Pole |
| 22 | Signage board on light pole |
| 23 | Pedestrian Light on light pole |
| 24 | Proposed Seating on street |
| 25 | Additional paved area |
| 26 | Vending kiosks |
| 27 | Bus Box |

| NO | ISSUED FOR | DATE | CHKD |
|----|------------|------|------|
| | | | |

PROJECT NAME
UDAIPUR- AN URBAN95 CITY PHASE II

CLIENT NAME
ICLEI-Local Governments for Sustainability South Asia

TITLE
KEY PLAN:
UDAIPUR CFC PHASE-II

NORTH

| | |
|------------------------|--------------------------|
| PROJECT UD-CFCII-22 | SHEET NUMBER A3-1-01A |
| SCALE N.T.S. | |
| DRAWN BY MD SADAF | |
| HUSSAIN | |
| DATE May 05, 2023 | |

RFP for Development of three Child and Family-friendly junctions and 1.5km Connected shared Street at Saheli Marg and Big Bazar Rd, Udaipur, Rajasthan

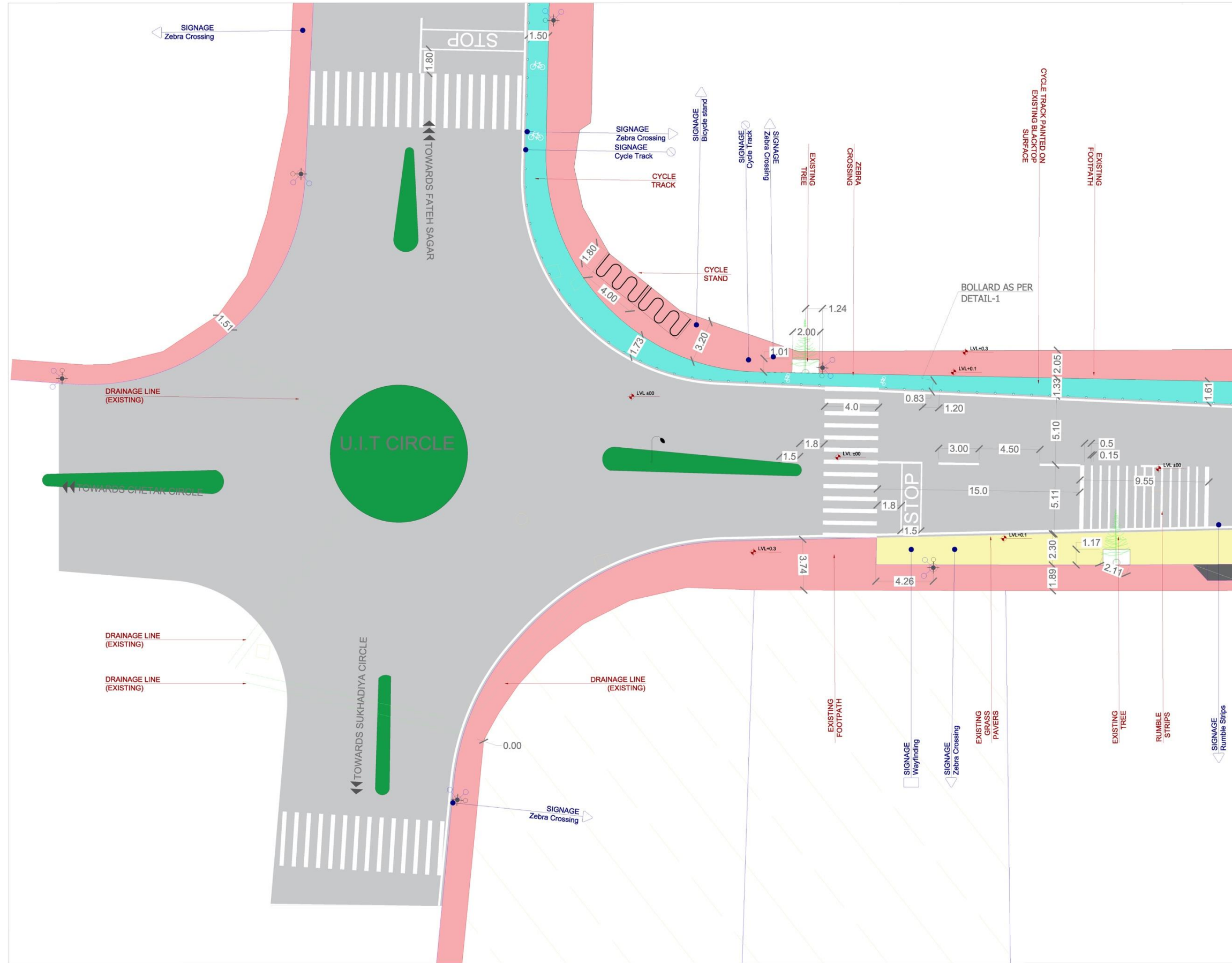

Supported By City Partner

Technical Partner

Drawings Made By

CREATIVE FOOTPRINTS
Architects | Planners | Designers

40/120, Ground Floor, Chittaranjan Park
New Delhi - 110019
Tel: 7042758806
Email: bigfoot@creativefootprints.co.in
Website: www.creativefootprints.co.in

LEGEND: EXISTING FEATURES

| | |
|----|------------------------------------|
| 1 | Building / Hut / Tin shed |
| 2 | Electric / Telephone Pole |
| 3 | Light / Signal / High tension pole |
| 4 | Tree / H.P. / Well / Tube Well / |
| 5 | Boundary Wall |
| 6 | Kacchi Boundary / Thore Fencing |
| 7 | B.T. Road / Kaccha Rasta |
| 8 | Culvert / Bridge |
| 9 | Temple/Garden / Nallaha |
| 10 | Property Line / boundary |
| 11 | K.no.55/ Khassa Line & Khassa no. |
| 12 | Contour Line / Value |
| 13 | 500.00 Reduce Level |
| 14 | Dimension |

LEGEND: PROPOSED FEATURES

| | |
|----|--------------------------------|
| 15 | Existing Carriageway Line |
| 16 | EXISTING FOOTPATH |
| 17 | Proposed Footpath |
| 18 | Road markings |
| 19 | Bollards |
| 20 | Cycle Stand |
| 21 | Proposed Light Pole |
| 22 | Signage board on light pole |
| 23 | Pedestrian Light on light pole |
| 24 | Proposed Seating on street |
| 25 | Additional paved area |
| 26 | Vending kiosks |
| 27 | Bus Box |

| NO | ISSUED FOR | DATE | CHKD |
|----|------------|------|------|
| | | | |

PROJECT NAME
UDAIPUR- AN URBAN95 CITY PHASE II

CLIENT NAME
ICLEI-Local Governments for Sustainability South Asia

TITLE
UDAIPUR CFC PHASE-II



PROJECT UD-CFCII-22
SCALE 1:250
DRAWN BY MD SADAF HUSSAIN
DATE May 05, 2023

SHEET NUMBER
A3-1-01

© creative footprints

RFP for Development of three Child and Family-friendly junctions and 1.5km Connected shared Street at Saheli Marg and Big Bazar Rd, Udaipur, Rajasthan

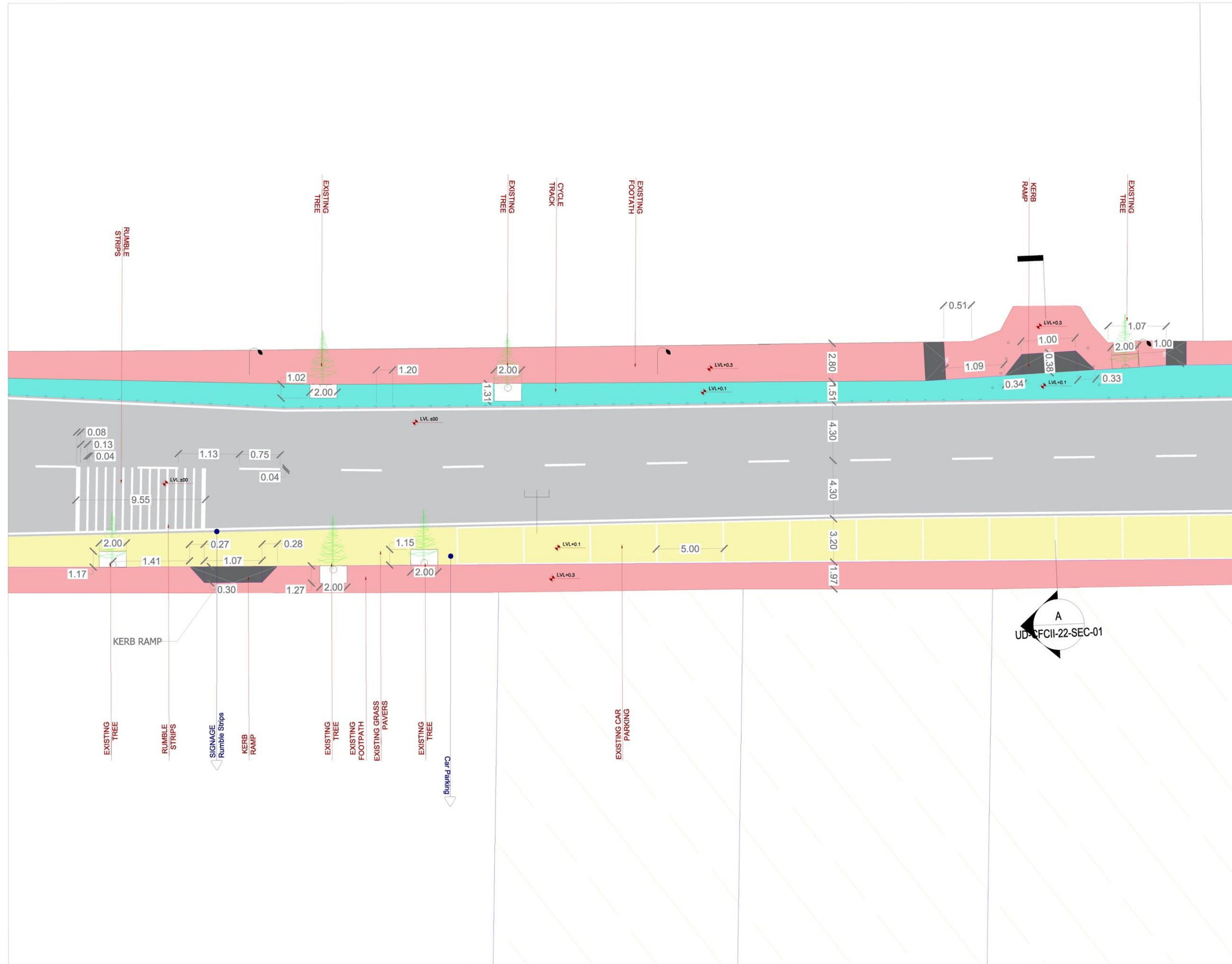

Supported By City Partner

Technical Partner

Drawings Made By

CREATIVE FOOTPRINTS
Architects | Planners | Designers

40/120, Ground Floor, Chittaranjan Park
New Delhi - 110019
Tel: 7042758906
Email : bigfoot@creativefootprints.co.in
Website : www.creativefootprints.co.in

LEGEND: EXISTING FEATURES

| | |
|----|-----------------------------------|
| 1 | Building / Hut / Tin shed |
| 2 | Electric / Telephone Pole |
| 3 | Light / Signal / Hightension pole |
| 4 | Tree / H.P / Well / Tube Well / |
| 5 | Boundary Wall |
| 6 | Kacchi Boundary / Thore Fencing |
| 7 | B.T. Road /Kaccha Rasta |
| 8 | Culvert / Bridge |
| 9 | Temple/Garden / Nallaha |
| 10 | Property Line / boundary |
| 11 | Khasra no. / Khasra no. |
| 12 | Contour Line / Value |
| 13 | 500.00 Reduce Level |
| 14 | Dimension |

LEGEND: PROPOSED FEATURES

| | |
|----|--------------------------------|
| 15 | Existing Carriageway Line |
| 16 | EXISTING FOOTPATH |
| 17 | Proposed Footpath |
| 18 | Road markings |
| 19 | Bollards |
| 20 | Cycle Stand |
| 21 | Proposed Light Pole |
| 22 | Signage board on light pole |
| 23 | Pedestrian Light on light pole |
| 24 | Proposed Seating on street |
| 25 | Additional paved area |
| 26 | Vending kiosks |
| 27 | Bus Box |

| NO | ISSUED FOR | DATE | CHKD |
|----|------------|------|------|
| | | | |

PROJECT NAME
UDAIPUR- AN URBAN95 CITY PHASE II

CLIENT NAME
ICLEI-Local Governments for Sustainability South Asia

TITLE
UDAIPUR CFC PHASE-II

NORTH

PROJECT UD-CFCII-22
SCALE 1:250
DRAWN BY MD SADAF HUSSAIN
DATE May 05, 2023

SHEET NUMBER
A3-1-02
C creative footprints

RFP for Development of three Child and Family-friendly junctions and 1.5km Connected shared Street at Saheli Marg and Big Bazar Rd, Udaipur, Rajasthan

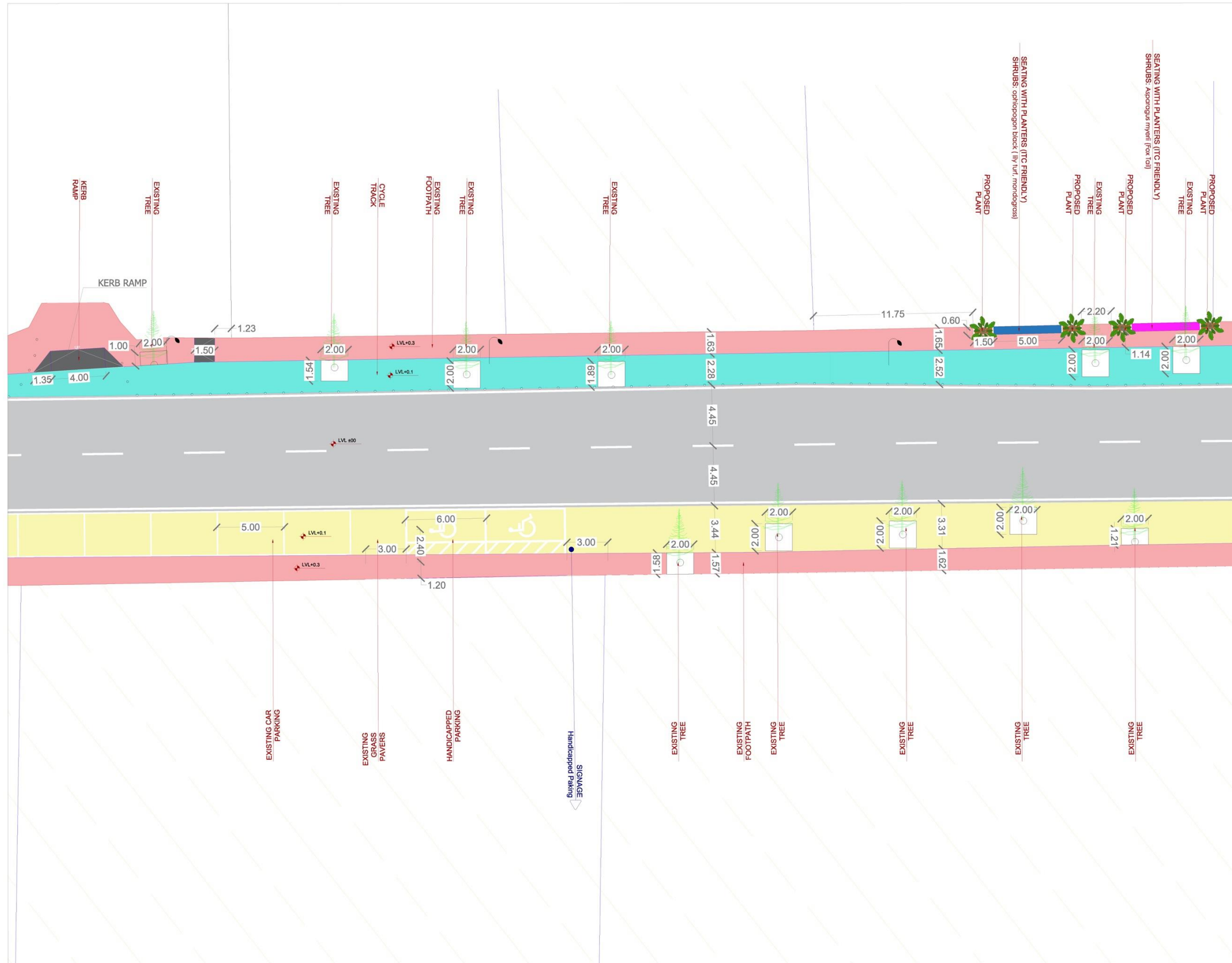

Supported By City Partner

 Technical Partner
 Drawings Made By
 CREATIVE FOOTPRINTS
 Architects | Planners | Designers
 40/120, Ground Floor, Chittaranjan Park
 New Delhi - 110019
 Tel: 7042758806
 Email: bigfoot@creativefootprints.co.in
 Website: www.creativefootprints.co.in

LEGEND: EXISTING FEATURES

| | |
|----|------------------------------------|
| 1 | Building / Hut / Tin shed |
| 2 | Electric / Telephone Pole |
| 3 | Light / Signal / High tension pole |
| 4 | Tree / H.P. Well / Tube Well / |
| 5 | Boundary Wall |
| 6 | Kaschi Boundary / Thore Fencing |
| 7 | B.T. Road / Kascha Rasta |
| 8 | Culvert / Bridge |
| 9 | Temple/Garden / Nallah |
| 10 | Property Line / boundary |
| 11 | K.No. 527 Kharsa Line & Kharsa no. |
| 12 | Contour Line / Value |
| 13 | 500.00 Reduce Level |
| 14 | Dimension |

LEGEND: PROPOSED FEATURES

| | |
|----|--------------------------------|
| 15 | Existing Carriageway Line |
| 16 | EXISTING FOOTPATH |
| 17 | Kerb Line |
| 18 | Cycle Lane |
| 19 | Road markings |
| 20 | Bollards |
| 21 | Cycle Stand |
| 22 | Proposed Light Pole |
| 23 | Signage board on light pole |
| 24 | Pedestrian Light on light pole |
| 25 | Proposed Seating on street |
| 26 | Additional paved area |
| 27 | Vending kiosks |
| 28 | Bus Box |

| NO | ISSUED FOR | DATE | CHKD |
|----|------------|------|------|
| | | | |

PROJECT NAME
 UDAIPUR- AN URBAN95 CITY PHASE II

CLIENT NAME
 ICLEI-Local Governments for Sustainability South Asia

TITLE
 UDAIPUR CFC PHASE-II



PROJECT UD-CFCII-22
 SCALE 1:250
 DRAWN BY MD SADAF HUSSAIN
 DATE May 05, 2023

SHEET NUMBER
A3-1-03
 C creative footprints

RFP for Development of three Child and Family-friendly junctions and 1.5km Connected shared Street at Saheli Marg and Big Bazar Rd, Udaipur, Rajasthan

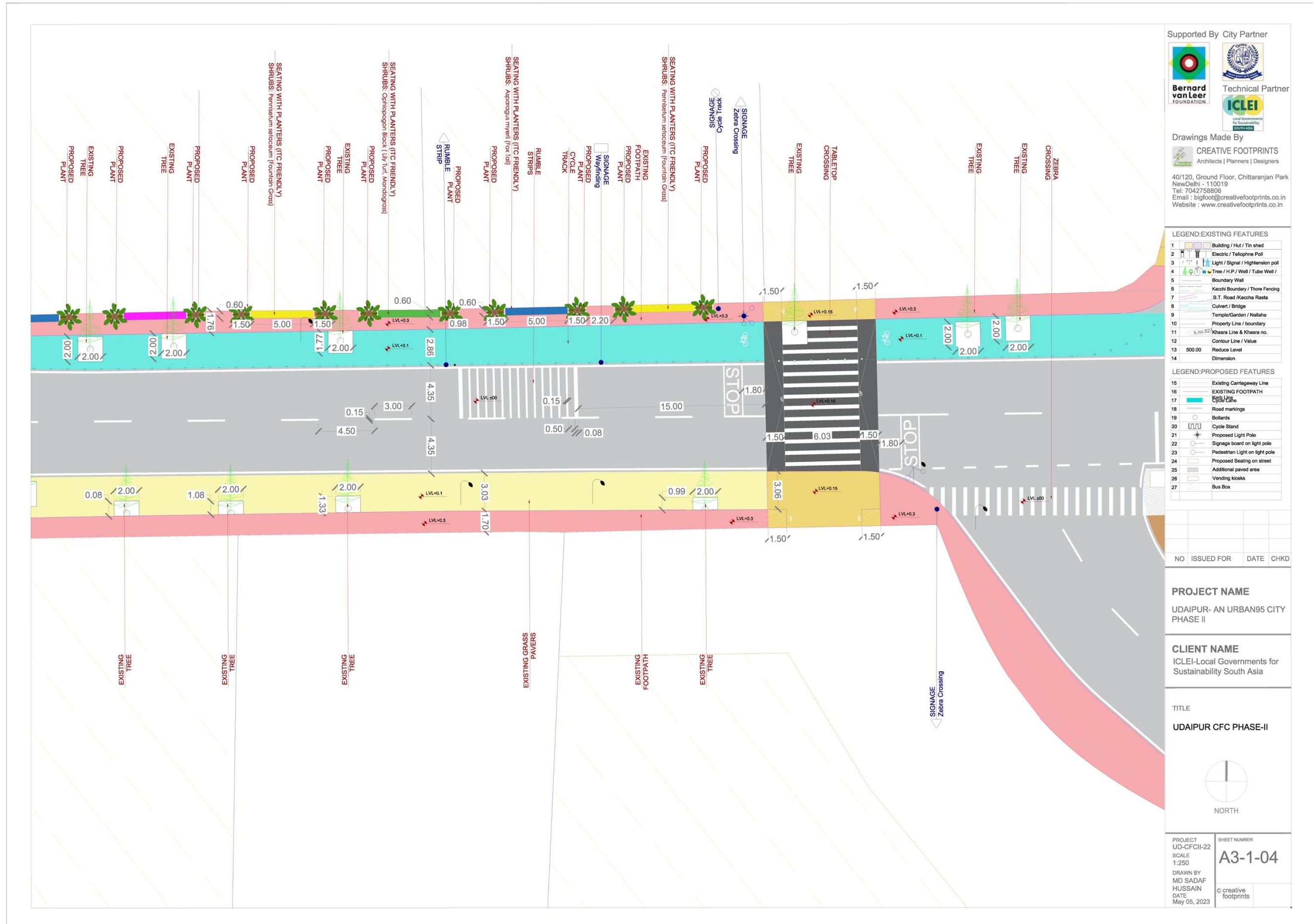

Supported By City Partner

Bernard van Leer FOUNDATION

Technical Partner

ICLEI
Local Governments for Sustainability

Drawings Made By

CREATIVE FOOTPRINTS
Architects | Planners | Designers

40/120, Ground Floor, Chittaranjan Park
New Delhi - 110019
Tel: 7042758806
Email: bigfoot@creativefootprints.co.in
Website: www.creativefootprints.co.in

LEGEND: EXISTING FEATURES

| | |
|----|------------------------------------|
| 1 | Building / Hut / Tin shed |
| 2 | Electric / Telephone Pole |
| 3 | Light / Signal / High tension pole |
| 4 | Tree / H.P.J Well / Tube Well / |
| 5 | Boundary Wall |
| 6 | Kaschi Boundary / Thore Fencing |
| 7 | B.T. Road / Kascha Rasta |
| 8 | Culvert / Bridge |
| 9 | Temple/Garden / Nallaha |
| 10 | Property Line / boundary |
| 11 | Khasra Line & Khasra no. |
| 12 | Contour Line / Value |
| 13 | 500.00 Reduce Level |
| 14 | Dimension |

LEGEND: PROPOSED FEATURES

| | |
|----|--------------------------------|
| 15 | Existing Carriageway Line |
| 16 | EXISTING FOOTPATH |
| 17 | Kaschi Line |
| 18 | Cycle Lane |
| 19 | Road markings |
| 20 | Bollards |
| 21 | Cycle Stand |
| 22 | Proposed Light Pole |
| 23 | Signage board on light pole |
| 24 | Pedestrian Light on light pole |
| 25 | Proposed Seating on street |
| 26 | Additional paved area |
| 27 | Vending kiosks |
| 28 | Bus Box |

| NO | ISSUED FOR | DATE | CHKD |
|----|------------|------|------|
| | | | |

PROJECT NAME
UDAIPUR- AN URBAN95 CITY PHASE II

CLIENT NAME
ICLEI-Local Governments for Sustainability South Asia

TITLE
UDAIPUR CFC PHASE-II

NORTH

PROJECT UD-CFCII-22
SCALE 1:250
DRAWN BY MD SADAF HUSSAIN
DATE May 05, 2023

SHEET NUMBER **A3-1-04**
C creative footprints

RFP for Development of three Child and Family-friendly junctions and 1.5km Connected shared Street at Saheli Marg and Big Bazar Rd, Udaipur, Rajasthan

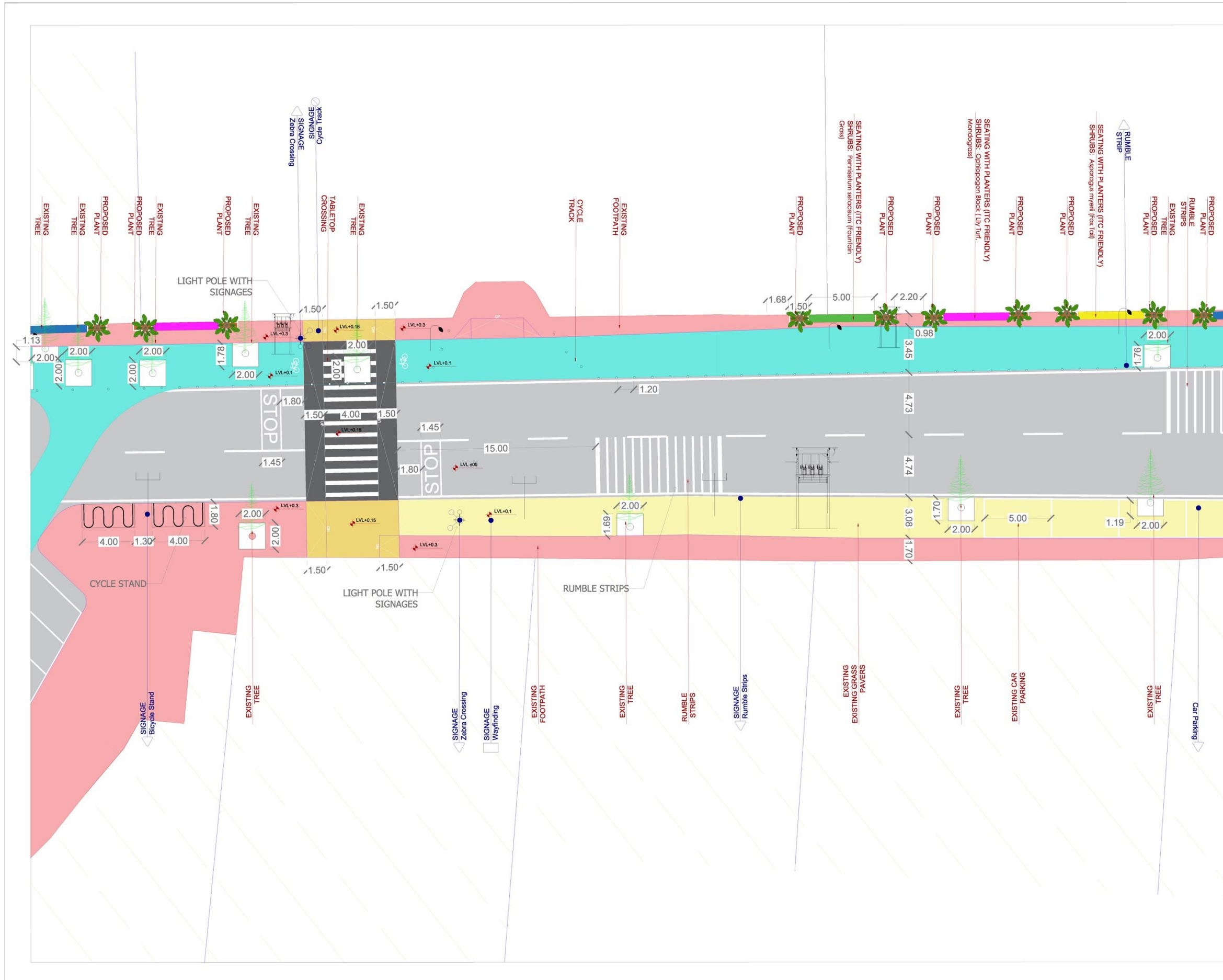

Supported By City Partner

Technical Partner

Drawings Made By

CREATIVE FOOTPRINTS
Architects | Planners | Designers

40/120, Ground Floor, Chittaranjan Park
New Delhi - 110019
Tel: 7042758806
Email: bigfoot@creativefootprints.co.in
Website: www.creativefootprints.co.in

LEGEND: EXISTING FEATURES

- Building / Hut / Tin shed
- Electric / Telephone Pole
- Light / Signal / High tension pole
- Tree / H.P. Well / Tube Well /
- Boundary Wall
- Kaschi Boundary / Thore Fencing
- B.T. Road / Kascha Rasta
- Culvert / Bridge
- Temple/Garden / Nallaha
- Property Line / boundary
- Khasra Line & Khasra no.
- Contour Line / Value
- 500.00 Reduce Level
- Dimension

LEGEND: PROPOSED FEATURES

- Existing Carriageway Line
- EXISTING FOOTPATH
- Left Lane
- Right Lane
- Road markings
- Bollards
- Cycle Stand
- Proposed Light Pole
- Signage board on light pole
- Pedestrian Light on light pole
- Proposed Seating on street
- Additional paved area
- Vending kiosks
- Bus Box

| NO | ISSUED FOR | DATE | CHKD |
|----|------------|------|------|
| | | | |

PROJECT NAME
UDAIPUR- AN URBAN95 CITY PHASE II

CLIENT NAME
ICLEI-Local Governments for Sustainability South Asia

TITLE
UDAIPUR CFC PHASE-II



PROJECT UD-CFCII-22
SCALE 1:250
DRAWN BY MD SADAF HUSSAIN
DATE May 05, 2023

SHEET NUMBER
A3-1-06
C creative footprints

RFP for Development of three Child and Family-friendly junctions and 1.5km Connected shared Street at Saheli Marg and Big Bazar Rd, Udaipur, Rajasthan

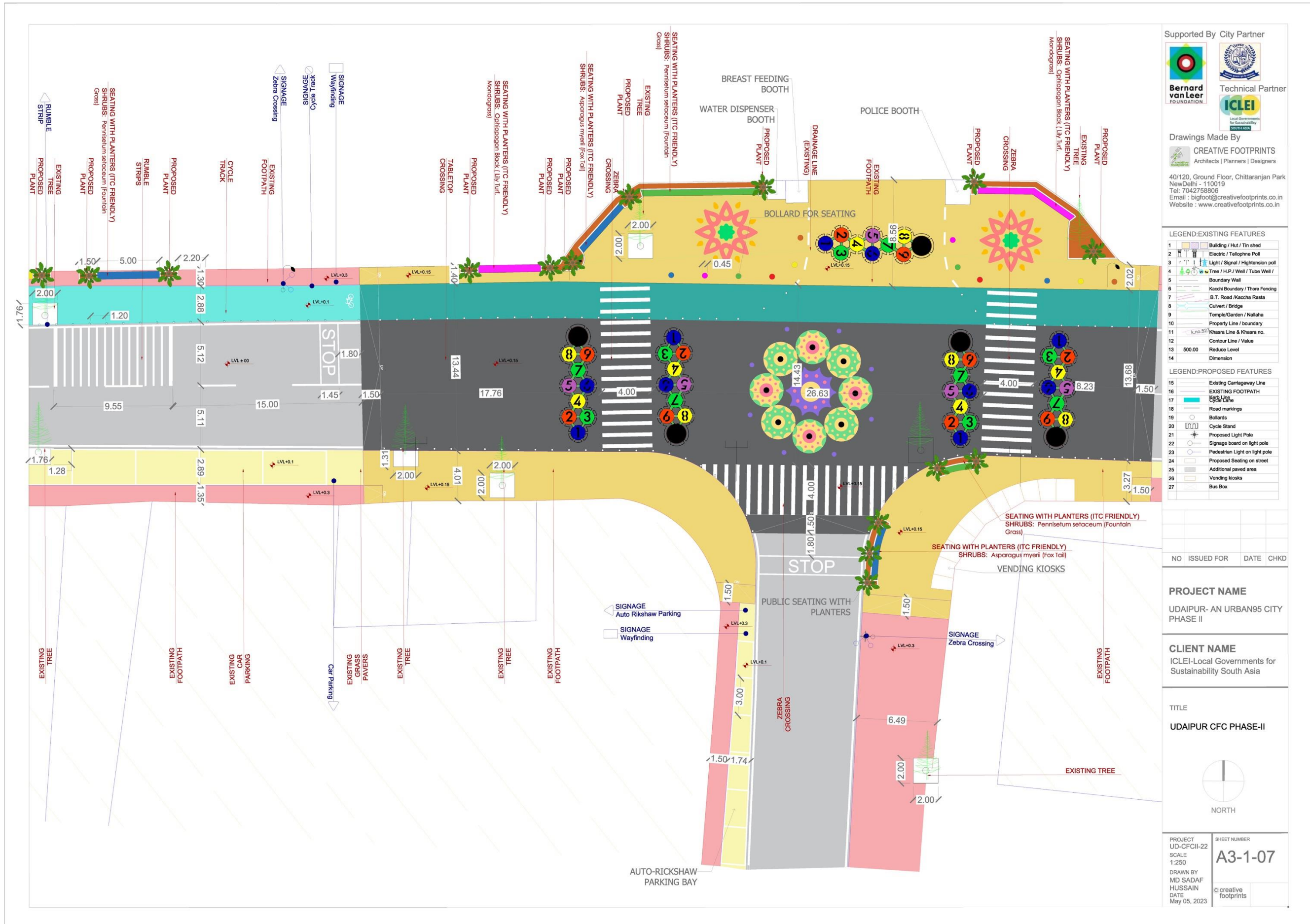

Supported By City Partner

Bernard van Leer FOUNDATION

Technical Partner

ICLEI Local Governments for Sustainability

Drawings Made By

CREATIVE FOOTPRINTS Architects | Planners | Designers

40/120, Ground Floor, Chittaranjan Park NewDelhi - 110019
Tel: 7042758806
Email: bigfoot@creativefootprints.co.in
Website: www.creativefootprints.co.in

LEGEND: EXISTING FEATURES

| | |
|----|------------------------------------|
| 1 | Building / Hut / Tin shed |
| 2 | Electric / Telegraph Pole |
| 3 | Light / Signal / High tension pole |
| 4 | Tree / H.P. Well / Tube Well / |
| 5 | Boundary Wall |
| 6 | Kascha Boundary / Thore Fencing |
| 7 | B.T. Road / Kascha Rasta |
| 8 | Culvert / Bridge |
| 9 | Temple/Garden / Nallaha |
| 10 | Property Line / boundary |
| 11 | Khasra Line & Khasra no. |
| 12 | Contour Line / Value |
| 13 | 500.00 Reduce Level |
| 14 | Dimension |

LEGEND: PROPOSED FEATURES

| | |
|----|--------------------------------|
| 15 | Existing Carriageway Line |
| 16 | EXISTING FOOTPATH |
| 17 | Light Pole |
| 18 | Road markings |
| 19 | Bollards |
| 20 | Cycle Stand |
| 21 | Proposed Light Pole |
| 22 | Signage board on light pole |
| 23 | Pedestrian Light on light pole |
| 24 | Proposed Seating on street |
| 25 | Additional paved area |
| 26 | Vending kiosks |
| 27 | Bus Box |

| NO | ISSUED FOR | DATE | CHKD |
|----|------------|------|------|
| | | | |

PROJECT NAME
UDAIPUR- AN URBAN95 CITY PHASE II

CLIENT NAME
ICLEI-Local Governments for Sustainability South Asia

TITLE
UDAIPUR CFC PHASE-II

NORTH

PROJECT UD-CFCII-22
SCALE 1:250
DRAWN BY MD SADAF HUSSAIN
DATE May 05, 2023

SHEET NUMBER
A3-1-07
C creative footprints

RFP for Development of three Child and Family-friendly junctions and 1.5km Connected shared Street at Saheli Marg and Big Bazar Rd, Udaipur, Rajasthan

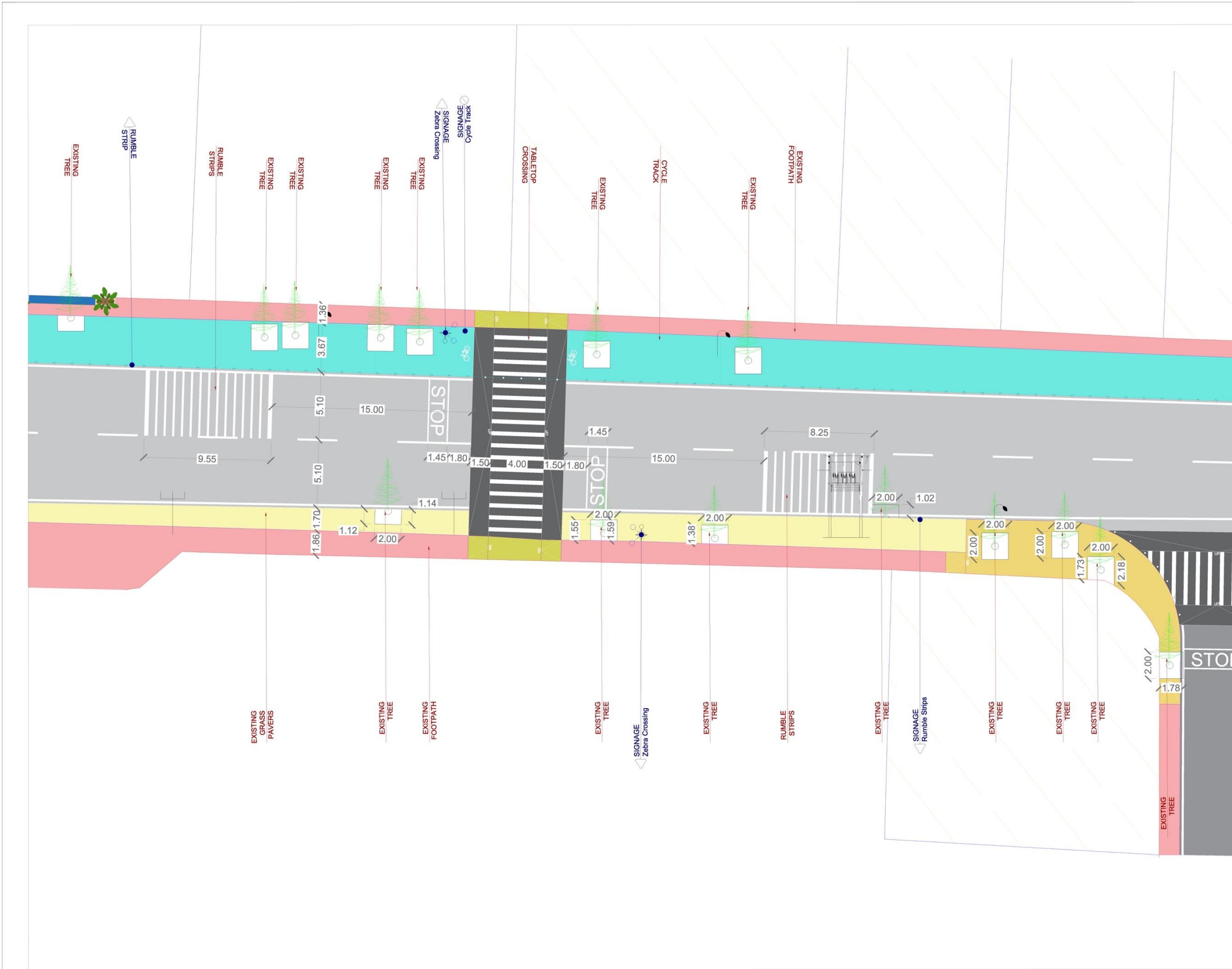

Supported By City Partner

Bernard van Leer FOUNDATION

ICLEI Local Governments for Sustainability

Technical Partner

Drawings Made By

CREATIVE FOOTPRINTS
Architects | Planners | Designers

40/120, Ground Floor, Chittaranjan Park
New Delhi - 110019
Tel: 7042758806
Email: bigfoot@creativefootprints.co.in
Website: www.creativefootprints.co.in

LEGEND-EXISTING FEATURES

| | |
|----|------------------------------------|
| 1 | Building / Hut / Tin shed |
| 2 | Electric / Telephone Pole |
| 3 | Light / Signal / High tension pole |
| 4 | Tree / H.P./ Well / Tube Well / |
| 5 | Boundary Wall |
| 6 | Kacchi Boundary / Thore Fencing |
| 7 | B.T. Road / Kaccha Rasta |
| 8 | Culvert / Bridge |
| 9 | Temple/Garden / Nallaha |
| 10 | Property Line / boundary |
| 11 | k.no.552/ Khassa Line & Khassa no. |
| 12 | Contour Line / Value |
| 13 | 500.00 Reduce Level |
| 14 | Dimension |

LEGEND-PROPOSED FEATURES

| | |
|----|--------------------------------|
| 15 | Existing Carriageway Line |
| 16 | EXISTING FOOTPATH |
| 17 | Proposed Footpath |
| 18 | Road markings |
| 19 | Bollards |
| 20 | Cycle Stand |
| 21 | Proposed Light Pole |
| 22 | Signage board on light pole |
| 23 | Pedestrian Light on light pole |
| 24 | Proposed Seating on street |
| 25 | Additional paved area |
| 26 | Vending kiosks |
| 27 | Bus Box |

| NO | ISSUED FOR | DATE | CHKD |
|----|------------|------|------|
| | | | |

PROJECT NAME
UDAIPUR- AN URBAN95 CITY PHASE II

CLIENT NAME
ICLEI-Local Governments for Sustainability South Asia

TITLE
UDAIPUR CFC PHASE-II

NORTH

PROJECT UD-CFCII-22
SCALE 1:250
DRAWN BY MD SADAF HUSSAIN
DATE May 05, 2023

SHEET NUMBER
A3-1-09
C:creative footprints

RFP for Development of three Child and Family-friendly junctions and 1.5km Connected shared Street at Saheli Marg and Big Bazar Rd, Udaipur, Rajasthan

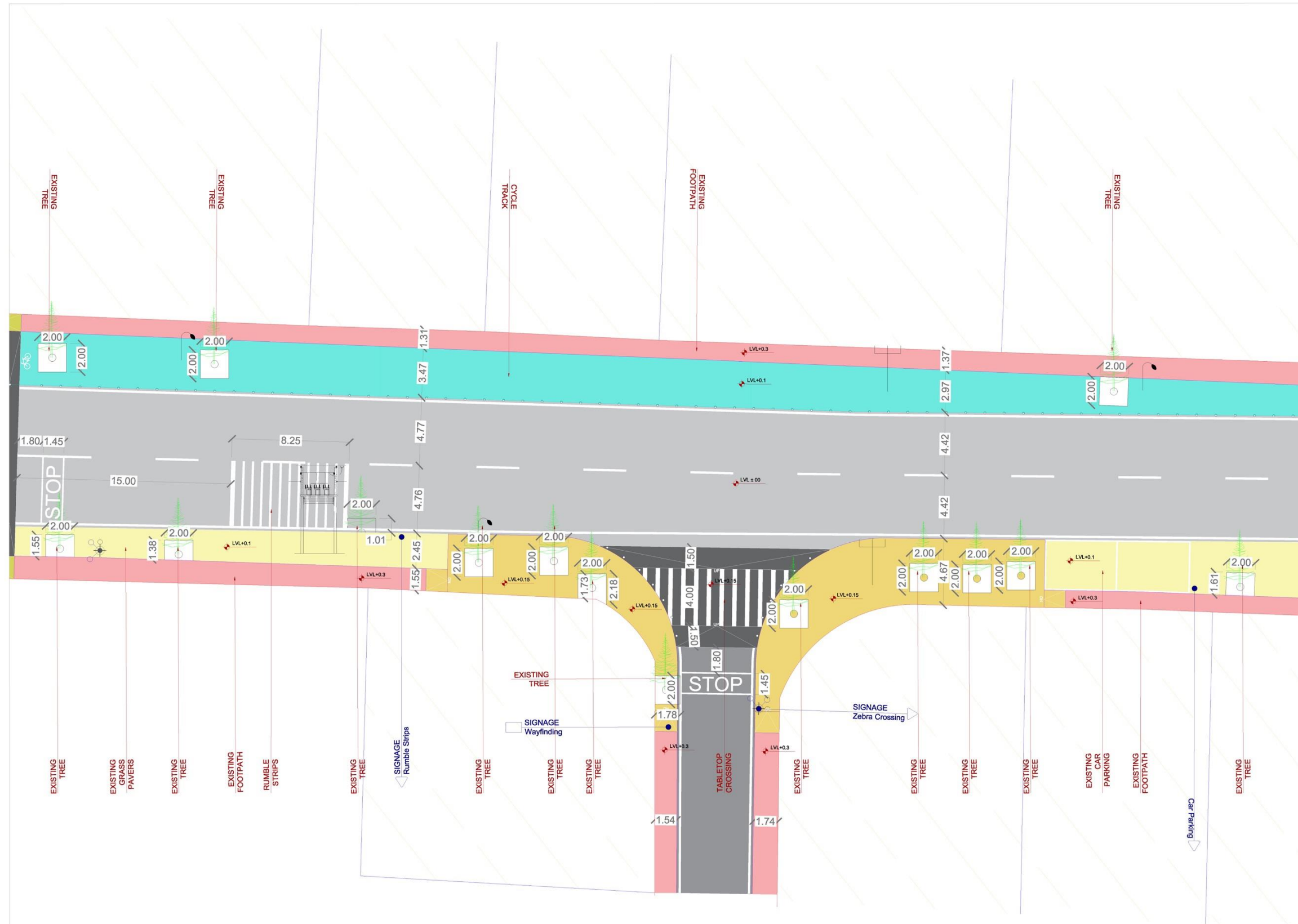

Supported By City Partner

Technical Partner

Drawings Made By

CREATIVE FOOTPRINTS
Architects | Planners | Designers

40/120, Ground Floor, Chittaranjan Park
New Delhi - 110019
Tel: 7042758806
Email: bigfoot@creativefootprints.co.in
Website: www.creativefootprints.co.in

- LEGEND: EXISTING FEATURES**
- Building / Hut / Tin shed
 - Electric / Telephone Pole
 - Light / Signal / Height sensor pole
 - Tree / H.P. / Well / Tube Well /
 - Boundary Wall
 - Kacchi Boundary / Thore Fencing
 - B.T. Road / Kaccha Rasta
 - Culvert / Bridge
 - Temple/Garden / Nallah
 - Property Line / boundary
 - Khasra Line & Khasra no.
 - Contour Line / Value
 - 500.00 Reduce Level
 - Dimension
- LEGEND: PROPOSED FEATURES**
- Existing Carriageway Line
 - EXISTING FOOTPATH
 - Proposed Footpath
 - Road markings
 - Bollards
 - Cycle Stand
 - Proposed Light Pole
 - Signage board on light pole
 - Pedestrian Light on light pole
 - Proposed Seating on street
 - Additional paved area
 - Vending kiosks
 - Bus Box

| NO | ISSUED FOR | DATE | CHKD |
|----|------------|------|------|
| | | | |

PROJECT NAME
UDAIPUR- AN URBAN95 CITY PHASE II

CLIENT NAME
ICLEI-Local Governments for Sustainability South Asia

TITLE
UDAIPUR CFC PHASE-II

NORTH

PROJECT UD-CFCII-22
SCALE 1:250
DRAWN BY MD SADAF HUSSAIN
DATE May 05, 2023

SHEET NUMBER
A3-1-10

© creative footprints

RFP for Development of three Child and Family-friendly junctions and 1.5km Connected shared Street at Saheli Marg and Big Bazar Rd, Udaipur, Rajasthan

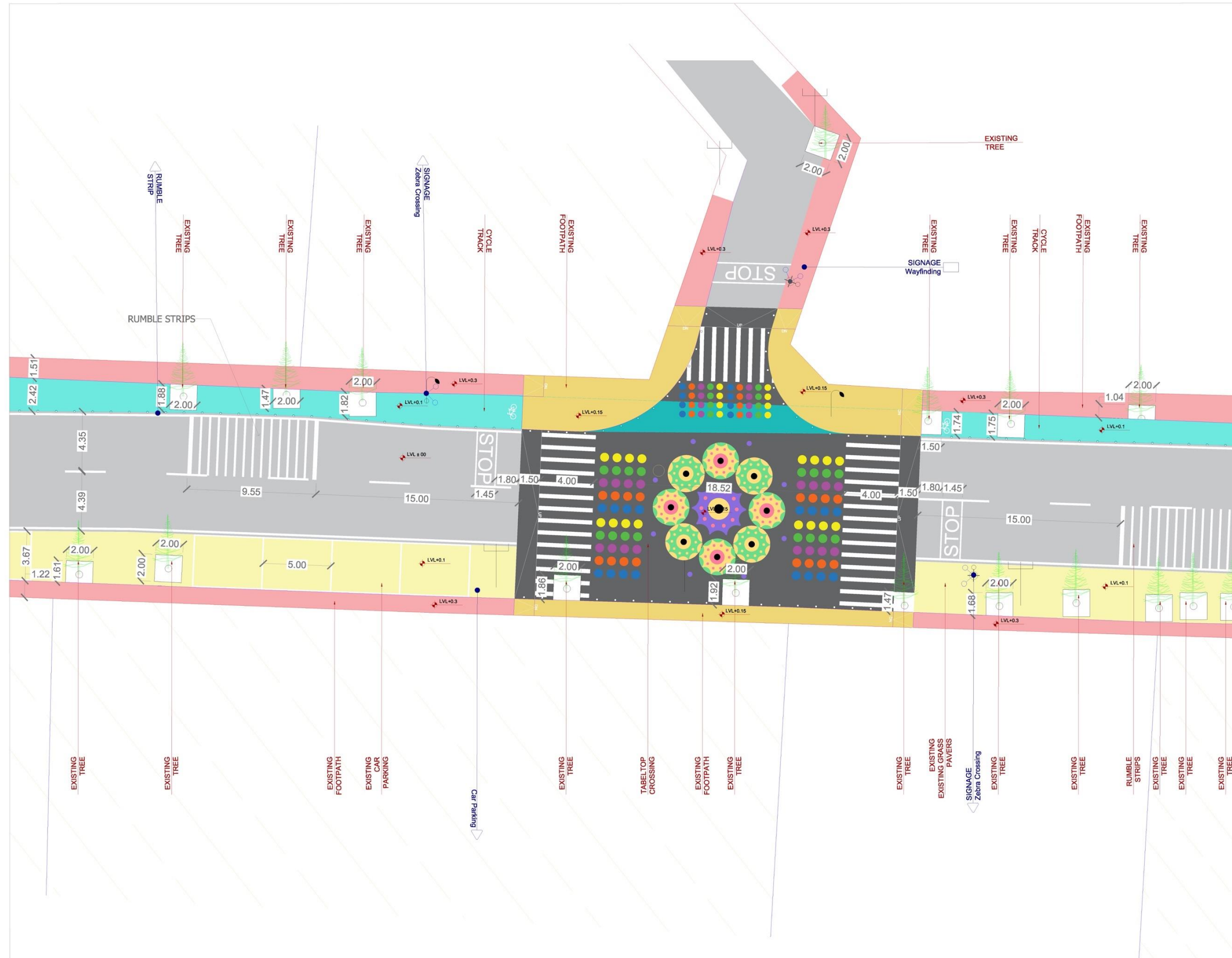

Supported By City Partner
 Bernard van Leer FOUNDATION
 Technical Partner
 ICLEI
 Local Governments for Sustainability
 Drawings Made By
 CREATIVE FOOTPRINTS
 Architects | Planners | Designers
 40/120, Ground Floor, Chittaranjan Park
 New Delhi - 110019
 Tel: 7042758806
 Email: bigfoot@creativefootprints.co.in
 Website: www.creativefootprints.co.in

LEGEND-EXISTING FEATURES

| | |
|----|-------------------------------------|
| 1 | Building / Hut / Tin shed |
| 2 | Electric / Tellophone Poll |
| 3 | Light / Signal / Heightenation poll |
| 4 | Tree / H.P./ Well / Tube Well / |
| 5 | Boundary Wall |
| 6 | Kacchi Boundary / Thore Fencing |
| 7 | B.T. Road /Kaccha Rasta |
| 8 | Culvert / Bridge |
| 9 | Temple/Garden / Nallaha |
| 10 | Property Line / boundary |
| 11 | k.no.552/Khasra Line & Khasra no. |
| 12 | Contour Line / Value |
| 13 | 500.00 Reduce Level |
| 14 | Dimension |

LEGEND-PROPOSED FEATURES

| | |
|----|--------------------------------|
| 15 | Existing Carriageway Line |
| 16 | EXISTING FOOTPATH |
| 17 | Proposed Footpath |
| 18 | Road markings |
| 19 | Bollards |
| 20 | Cycle Stand |
| 21 | Proposed Light Pole |
| 22 | Signage board on light pole |
| 23 | Pedestrian Light on light pole |
| 24 | Proposed Seating on street |
| 25 | Additional paved area |
| 26 | Vending kiosks |
| 27 | Bus Box |

| NO | ISSUED FOR | DATE | CHKD |
|----|------------|------|------|
| | | | |

PROJECT NAME
 UDAIPUR- AN URBAN95 CITY PHASE II

CLIENT NAME
 ICLEI-Local Governments for Sustainability South Asia

TITLE
 UDAIPUR CFC PHASE-II

 NORTH

PROJECT UD-CFCII-22
 SCALE 1:250
 DRAWN BY MD SADAF HUSSAIN
 DATE May 05, 2023

SHEET NUMBER
A3-1-11
 C:creative footprints

RFP for Development of three Child and Family-friendly junctions and 1.5km Connected shared Street at Saheli Marg and Big Bazar Rd, Udaipur, Rajasthan

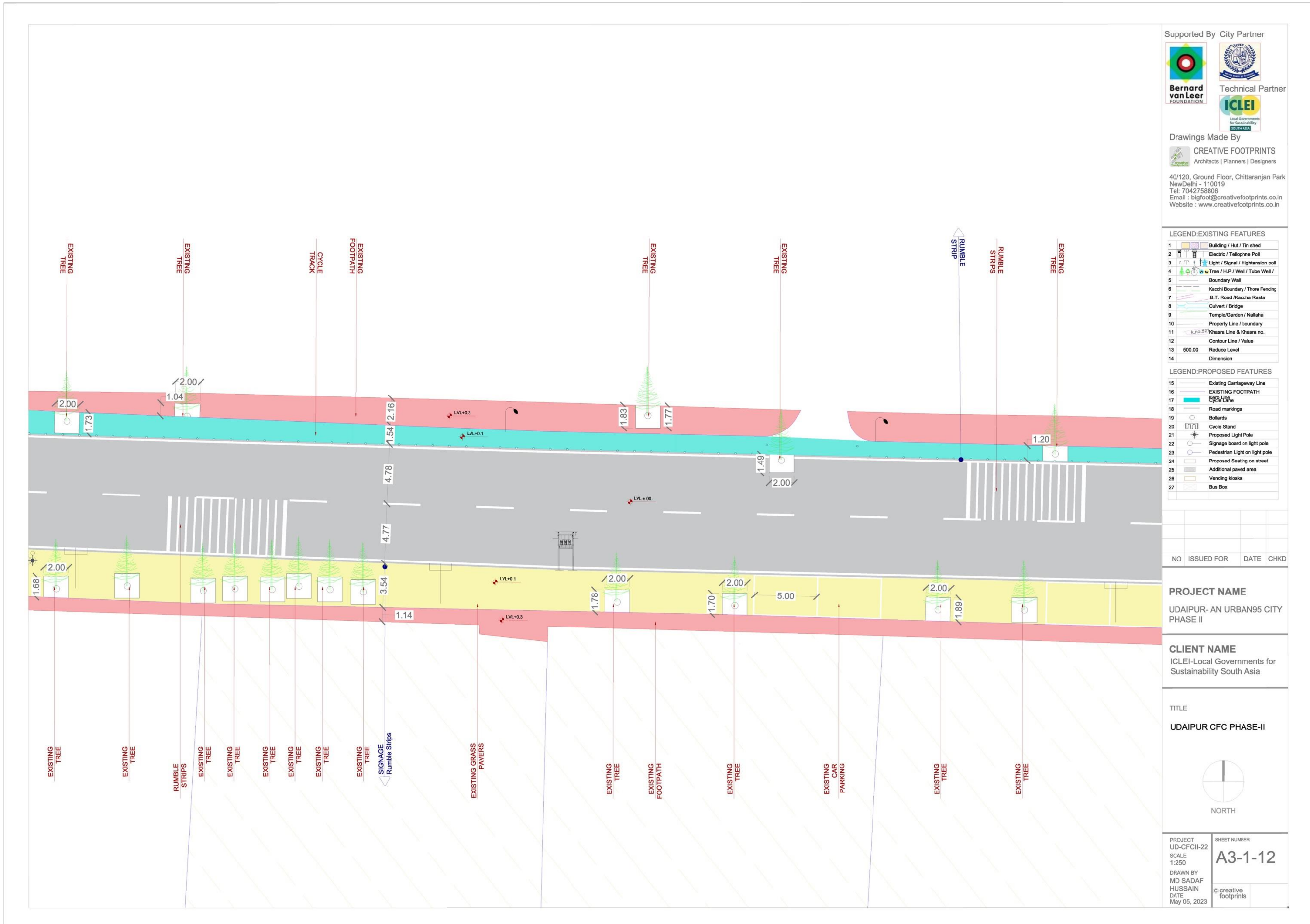

Supported By City Partner



Drawings Made By

CREATIVE FOOTPRINTS
Architects | Planners | Designers

40/120, Ground Floor, Chittaranjan Park
New Delhi - 110019
Tel: 7042758806
Email: bigfoot@creativefootprints.co.in
Website: www.creativefootprints.co.in

LEGEND: EXISTING FEATURES

| | |
|----|-------------------------------------|
| 1 | Building / Hut / Tin shed |
| 2 | Electric / Telephone Pole |
| 3 | Light / Signal / Height sensor pole |
| 4 | Tree / H.P. / Well / Tube Well / |
| 5 | Boundary Wall |
| 6 | Kacchi Boundary / Thore Fencing |
| 7 | B.T. Road / Kaccha Rasta |
| 8 | Culvert / Bridge |
| 9 | Temple/Garden / Nallaha |
| 10 | Property Line / boundary |
| 11 | K.no.5/2/ Khasra Line & Khasra no. |
| 12 | Contour Line / Value |
| 13 | 500.00 Reduce Level |
| 14 | Dimension |

LEGEND: PROPOSED FEATURES

| | |
|----|--------------------------------|
| 15 | Existing Carriageway Line |
| 16 | EXISTING FOOTPATH |
| 17 | Proposed Footpath |
| 18 | Road markings |
| 19 | Bollards |
| 20 | Cycle Stand |
| 21 | Proposed Light Pole |
| 22 | Signage board on light pole |
| 23 | Pedestrian Light on light pole |
| 24 | Proposed Seating on street |
| 25 | Additional paved area |
| 26 | Vending kiosks |
| 27 | Bus Box |

| NO | ISSUED FOR | DATE | CHKD |
|----|------------|------|------|
| | | | |

PROJECT NAME
UDAIPUR- AN URBAN95 CITY PHASE II

CLIENT NAME
ICLEI-Local Governments for Sustainability South Asia

TITLE
UDAIPUR CFC PHASE-II



| | |
|---------------------------|-----------------------|
| PROJECT UD-CFCII-22 | SHEET NUMBER |
| SCALE 1:250 | A3-1-12 |
| DRAWN BY MD SADAF HUSSAIN | © creative footprints |
| DATE May 05, 2023 | |

RFP for Development of three Child and Family-friendly junctions and 1.5km Connected shared Street at Saheli Marg and Big Bazar Rd, Udaipur, Rajasthan

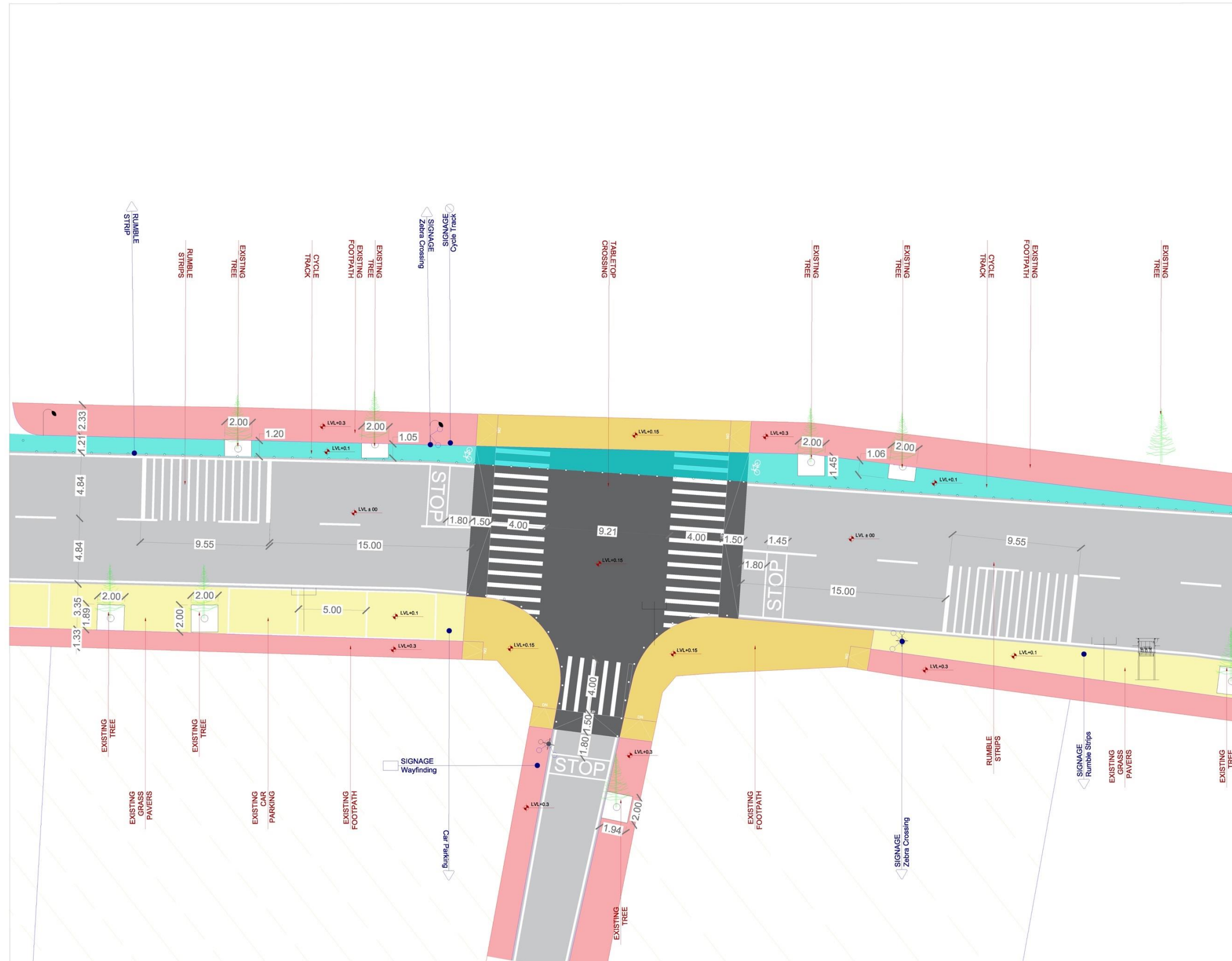

Supported By City Partner

Bernard van Leer FOUNDATION

Technical Partner
ICLEI
Local Governments for Sustainability

Drawings Made By
CREATIVE FOOTPRINTS
Architects | Planners | Designers

40/120, Ground Floor, Chittaranjan Park
New Delhi - 110019
Tel: 7042758806
Email: bigfoot@creativefootprints.co.in
Website: www.creativefootprints.co.in

LEGEND-EXISTING FEATURES

| | |
|----|-------------------------------------|
| 1 | Building / Hut / Tin shed |
| 2 | Electric / Tellophone Pole |
| 3 | Light / Signal / Heightenation pole |
| 4 | Tree / H.P./ Well / Tube Well / |
| 5 | Boundary Wall |
| 6 | Kacchi Boundary / Thore Fencing |
| 7 | B.T. Road /Kaccha Rasta |
| 8 | Culvert / Bridge |
| 9 | Temple/Garden / Nallaha |
| 10 | Property Line / boundary |
| 11 | Khasra Line & Khasra no. |
| 12 | Contour Line / Value |
| 13 | 500.00 Reduce Level |
| 14 | Dimension |

LEGEND-PROPOSED FEATURES

| | |
|----|--------------------------------|
| 15 | Existing Carriageway Line |
| 16 | EXISTING FOOTPATH |
| 17 | Proposed Footpath |
| 18 | Road markings |
| 19 | Bollards |
| 20 | Cycle Stand |
| 21 | Proposed Light Pole |
| 22 | Signage board on light pole |
| 23 | Pedestrian Light on light pole |
| 24 | Proposed Seating on street |
| 25 | Additional paved area |
| 26 | Vending kiosks |
| 27 | Bus Box |

| | | | |
|--|-----------------------|------|------|
| NO | ISSUED FOR | DATE | CHKD |
| | | | |
| PROJECT NAME | | | |
| UDAIPUR- AN URBAN95 CITY PHASE II | | | |
| CLIENT NAME | | | |
| ICLEI-Local Governments for Sustainability South Asia | | | |
| TITLE | | | |
| UDAIPUR CFC PHASE-II | | | |
|  NORTH | | | |
| PROJECT UD-CFCII-22 | SHEET NUMBER | | |
| SCALE 1:250 | A3-1-13 | | |
| DRAWN BY MD SADAF HUSSAIN | C:creative footprints | | |
| DATE May 05, 2023 | | | |

RFP for Development of three Child and Family-friendly junctions and 1.5km Connected shared Street at Saheli Marg and Big Bazar Rd, Udaipur, Rajasthan

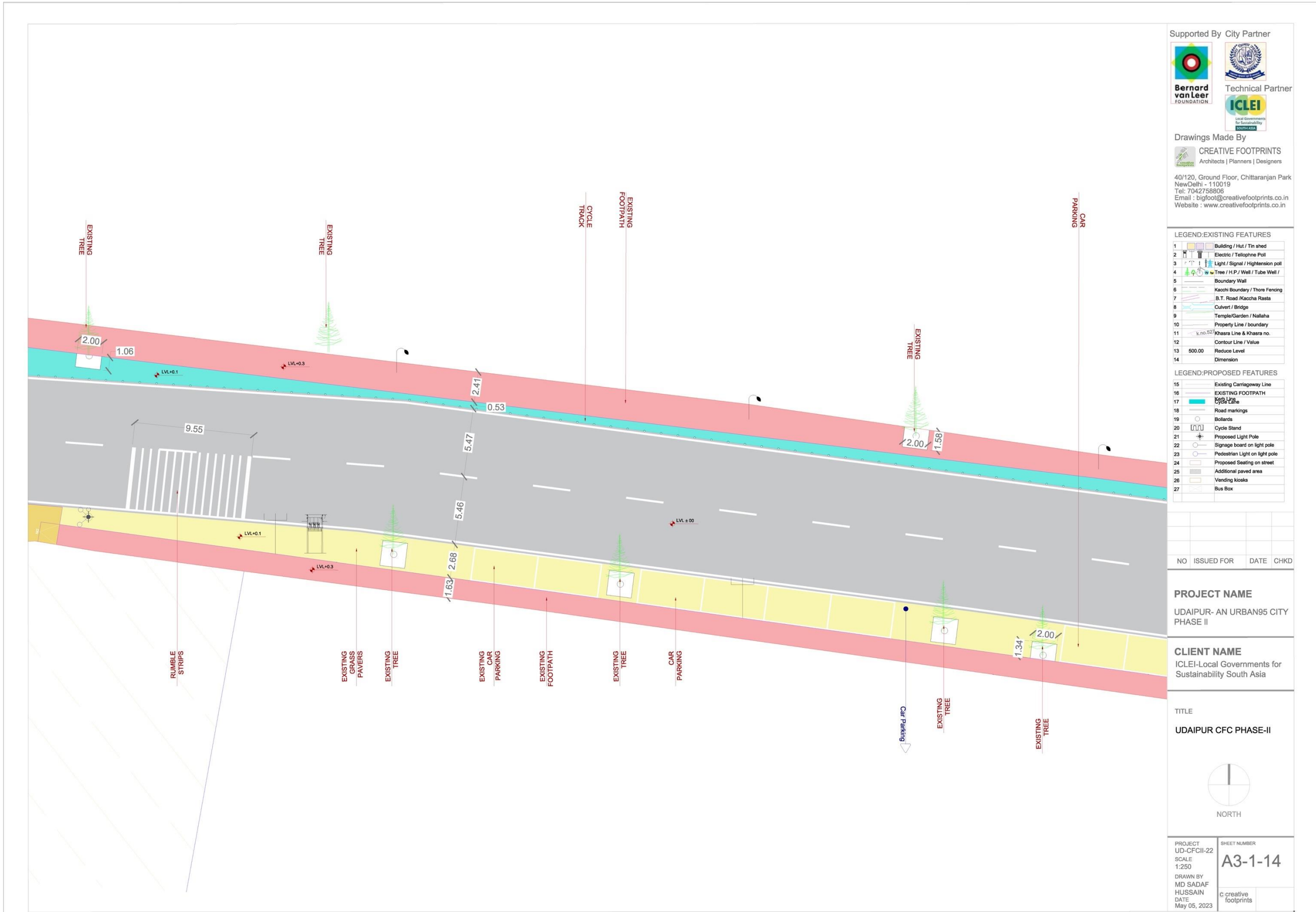

Supported By City Partner

Technical Partner
ICLEI
Local Governments for Sustainability

Drawings Made By
CREATIVE FOOTPRINTS
Architects | Planners | Designers

40/120, Ground Floor, Chittaranjan Park
New Delhi - 110019
Tel: 7042758806
Email: bigfoot@creativefootprints.co.in
Website: www.creativefootprints.co.in

LEGEND: EXISTING FEATURES

| | |
|----|------------------------------------|
| 1 | Building / Hut / Tin shed |
| 2 | Electric / Telephne Poll |
| 3 | Light / Signal / Heightension poll |
| 4 | Tree / H.P./ Well / Tube Well / |
| 5 | Boundary Wall |
| 6 | Kacchi Boundary / Thore Fencing |
| 7 | B.T. Road /Kaccha Rasta |
| 8 | Culvert / Bridge |
| 9 | Temple/Garden / Nallaha |
| 10 | Property Line / boundary |
| 11 | k.no.552 Khasra Line & Khasra no. |
| 12 | Contour Line / Value |
| 13 | 500.00 Reduce Level |
| 14 | Dimension |

LEGEND: PROPOSED FEATURES

| | |
|----|--------------------------------|
| 15 | Existing Carriageway Line |
| 16 | EXISTING FOOTPATH |
| 17 | Proposed Footpath |
| 18 | Road markings |
| 19 | Bollards |
| 20 | Cycle Stand |
| 21 | Proposed Light Pole |
| 22 | Signage board on light pole |
| 23 | Pedestrian Light on light pole |
| 24 | Proposed Seating on street |
| 25 | Additional paved area |
| 26 | Vending kiosks |
| 27 | Bus Box |

| NO | ISSUED FOR | DATE | CHKD |
|----|------------|------|------|
| | | | |

PROJECT NAME
UDAIPUR- AN URBAN95 CITY PHASE II

CLIENT NAME
ICLEI-Local Governments for Sustainability South Asia

TITLE
UDAIPUR CFC PHASE-II



| | |
|------------------------------|--------------------------------|
| PROJECT UD-CFCII-22 | SHEET NUMBER A3-1-14 |
| SCALE 1:250 | |
| DRAWN BY MD SADAF HUSSAIN | |
| DATE May 05, 2023 | C:creative footprints |

RFP for Development of three Child and Family-friendly junctions and 1.5km Connected shared Street at Saheli Marg and Big Bazar Rd, Udaipur, Rajasthan

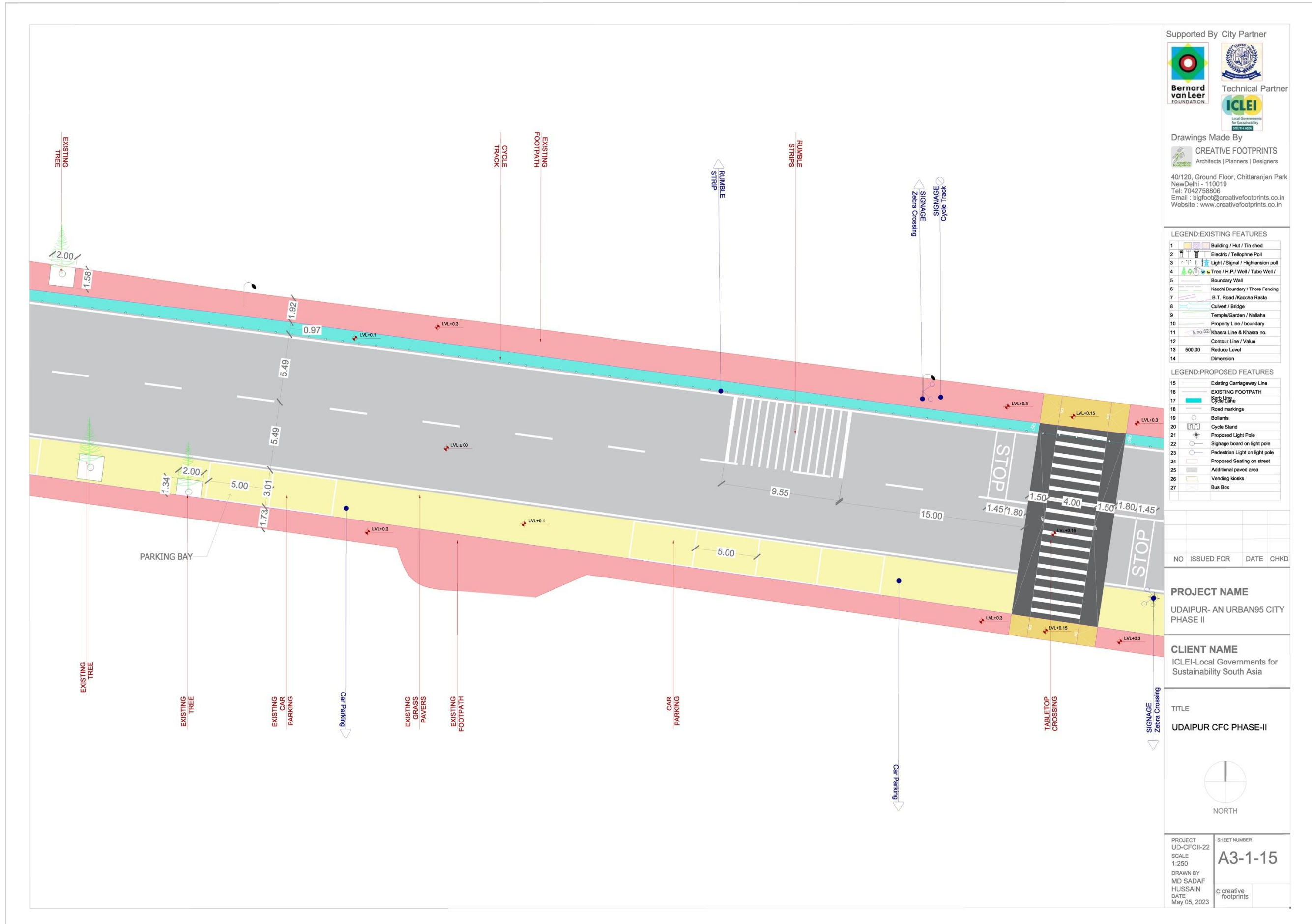

Supported By City Partner

Bernard van Leer FOUNDATION

Technical Partner

ICLEI
Local Governments for Sustainability

Drawings Made By

CREATIVE FOOTPRINTS
Architects | Planners | Designers

40/120, Ground Floor, Chittaranjan Park
New Delhi - 110019
Tel: 7042758806
Email: bigfoot@creativefootprints.co.in
Website: www.creativefootprints.co.in

LEGEND: EXISTING FEATURES

| | |
|----|------------------------------------|
| 1 | Building / Hut / Tin shed |
| 2 | Electric / Telephone Pole |
| 3 | Light / Signal / Heightension pole |
| 4 | Tree / H.P./ Well / Tube Well / |
| 5 | Boundary Wall |
| 6 | Kacchi Boundary / Thore Fencing |
| 7 | B.T. Road /Kaccha Rasta |
| 8 | Culvert / Bridge |
| 9 | Temple/Garden / Nallah |
| 10 | Property Line / boundary |
| 11 | K.no.52/ Khasra Line & Khasra no. |
| 12 | Contour Line / Value |
| 13 | 500.00 Reduce Level |
| 14 | Dimension |

LEGEND: PROPOSED FEATURES

| | |
|----|--------------------------------|
| 15 | Existing Carriageway Line |
| 16 | EXISTING FOOTPATH |
| 17 | Proposed Footpath |
| 18 | Road markings |
| 19 | Bollards |
| 20 | Cycle Stand |
| 21 | Proposed Light Pole |
| 22 | Signage board on light pole |
| 23 | Pedestrian Light on light pole |
| 24 | Proposed Seating on street |
| 25 | Additional paved area |
| 26 | Vending kiosks |
| 27 | Bus Box |

| NO | ISSUED FOR | DATE | CHKD |
|----|------------|------|------|
| | | | |

PROJECT NAME
UDAIPUR- AN URBAN95 CITY PHASE II

CLIENT NAME
ICLEI-Local Governments for Sustainability South Asia

TITLE
UDAIPUR CFC PHASE-II

NORTH

PROJECT UD-CFCII-22
SCALE 1:250
DRAWN BY MD SADAF HUSSAIN
DATE May 05, 2023

SHEET NUMBER
A3-1-15
C creative footprints

RFP for Development of three Child and Family-friendly junctions and 1.5km Connected shared Street at Saheli Marg and Big Bazar Rd, Udaipur, Rajasthan

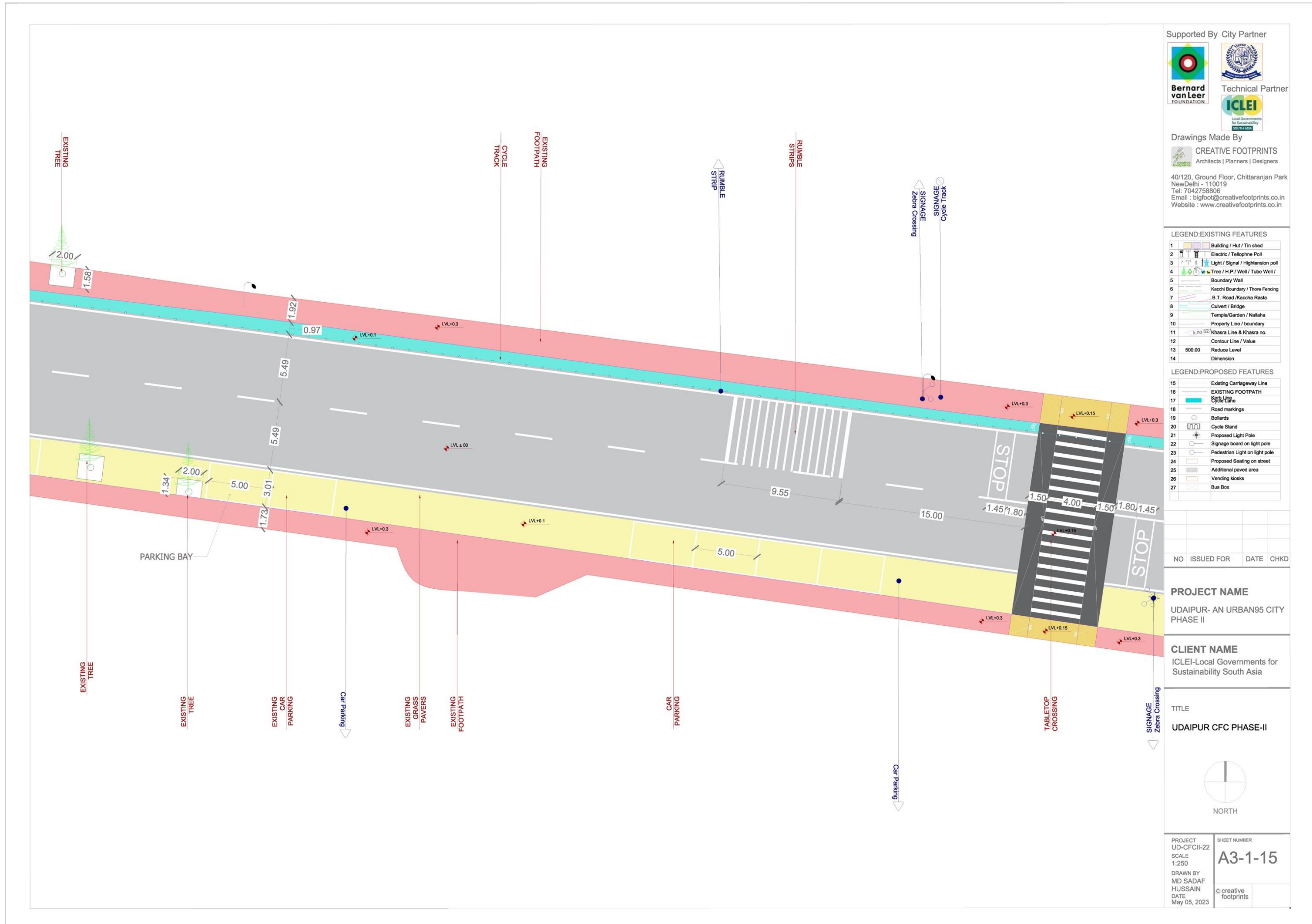

Supported By City Partner

Bernard van Leer FOUNDATION

Technical Partner

ICLEI
Local Governments for Sustainability

Drawings Made By

CREATIVE FOOTPRINTS
Architects | Planners | Designers

40/120, Ground Floor, Chittaranjan Park
New Delhi - 110019
Tel: 7042758806
Email: bigfoot@creativefootprints.co.in
Website: www.creativefootprints.co.in

LEGEND: EXISTING FEATURES

| | |
|----|------------------------------------|
| 1 | Building / Hut / Tin shed |
| 2 | Electric / Telephone Pole |
| 3 | Light / Signal / Heightension pole |
| 4 | Tree / H.P./ Well / Tube Well / |
| 5 | Boundary Wall |
| 6 | Kacchi Boundary / Thore Fencing |
| 7 | B.T. Road /Kaccha Rasta |
| 8 | Culvert / Bridge |
| 9 | Temple/Garden / Nallah |
| 10 | Property Line / boundary |
| 11 | K.no.52/ Khasra Line & Khasra no. |
| 12 | Contour Line / Value |
| 13 | 500.00 Reduce Level |
| 14 | Dimension |

LEGEND: PROPOSED FEATURES

| | |
|----|--------------------------------|
| 15 | Existing Carriageway Line |
| 16 | EXISTING FOOTPATH |
| 17 | Proposed Footpath |
| 18 | Road markings |
| 19 | Bollards |
| 20 | Cycle Stand |
| 21 | Proposed Light Pole |
| 22 | Signage board on light pole |
| 23 | Pedestrian Light on light pole |
| 24 | Proposed Seating on street |
| 25 | Additional paved area |
| 26 | Vending kiosks |
| 27 | Bus Box |

| NO | ISSUED FOR | DATE | CHKD |
|----|------------|------|------|
| | | | |

PROJECT NAME
UDAIPUR- AN URBAN95 CITY PHASE II

CLIENT NAME
ICLEI-Local Governments for Sustainability South Asia

TITLE
UDAIPUR CFC PHASE-II

NORTH

PROJECT UD-CFCII-22
SCALE 1:250
DRAWN BY MD SADAF HUSSAIN
DATE May 05, 2023

SHEET NUMBER
A3-1-15
C creative footprints

RFP for Development of three Child and Family-friendly junctions and 1.5km Connected shared Street at Saheli Marg and Big Bazar Rd, Udaipur, Rajasthan



Supported By City Partner

Bernard van Leer FOUNDATION

Technical Partner

ICLEI Local Governments for Sustainability

Drawings Made By

CREATIVE FOOTPRINTS Architects | Planners | Designers

40/120, Ground Floor, Chittaranjan Park NewDelhi - 110019
Tel: 7042758806
Email: bigfoot@creativefootprints.co.in
Website: www.creativefootprints.co.in

LEGEND-EXISTING FEATURES

| | |
|----|-----------------------------------|
| 1 | Building / Hut / Tin shed |
| 2 | Electric / Telegraph Pole |
| 3 | Light / Signal / Heighten pole |
| 4 | Tree / H.P./ Well / Tube Well / |
| 5 | Boundary Wall |
| 6 | Kacchi Boundary / Thore Fencing |
| 7 | B.T. Road /Kaccha Rasta |
| 8 | Culvert / Bridge |
| 9 | Temple/Garden / Nallah |
| 10 | Property Line / boundary |
| 11 | K.no.52/ Khassa Line & Khassa no. |
| 12 | Contour Line / Value |
| 13 | 500.00 Reduce Level |
| 14 | Dimension |

LEGEND-PROPOSED FEATURES

| | |
|----|--------------------------------|
| 15 | Existing Carriageway Line |
| 16 | EXISTING FOOTPATH |
| 17 | Proposed Footpath |
| 18 | Road markings |
| 19 | Bollards |
| 20 | Cycle Stand |
| 21 | Proposed Light Pole |
| 22 | Signage board on light pole |
| 23 | Pedestrian Light on light pole |
| 24 | Proposed Seating on street |
| 25 | Additional paved area |
| 26 | Vending kiosks |
| 27 | Bus Box |

| NO | ISSUED FOR | DATE | CHKD |
|----|------------|------|------|
| | | | |

PROJECT NAME
UDAIPUR- AN URBAN95 CITY PHASE II

CLIENT NAME
ICLEI-Local Governments for Sustainability South Asia

TITLE
UDAIPUR CFC PHASE-II

NORTH

PROJECT UD-CFCII-22
SCALE 1:250
DRAWN BY MD SADAF HUSSAIN
DATE May 05, 2023

SHEET NUMBER
A3-1-19
C creative footprints

RFP for Development of three Child and Family-friendly junctions and 1.5km Connected shared Street at Saheli Marg and Big Bazar Rd, Udaipur, Rajasthan

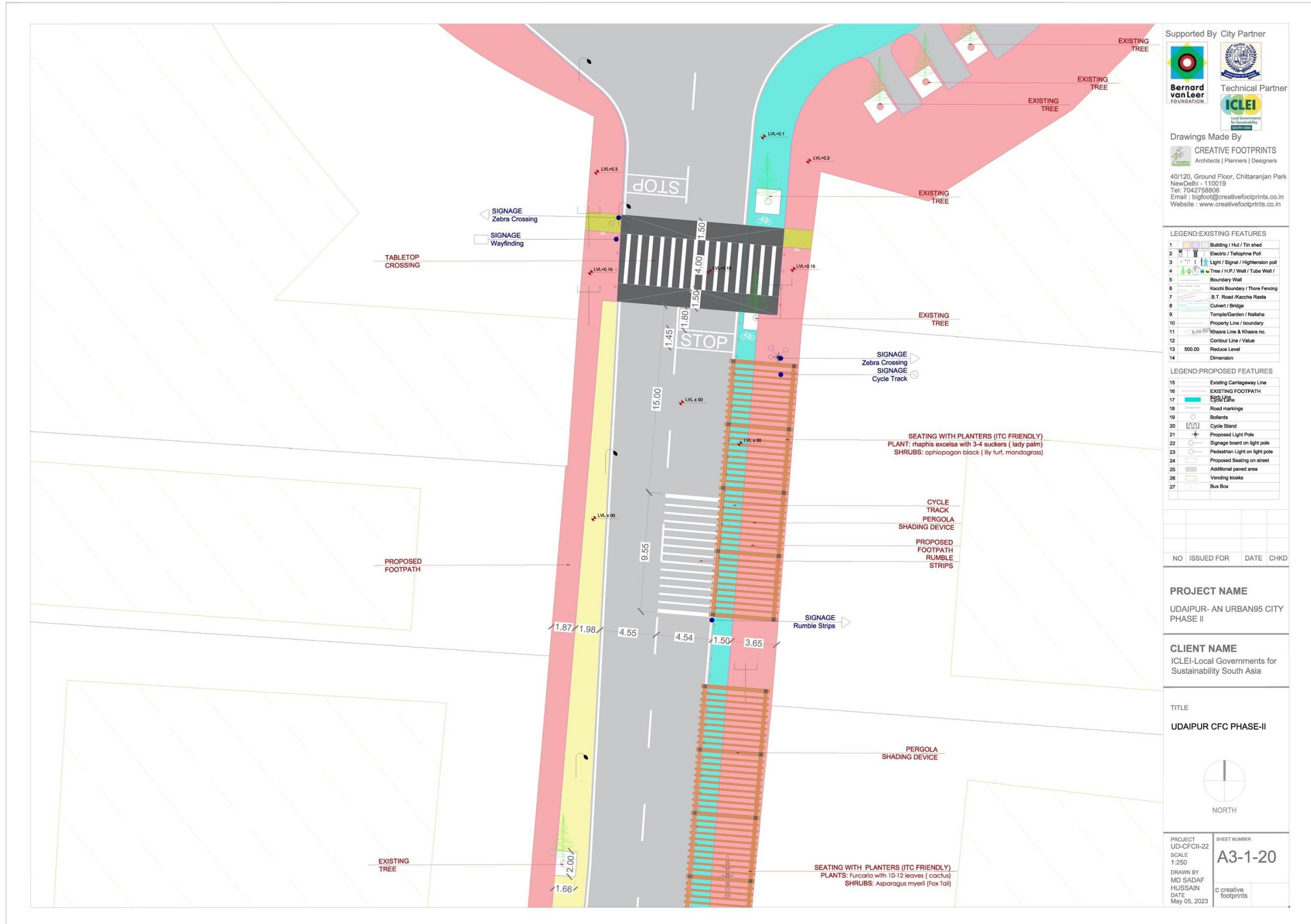

Supported By City Partner

 Bernard van Leer FOUNDATION

 Technical Partner
 ICLEI
 Local Governments for Sustainability
 Drawings Made By

 CREATIVE FOOTPRINTS
 Architects | Planners | Designers
 40/120, Ground Floor, Chittaranjan Park
 New Delhi - 110019
 Tel: 7042758806
 Email: bigfoot@creativefootprints.co.in
 Website: www.creativefootprints.co.in

LEGEND: EXISTING FEATURES

| | |
|----|------------------------------------|
| 1 | Building / Hut / Tin shed |
| 2 | Electric / Telephone Pole |
| 3 | Light / Signal / High tension pole |
| 4 | Tree / H.P. / Well / Tube Well / |
| 5 | Boundary Wall |
| 6 | Kaschi Boundary / Thore Fencing |
| 7 | B.T. Road / Kascha Rasta |
| 8 | Culvert / Bridge |
| 9 | Temple/Garden / Nallaha |
| 10 | Property Line / boundary |
| 11 | Khasra Line & Khasra no. |
| 12 | Contour Line / Value |
| 13 | 500.00 Reduce Level |
| 14 | Dimension |

LEGEND: PROPOSED FEATURES

| | |
|----|--------------------------------|
| 15 | Existing Carriageway Line |
| 16 | EXISTING FOOTPATH |
| 17 | Left Lane |
| 18 | Right Lane |
| 19 | Road markings |
| 20 | Bollards |
| 21 | Cycle Stand |
| 22 | Proposed Light Pole |
| 23 | Signage board on light pole |
| 24 | Pedestrian Light on light pole |
| 25 | Proposed Seating on street |
| 26 | Additional paved area |
| 27 | Vending kiosks |
| 28 | Bus Box |

| NO | ISSUED FOR | DATE | CHKD |
|----|------------|------|------|
| | | | |

PROJECT NAME
 UDAIPUR- AN URBAN95 CITY PHASE II

CLIENT NAME
 ICLEI-Local Governments for Sustainability South Asia

TITLE
 UDAIPUR CFC PHASE-II



PROJECT UD-CFCII-22
 SCALE 1:250
 DRAWN BY MD SADAF HUSSAIN
 DATE May 05, 2023

SHEET NUMBER
A3-1-20
 C creative footprints

RFP for Development of three Child and Family-friendly junctions and 1.5km Connected shared Street at Saheli Marg and Big Bazar Rd, Udaipur, Rajasthan

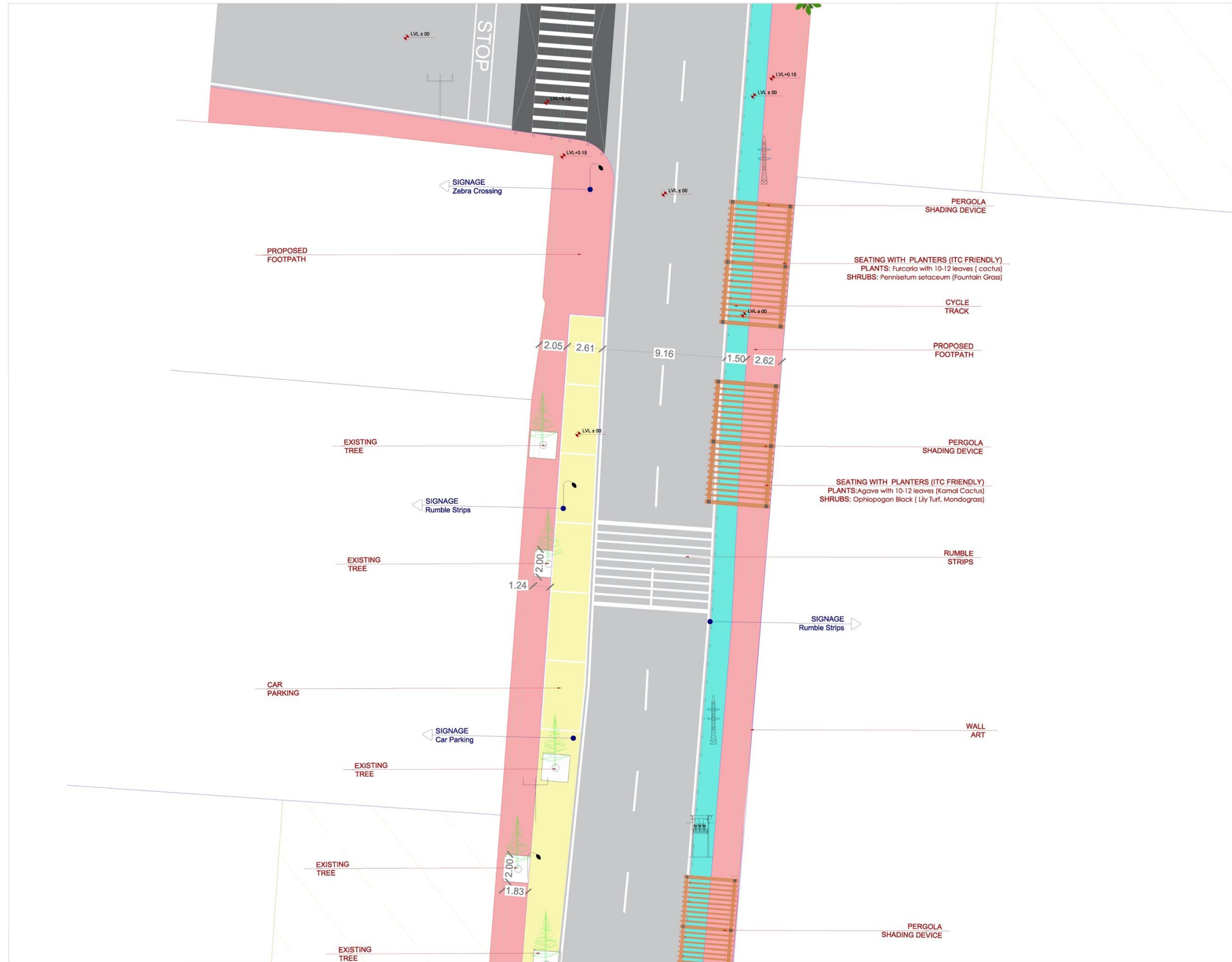

Supported By City Partner
 
 Technical Partner
 Drawings Made By
 CREATIVE FOOTPRINTS
 Architects | Planners | Designers
 40/120, Ground Floor, Chittaranjan Park
 New Delhi - 110019
 Tel: 7042758806
 Email: bigfoot@creativefootprints.co.in
 Website: www.creativefootprints.co.in

LEGEND: EXISTING FEATURES

| | |
|----|-----------------------------------|
| 1 | Building / Hut / Tin shed |
| 2 | Electric / Telephone Pole |
| 3 | Light / Signal / Heighten pole |
| 4 | Tree / H.P./ Well / Tube Well / |
| 5 | Boundary Wall |
| 6 | Kacchi Boundary / Thore Fencing |
| 7 | B.T. Road / Kaccha Rasta |
| 8 | Culvert / Bridge |
| 9 | Temple/Garden / Nalaha |
| 10 | Property Line / boundary |
| 11 | K.No.52/ Khassa Line & Khassa no. |
| 12 | Contour Line / Value |
| 13 | 500.00 Reduce Level |
| 14 | Dimension |

LEGEND: PROPOSED FEATURES

| | |
|----|--------------------------------|
| 15 | Existing Carriageway Line |
| 16 | EXISTING FOOTPATH |
| 17 | Proposed Footpath |
| 18 | Road markings |
| 19 | Bollards |
| 20 | Cycle Stand |
| 21 | Proposed Light Pole |
| 22 | Signage board on light pole |
| 23 | Pedestrian Light on light pole |
| 24 | Proposed Seating on street |
| 25 | Additional paved area |
| 26 | Vending kiosks |
| 27 | Bus Box |

| NO | ISSUED FOR | DATE | CHKD |
|----|------------|------|------|
| | | | |

PROJECT NAME
 UDAIPUR- AN URBAN95 CITY PHASE II

CLIENT NAME
 ICLEI-Local Governments for Sustainability South Asia

TITLE
 UDAIPUR CFC PHASE-II



| | |
|------------------------------|--------------------------------|
| PROJECT UD-CFCII-22 | SHEET NUMBER A3-1-22 |
| SCALE 1:250 | |
| DRAWN BY MD SADAF HUSSAIN | |
| DATE May 05, 2023 | |

RFP for Development of three Child and Family-friendly junctions and 1.5km Connected shared Street at Saheli Marg and Big Bazar Rd, Udaipur, Rajasthan

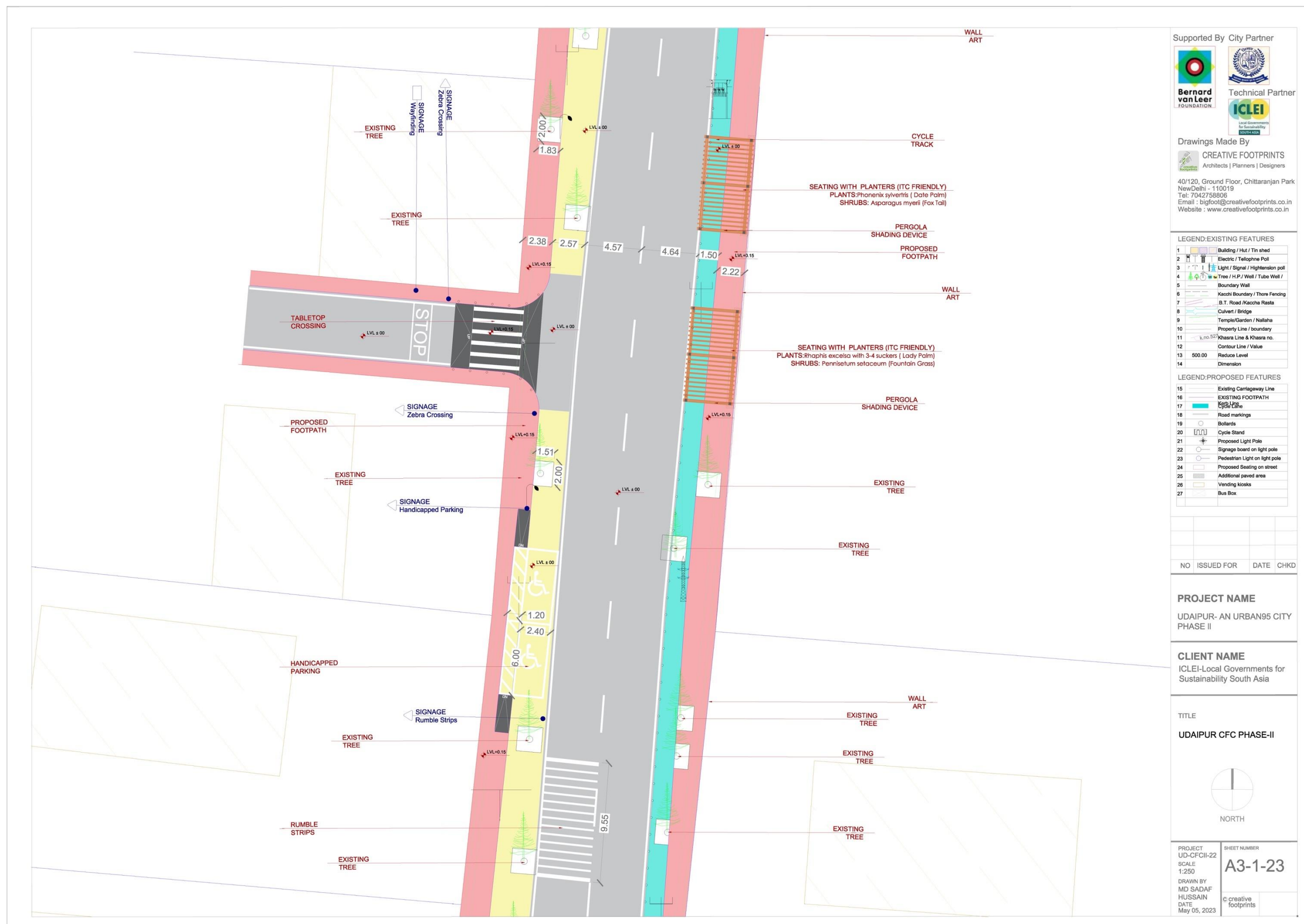

Supported By City Partner

Bernard van Leer FOUNDATION

Technical Partner

ICLEI Local Governments for Sustainability

Drawings Made By

CREATIVE FOOTPRINTS
Architects | Planners | Designers

40/120, Ground Floor, Chittaranjan Park
New Delhi - 110019
Tel: 7042758806
Email: bigfoot@creativefootprints.co.in
Website: www.creativefootprints.co.in

LEGEND: EXISTING FEATURES

| | |
|----|------------------------------------|
| 1 | Building / Hut / Tin shed |
| 2 | Electric / Telephone Pole |
| 3 | Light / Signal / High tension pole |
| 4 | Tree / H.P./ Well / Tube Well / |
| 5 | Boundary Wall |
| 6 | Kacchi Boundary / Thore Fencing |
| 7 | B.T. Road / Kaccha Rasta |
| 8 | Culvert / Bridge |
| 9 | Temple/Garden / Nallah |
| 10 | Property Line / boundary |
| 11 | K.no.55/ Khasra Line & Khasra no. |
| 12 | Contour Line / Value |
| 13 | 500.00 Reduce Level |
| 14 | Dimension |

LEGEND: PROPOSED FEATURES

| | |
|----|--------------------------------|
| 15 | Existing Carriageway Line |
| 16 | EXISTING FOOTPATH |
| 17 | Proposed Footpath |
| 18 | Road markings |
| 19 | Bollards |
| 20 | Cycle Stand |
| 21 | Proposed Light Pole |
| 22 | Signage board on light pole |
| 23 | Pedestrian Light on light pole |
| 24 | Proposed Seating on street |
| 25 | Additional paved area |
| 26 | Vending kiosks |
| 27 | Bus Box |

| NO | ISSUED FOR | DATE | CHKD |
|----|------------|------|------|
| | | | |

PROJECT NAME

UDAIPUR- AN URBAN95 CITY PHASE II

CLIENT NAME

ICLEI-Local Governments for Sustainability South Asia

TITLE

UDAIPUR CFC PHASE-II



PROJECT UD-CFCII-22
SCALE 1:250
DRAWN BY MD SADAF HUSSAIN
DATE May 05, 2023

SHEET NUMBER
A3-1-23
C creative footprints

RFP for Development of three Child and Family-friendly junctions and 1.5km Connected shared Street at Saheli Marg and Big Bazar Rd, Udaipur, Rajasthan

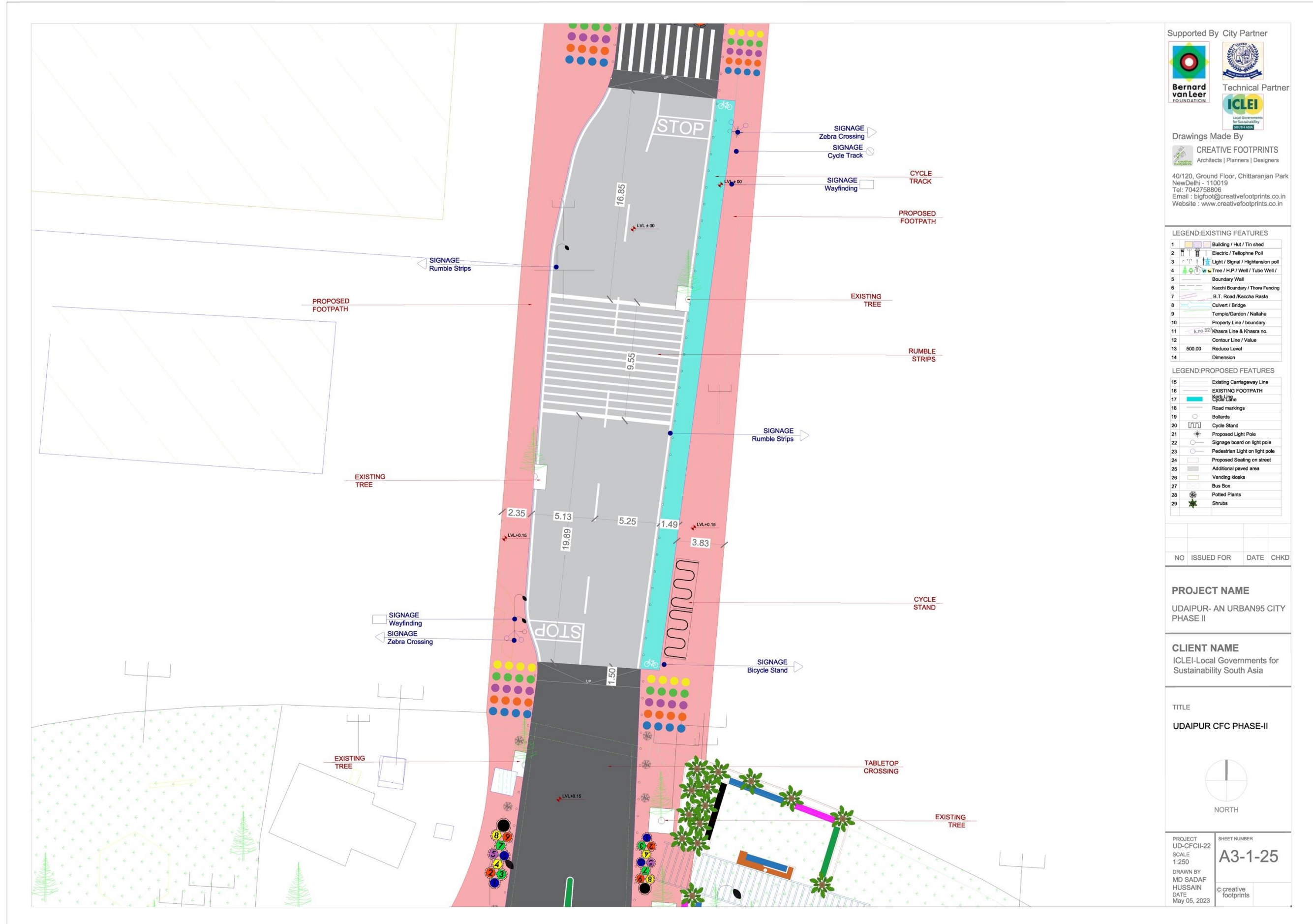

Supported By City Partner

Bernard van Leer FOUNDATION

Technical Partner
ICLEI
Local Governments for Sustainability

Drawings Made By
CREATIVE FOOTPRINTS
Architects | Planners | Designers

40/120, Ground Floor, Chittaranjan Park
New Delhi - 110019
Tel: 7042758806
Email: bigfoot@creativefootprints.co.in
Website: www.creativefootprints.co.in

LEGEND: EXISTING FEATURES

| | |
|----|------------------------------------|
| 1 | Building / Hut / Tin shed |
| 2 | Electric / Telephone Pole |
| 3 | Light / Signal / High tension pole |
| 4 | Tree / H.P./ Well / Tube Well / |
| 5 | Boundary Wall |
| 6 | Kacchi Boundary / Thore Fencing |
| 7 | B.T. Road / Kaccha Rasta |
| 8 | Culvert / Bridge |
| 9 | Temple/Garden / Nallaha |
| 10 | Property Line / boundary |
| 11 | K.no.52/ Khasra Line & Khasra no. |
| 12 | Contour Line / Value |
| 13 | 500.00 Reduce Level |
| 14 | Dimension |

LEGEND: PROPOSED FEATURES

| | |
|----|--------------------------------|
| 15 | Existing Carriageway Line |
| 16 | EXISTING FOOTPATH |
| 17 | Light Line |
| 18 | Road markings |
| 19 | Bollards |
| 20 | Cycle Stand |
| 21 | Proposed Light Pole |
| 22 | Signage board on light pole |
| 23 | Pedestrian Light on light pole |
| 24 | Proposed Seating on street |
| 25 | Additional paved area |
| 26 | Vending kiosks |
| 27 | Bus Box |
| 28 | Potted Plants |
| 29 | Shrubs |

| NO | ISSUED FOR | DATE | CHKD |
|----|------------|------|------|
| | | | |

PROJECT NAME
UDAIPUR- AN URBAN95 CITY PHASE II

CLIENT NAME
ICLEI-Local Governments for Sustainability South Asia

TITLE
UDAIPUR CFC PHASE-II



PROJECT UD-CFCII-22
SCALE 1:250
DRAWN BY MD SADAF HUSSAIN
DATE May 05, 2023

SHEET NUMBER
A3-1-25
© creative footprints

RFP for Development of three Child and Family-friendly junctions and 1.5km Connected shared Street at Saheli Marg and Big Bazar Rd, Udaipur, Rajasthan

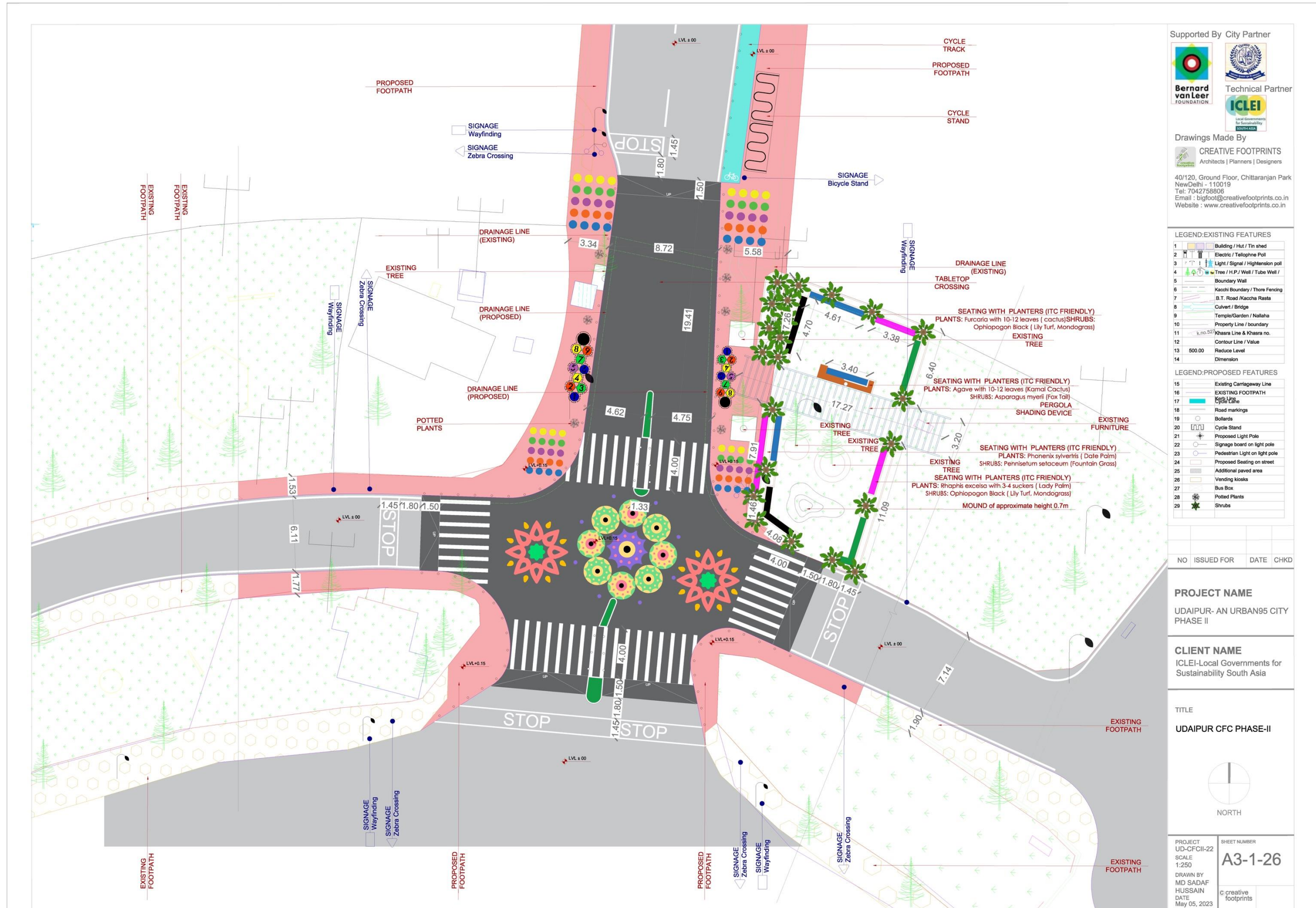

RFP for Development of three Child and Family-friendly junctions and 1.5km Connected shared Street at Saheli Marg and Big Bazar Rd, Udaipur, Rajasthan

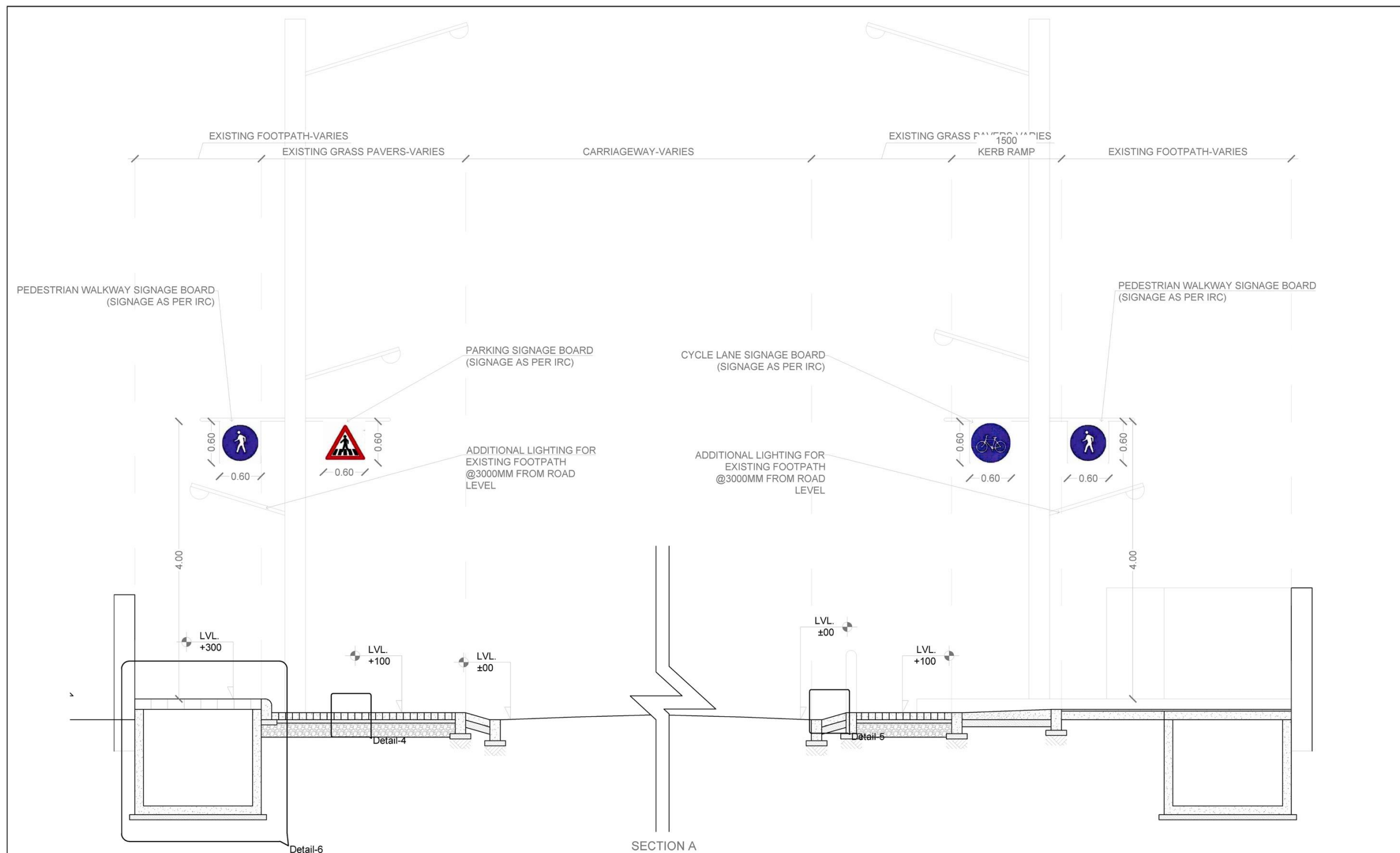

| | | | | | | | | | | | |
|-------------|-------|-------------|--|--|------------------|------------------|-----------------------|--|---|------------------|---------------------------------|
| Revision No | Dated | Description | Notes: Description 1. ALL DIMENSIONS ARE IN M 2. Any discrepancy noted at any stage and in any form is to be immediately brought to the notice of the architect. | Project Name : UDAIPUR- AN URBAN95 CITY PHASE II | Supported By | City Partner | Technical Partner | Design Made by: Creative Footprints 40/120, Ground Floor, Chittaranjan Park, New Delhi - 110019 Tel. : +91 7042758806 Email : bigfoot@creativefootprints.co.in Website : www.creativefootprints.co.in | Drawing Title: TYPICAL SECTIONS AND DETAILS FOR EXISTING FOOTPATH, KERB, TABLETOP CROSSING, BOLLARDS | Date: 05-03-2023 | Drawing No.: UD-CFCII-22-SEC-01 |
| | | | | Client Name : ICLEI-Local Governments for Sustainability South Asia | | | | | Drawn By: MD SADAF HUSSAIN | Scale: 1:50 @ A3 | |
| | | | | | | | | | Checked By: ADARSHA KAPOOR | Revision: | |

RFP for Development of three Child and Family-friendly junctions and 1.5km Connected shared Street at Saheli Marg and Big Bazar Rd, Udaipur, Rajasthan

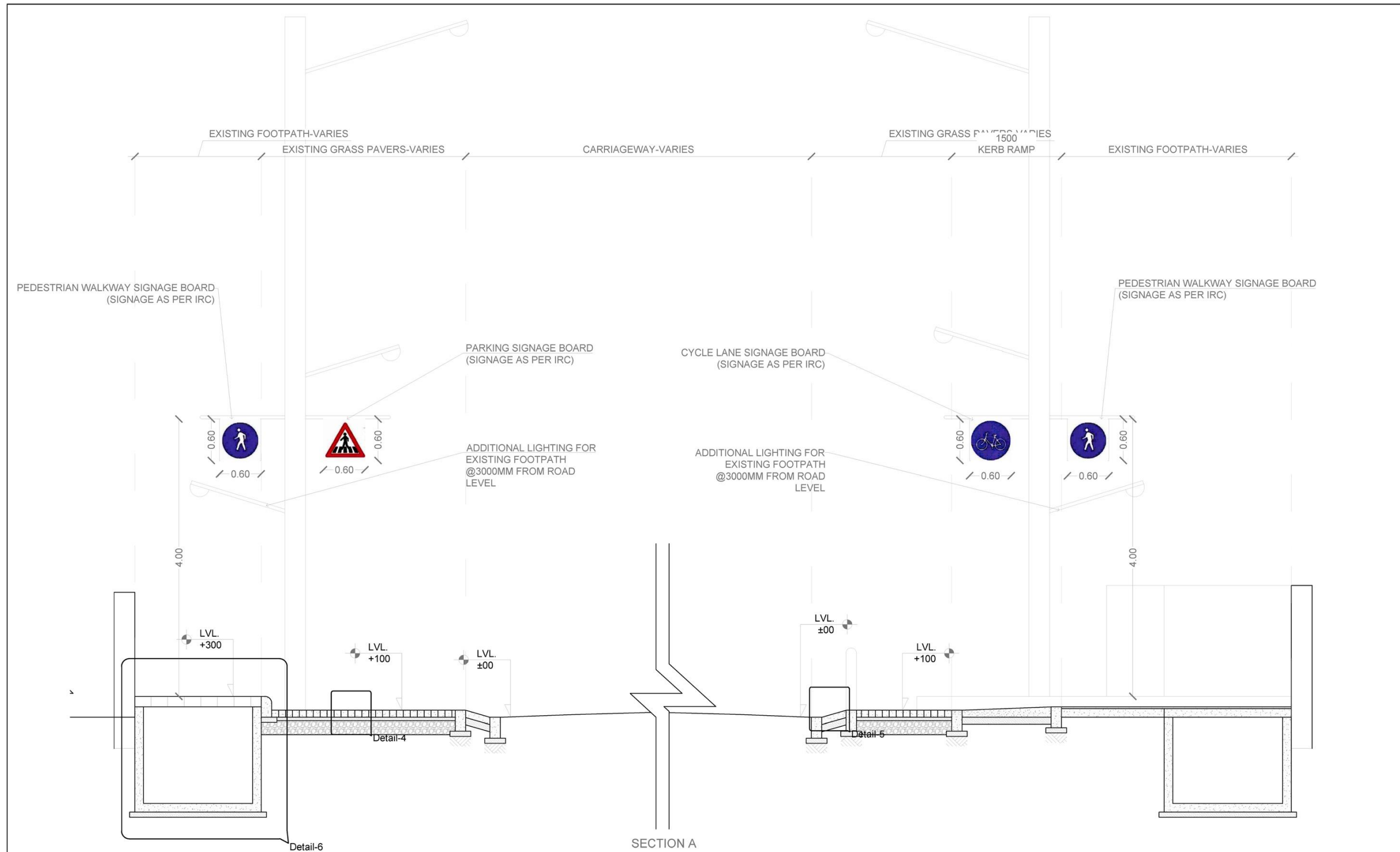

| Revision No | Dated | Description | Notes: | Description | Project Name : | Supported By | City Partner | Technical Partner | Design Made by: | Drawing Title: |
|-------------|-------|-------------|--|-------------|---|--------------|--------------|-------------------|--|---|
| | | | 1. ALL DIMENSIONS ARE IN M 2. Any discrepancy noted at any stage and in any form is to be immediately brought to the notice of the architect. | | UDAIPUR- AN URBAN95 CITY PHASE II | | | | | TYPICAL SECTIONS AND DETAILS FOR EXISTING FOOTPATH, KERB, TABLETOP CROSSING, BOLLARDS |
| | | | | | Client Name : | | | | Creative Footprints 40/120, Ground Floor, Chittaranjan Park, New Delhi - 110019 Tel. : +91 7042758806 Email : bigfoot@creativefootprints.co.in Website : www.creativefootprints.co.in | Drawn By: MD SADAF HUSSAIN |
| | | | | | ICLEI-Local Governments for Sustainability South Asia | | | | | Date: 05-03-2023 |
| | | | | | | | | | | Scale: 1:50 @ A3 |
| | | | | | | | | | | Checked By: ADARSHA KAPOOR |
| | | | | | | | | | | Revision: |
| | | | | | | | | | | Drawing No.: UD-CFCII-22-SEC-01 |

RFP for Development of three Child and Family-friendly junctions and 1.5km Connected shared Street at Saheli Marg and Big Bazar Rd, Udaipur, Rajasthan

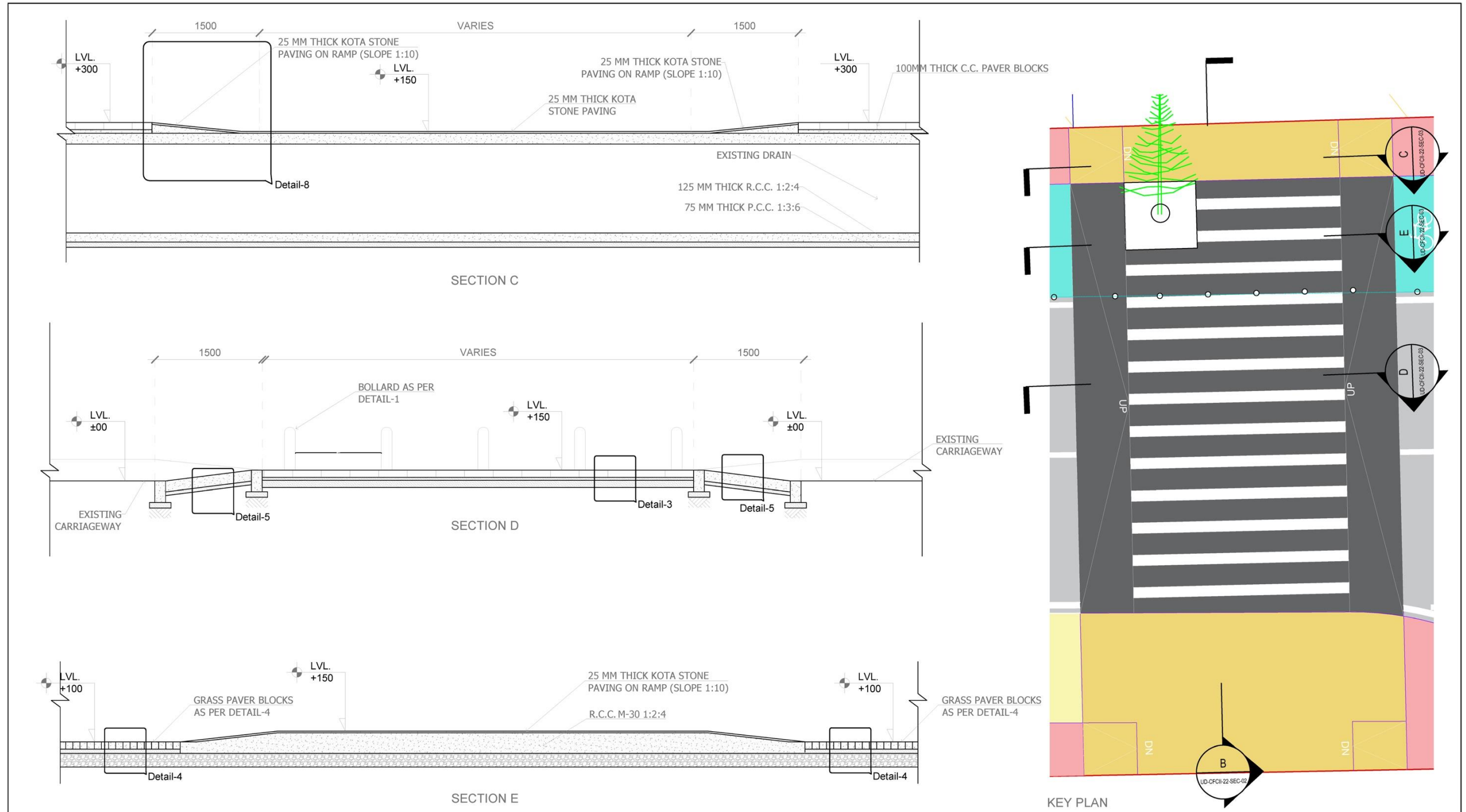

| Revision No | Dated | Description | Notes: | Description | Project Name : | Supported By | City Partner | Technical Partner | Drawings Made by: | Drawing Title: |
|-------------|-------|-------------|--|-------------|---|--------------|--------------|-------------------|---|--|
| | | | 1. ALL DIMENSIONS ARE IN M 2. Any discrepancy noted at any stage and in any form is to be immediately brought to the notice of the architect. | | UDAIPUR- AN URBAN95 CITY PHASE II | | | | Creative Footprints 40/120, Ground Floor, Chittaranjan Park, New Delhi - 110019 Tel. : +91 7042758806 Email : bigfoot@creativefootprints.co.in Website : www.creativefootprints.co.in | TYPICAL SECTIONS FOR EXISTING FOOTPATH AND TABLETOP CROSSING |
| | | | | | Client Name : | | | | | Drawn By: MD SADAF HUSSAIN |
| | | | | | ICLEI-Local Governments for Sustainability South Asia | | | | | Checked By: ADARSHA KAPOOR |
| | | | | | | | | | | Date: 05-03-2023 |
| | | | | | | | | | | Scale: 1:50 @ A3 |
| | | | | | | | | | | Revision: |
| | | | | | | | | | | Drawing No.: UD-CFCII-22-SEC-03 |

RFP for Development of three Child and Family-friendly junctions and 1.5km Connected shared Street at Saheli Marg and Big Bazar Rd, Udaipur, Rajasthan

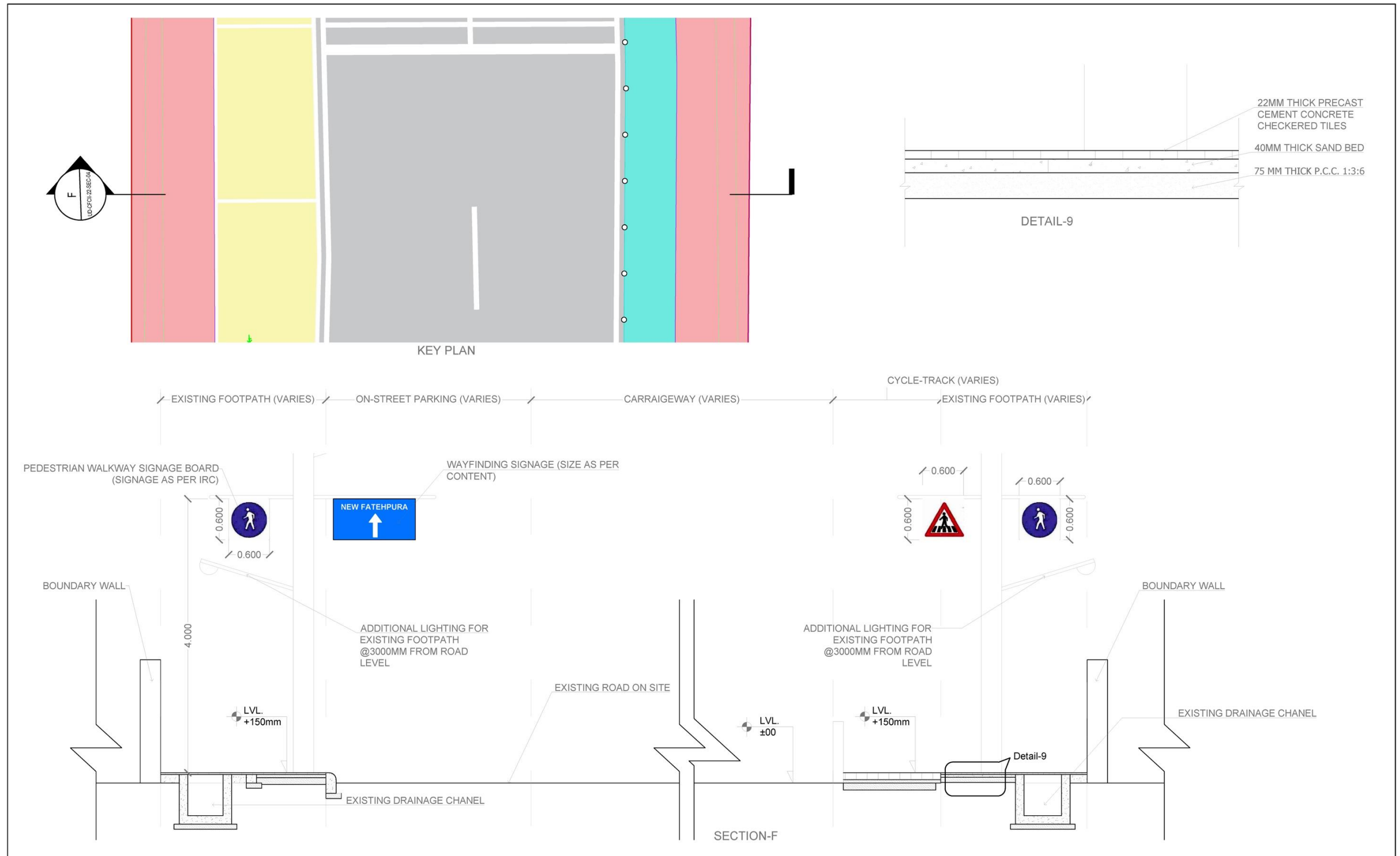

| Revision No | Dated | Description | Notes: | Description | Project Name : | Supported By | City Partner | Technical Partner | Drawings Made by: | Drawing Title: |
|-------------|-------|-------------|--|-------------|---|--------------|--------------|-------------------|--|---|
| | | | 1. ALL DIMENSIONS ARE IN M 2. Any discrepancy noted at any stage and in any form is to be immediately brought to the notice of the architect. | | UDAIPUR- AN URBAN95 CITY PHASE II | | | | Creative Footprints 40/120, Ground Floor, Chittaranjan Park, New Delhi - 110019 Tel. : +91 7042758806 Email : bigfoot@creativefootprints.co.in Website : www.creativefootprints.co.in | TYPICAL SECTIONS AND DETAILS FOR EXISTING FOOTPATH, KERB, TABLETOP CROSSING, BOLLARDS |
| | | | | | Client Name : | | | | | Drawn By: MD SADAF HUSSAIN |
| | | | | | ICLEI-Local Governments for Sustainability South Asia | | | | | Date: 04-06-2023 |
| | | | | | | | | | | Scale: 1:50 @ A3 |
| | | | | | | | | | | Checked By: ADARSHA KAPOOR |
| | | | | | | | | | | Revision: |
| | | | | | | | | | | Drawing No.: UD-CFCII-22-SEC-04 |

RFP for Development of three Child and Family-friendly junctions and 1.5km Connected shared Street at Saheli Marg and Big Bazar Rd, Udaipur, Rajasthan

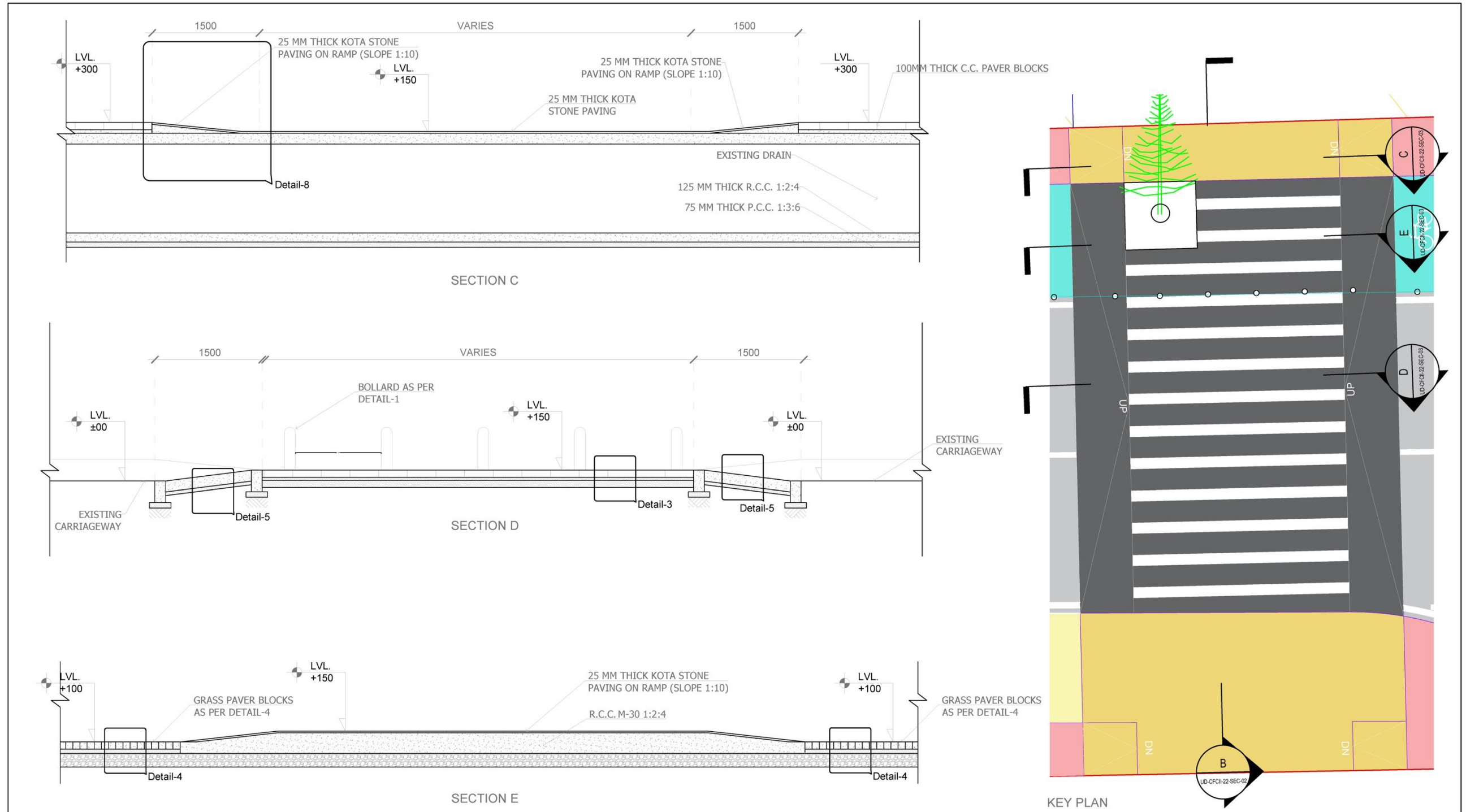

| Revision No | Dated | Description | Notes: | Description | Project Name : | Supported By | City Partner | Technical Partner | Drawings Made by: | Drawing Title: |
|-------------|-------|-------------|--|-------------|---|--------------|--------------|-------------------|---|--|
| | | | 1. ALL DIMENSIONS ARE IN M 2. Any discrepancy noted at any stage and in any form is to be immediately brought to the notice of the architect. | | UDAIPUR- AN URBAN95 CITY PHASE II | | | | Creative Footprints 40/120, Ground Floor, Chittaranjan Park, New Delhi - 110019 Tel. : +91 7042758806 Email : bigfoot@creativefootprints.co.in Website : www.creativefootprints.co.in | TYPICAL SECTIONS FOR EXISTING FOOTPATH AND TABLETOP CROSSING |
| | | | | | Client Name : | | | | | Drawn By: MD SADAF HUSSAIN |
| | | | | | ICLEI-Local Governments for Sustainability South Asia | | | | | Checked By: ADARSHA KAPOOR |
| | | | | | | | | | | Date: 05-03-2023 |
| | | | | | | | | | | Scale: 1:50 @ A3 |
| | | | | | | | | | | Revision: |
| | | | | | | | | | | Drawing No.: UD-CFCII-22-SEC-03 |

RFP for Development of three Child and Family-friendly junctions and 1.5km Connected shared Street at Saheli Marg and Big Bazar Rd, Udaipur, Rajasthan

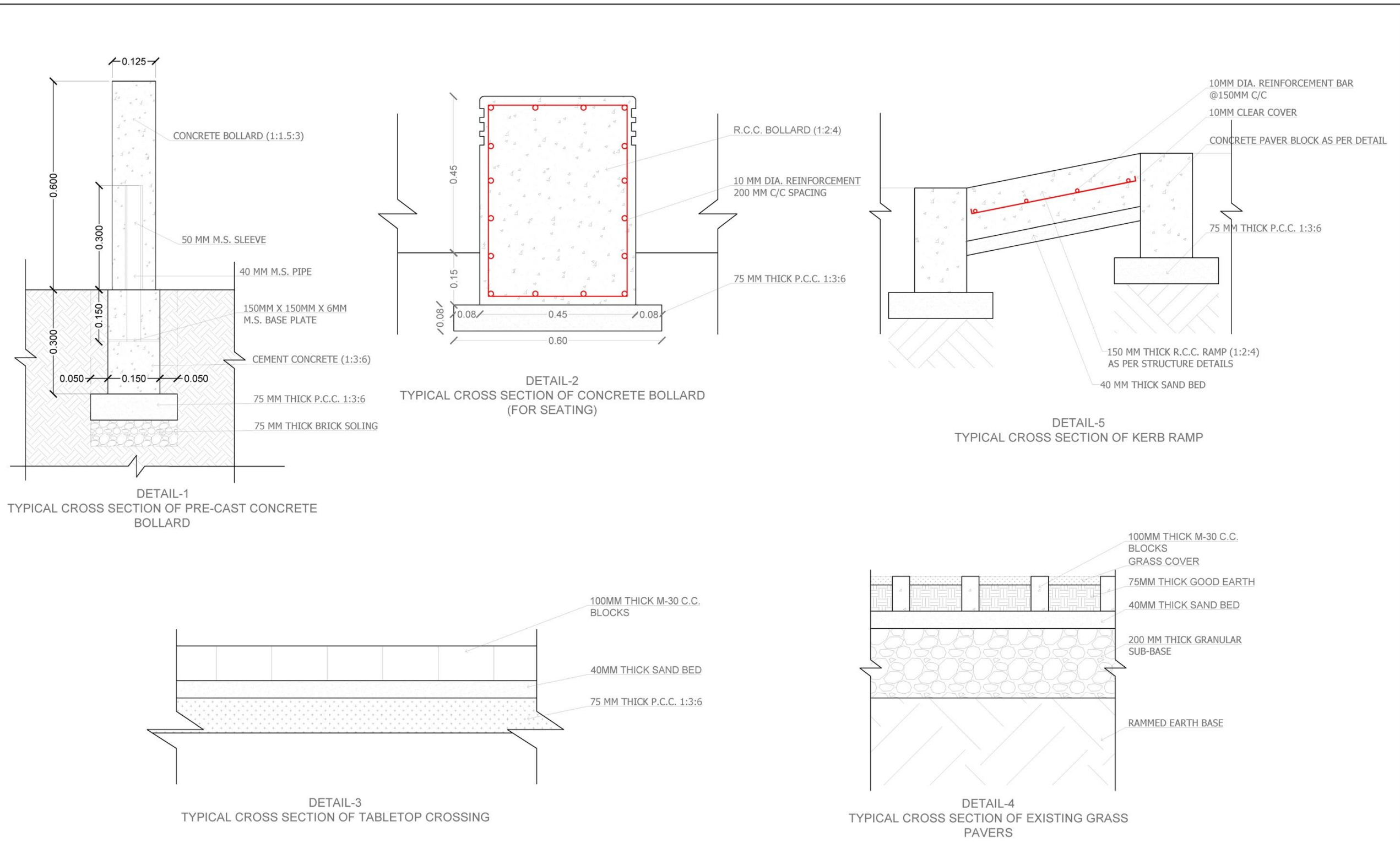

| Revision No | Dated | Description | Notes: Description | Project Name : | Supported By | City Partner | Technical Partner | Design Made by: | Drawing Title: | | | | | | | |
|-------------------------------|------------------|------------------------------------|--|--|--------------|--------------|-------------------|--|---|-------------------------------|------------------|------------------------------------|-------------------------------|------------------|--|--------------|
| 1 | 1-6-2023 | DETAIL-1 REVISED | 1. ALL DIMENSIONS ARE IN M 2. Any discrepancy noted at any stage and in any form is to be immediately brought to the notice of the architect. | UDAIPUR- AN URBAN95 CITY PHASE II | | | | Creative Footprints 40/120, Ground Floor, Chittaranjan Park, New Delhi - 110019 Tel. : +91 7042758806 Email : bigfoot@creativefootprints.co.in Website : www.creativefootprints.co.in | TYPICAL CROSS-SECTIONAL DETAILS FOR BOLLARDS, EXISTING GRASS PAVERS AND TABLETOP CROSSING | | | | | | | |
| | | | | Client Name : ICLEI-Local Governments for Sustainability South Asia | | | | | <table border="1"> <tr> <td>Drawn By: MD SADAF HUSSAIN</td> <td>Date: 01-06-2023</td> <td rowspan="3">Drawing No.: UD-CFCII-22-DET-01</td> </tr> <tr> <td>Checked By: ADARSHA KAPOOR</td> <td>Scale: 1:10 @ A3</td> </tr> <tr> <td></td> <td>Revision: R1</td> </tr> </table> | Drawn By: MD SADAF HUSSAIN | Date: 01-06-2023 | Drawing No.: UD-CFCII-22-DET-01 | Checked By: ADARSHA KAPOOR | Scale: 1:10 @ A3 | | Revision: R1 |
| Drawn By: MD SADAF HUSSAIN | Date: 01-06-2023 | Drawing No.: UD-CFCII-22-DET-01 | | | | | | | | | | | | | | |
| Checked By: ADARSHA KAPOOR | Scale: 1:10 @ A3 | | | | | | | | | | | | | | | |
| | Revision: R1 | | | | | | | | | | | | | | | |

RFP for Development of three Child and Family-friendly junctions and 1.5km Connected shared Street at Saheli Marg and Big Bazar Rd, Udaipur, Rajasthan

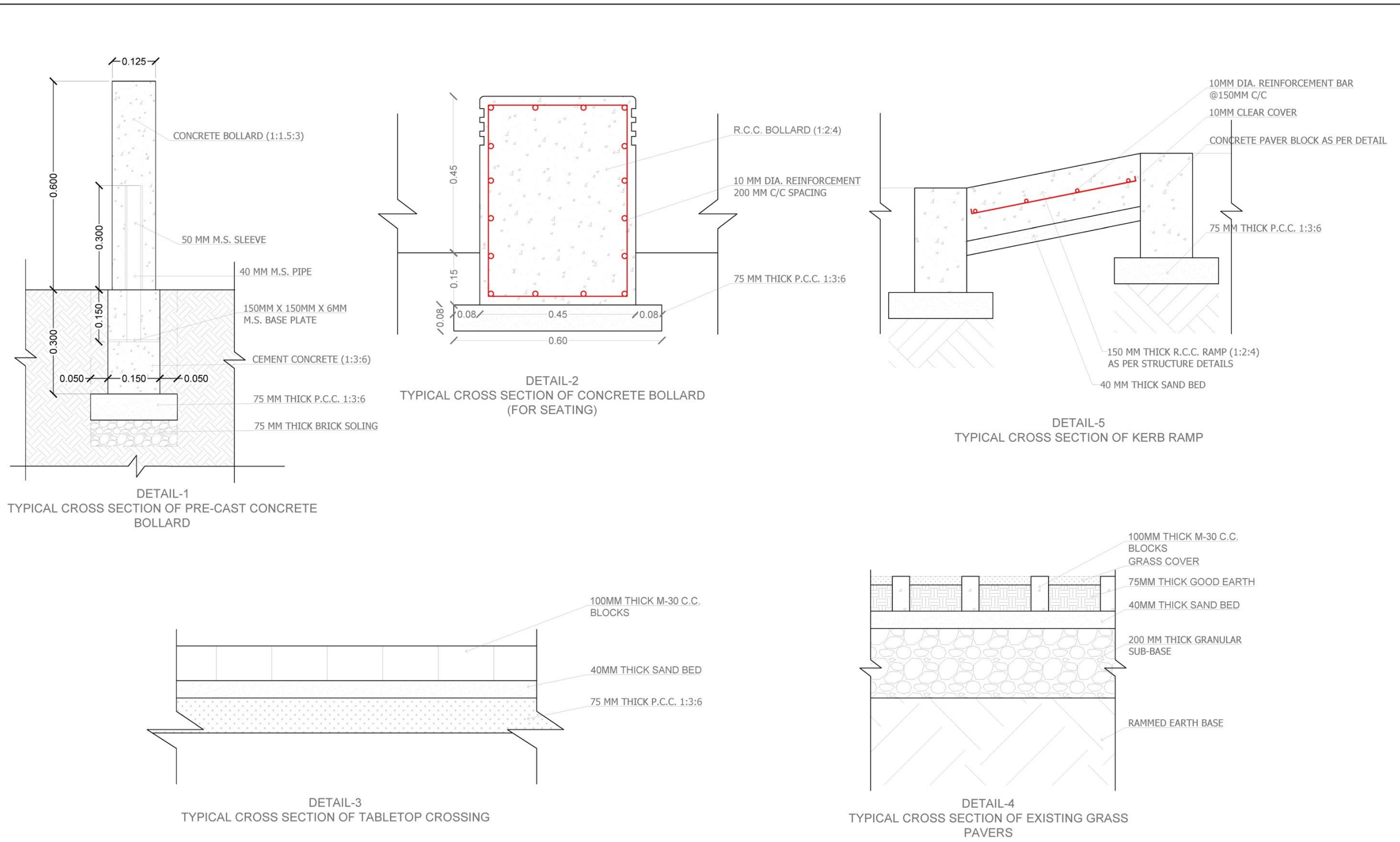

| Revision No | Dated | Description | Notes: Description | Project Name : | Supported By | City Partner | Technical Partner | Design Made by: | Drawing Title: |
|-------------|----------|------------------|--|---|--------------|--------------|-------------------|--|---|
| 1 | 1-6-2023 | DETAIL-1 REVISED | 1. ALL DIMENSIONS ARE IN M 2. Any discrepancy noted at any stage and in any form is to be immediately brought to the notice of the architect. | UDAIPUR- AN URBAN95 CITY PHASE II | | | | Creative Footprints 40/120, Ground Floor, Chittaranjan Park, New Delhi - 110019 Tel. : +91 7042758806 Email : bigfoot@creativefootprints.co.in Website : www.creativefootprints.co.in | TYPICAL CROSS-SECTIONAL DETAILS FOR BOLLARDS, EXISTING GRASS PAVERS AND TABLETOP CROSSING Drawn By: MD SADAF HUSSAIN Checked By: ADARSHA KAPOOR Date: 01-06-2023 Scale: 1:10 @ A3 Revision: R1 |
| | | | | Client Name : ICLEI-Local Governments for Sustainability South Asia | | | | | Drawing No.: UD-CFCII-22-DET-01 |

RFP for Development of three Child and Family-friendly junctions and 1.5km Connected shared Street at Saheli Marg and Big Bazar Rd, Udaipur, Rajasthan

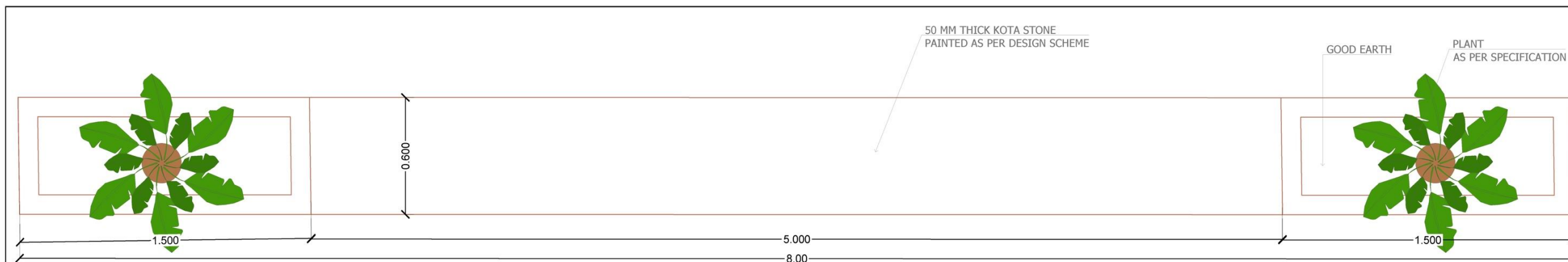

PLAN-SEATING WITH PLANTER

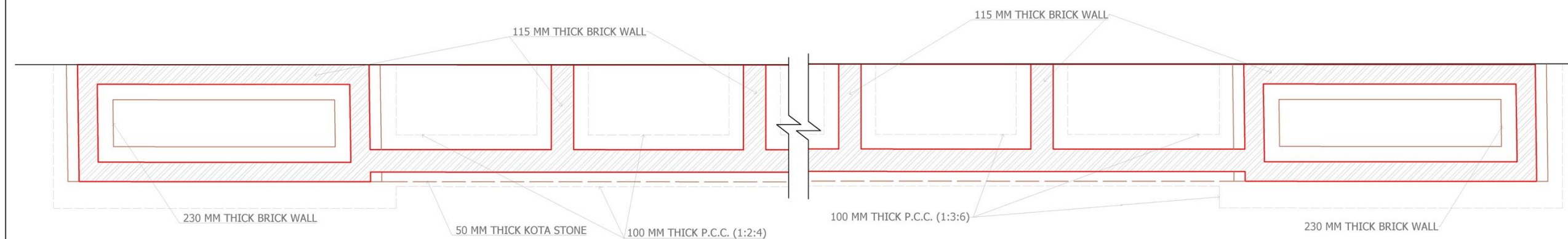

PLAN-SEATING WITH PLANTER (@350mm LVL. FROM G.L.)

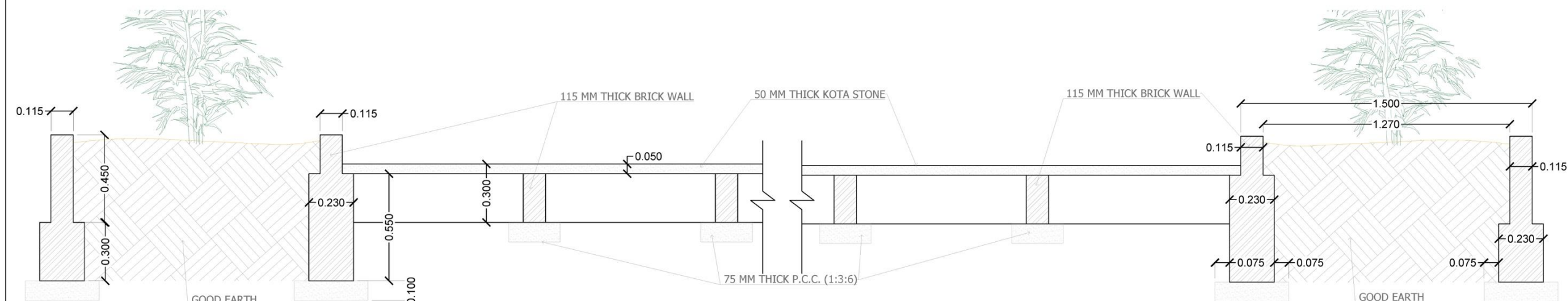

TYPICAL CROSS SECTION-SEATING WITH PLANTER

| Revision No | Dated | Description | Notes: | Description | Project Name : | Supported By | City Partner | Technical Partner | Design Made by: | Drawing Title: |
|-------------|----------|--|--|-------------|---|--------------|--------------|-------------------|---|--|
| 1 | 1-6-2023 | R.C.C. USED IN SEATING AND PLANTER REPLACED BY BRICKWORK | 1. ALL DIMENSIONS ARE IN M 2. Any discrepancy noted at any stage and in any form is to be immediately brought to the notice of the architect. | | UDAIPUR- AN URBAN95 CITY PHASE II | | | | Creative Footprints 40/120, Ground Floor, Chittaranjan Park, New Delhi - 110019 Tel. : +91 7042758806 Email : bigfoot@creativefootprints.co.in Website : www.creativefootprints.co.in | TYPICAL CROSS-SECTIONAL DETAILS FOR SEATING WITH PLANTER |
| | | | | | Client Name : | | | | | Drawn By: MD SADAF HUSSAIN |
| | | | | | ICLEI-Local Governments for Sustainability South Asia | | | | | Checked By: ADARSHA KAPOOR |
| | | | | | | | | | | Date: 05-03-2023 |
| | | | | | | | | | | Scale: 1:20 @ A3 |
| | | | | | | | | | | Revision: R1 |
| | | | | | | | | | | Drawing No.: UD-CFCII-22-DET-04 |

RFP for Development of three Child and Family-friendly junctions and 1.5km Connected shared Street at Saheli Marg and Big Bazar Rd, Udaipur, Rajasthan

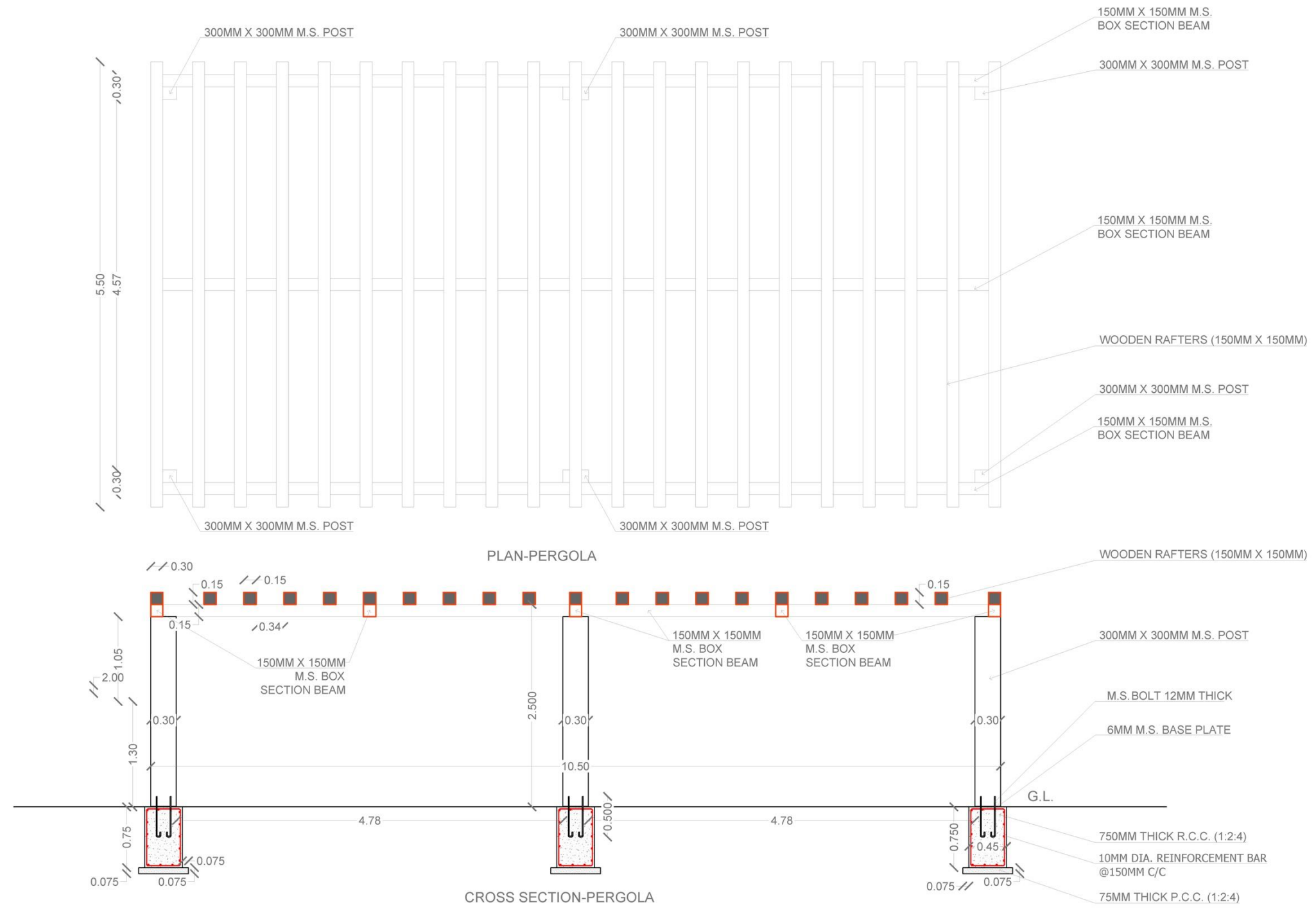

| Revision No | Dated | Description | Notes: | Description | Project Name : | Supported By | City Partner | Technical Partner | Design Made by: | Drawing Title: |
|-------------|-------|-------------|--|-------------|---|--------------|--------------|-------------------|--|---|
| | | | 1. ALL DIMENSIONS ARE IN M 2. Any discrepancy noted at any stage and in any form is to be immediately brought to the notice of the architect. | | UDAIPUR- AN URBAN95 CITY PHASE II | | | | Creative Footprints 40/120, Ground Floor, Chittaranjan Park, New Delhi - 110019 Tel. : +91 7042758806 Email : bigfoot@creativefootprints.co.in Website : www.creativefootprints.co.in | TYPICAL CROSS-SECTIONAL DETAILS FOR PERGOLA |
| | | | | | Client Name : | | | | | Drawn By: |
| | | | | | ICLEI-Local Governments for Sustainability South Asia | | | | | MD SADAF HUSSAIN |
| | | | | | | | | | | Date: 05-06-2023 |
| | | | | | | | | | | Scale: 1:50 @ A3 |
| | | | | | | | | | | Checked By: |
| | | | | | | | | | | ADARSHA KAPOOR |
| | | | | | | | | | | Revision: R1 |
| | | | | | | | | | | Drawing No.: |
| | | | | | | | | | | UD-CFCII-22-DET-05 |

RFP for Development of three Child and Family-friendly junctions and 1.5km Connected shared Street at Saheli Marg and Big Bazar Rd, Udaipur, Rajasthan

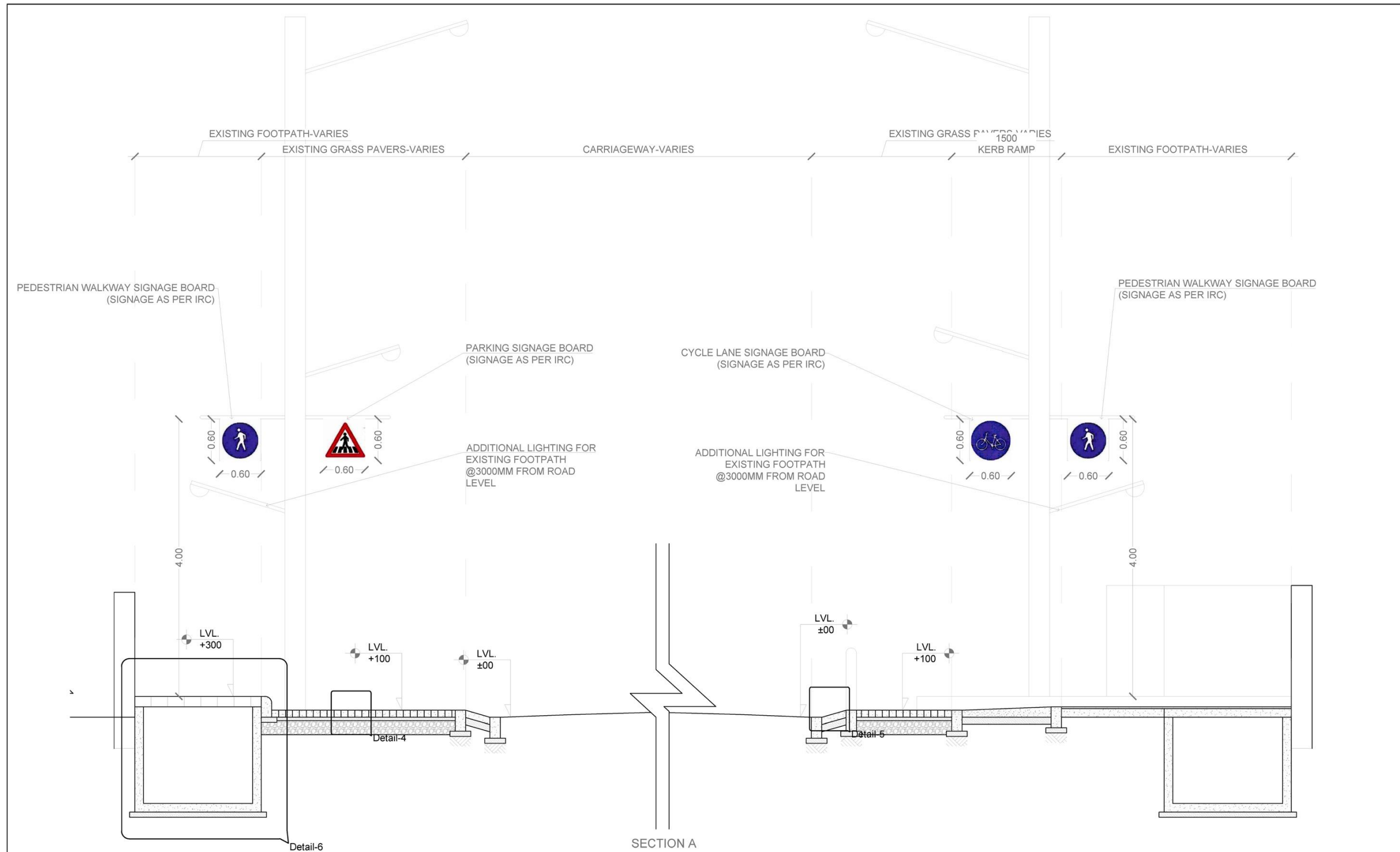

| Revision No | Dated | Description | Notes: | Description | Project Name : | Supported By | City Partner | Technical Partner | Design Made by: | Drawing Title: |
|-------------|-------|-------------|--|-------------|---|--------------|--------------|-------------------|--|---|
| | | | 1. ALL DIMENSIONS ARE IN M 2. Any discrepancy noted at any stage and in any form is to be immediately brought to the notice of the architect. | | UDAIPUR- AN URBAN95 CITY PHASE II | | | | Creative Footprints 40/120, Ground Floor, Chittaranjan Park, New Delhi - 110019 Tel. : +91 7042758806 Email : bigfoot@creativefootprints.co.in Website : www.creativefootprints.co.in | TYPICAL SECTIONS AND DETAILS FOR EXISTING FOOTPATH, KERB, TABLETOP CROSSING, BOLLARDS |
| | | | | | Client Name : | | | | | Drawn By: MD SADAF HUSSAIN |
| | | | | | ICLEI-Local Governments for Sustainability South Asia | | | | | Date: 05-03-2023 |
| | | | | | | | | | | Scale: 1:50 @ A3 |
| | | | | | | | | | | Checked By: ADARSHA KAPOOR |
| | | | | | | | | | | Revision: |
| | | | | | | | | | | Drawing No.: UD-CFCII-22-SEC-01 |

RFP for Development of three Child and Family-friendly junctions and 1.5km Connected shared Street at Saheli Marg and Big Bazar Rd, Udaipur, Rajasthan

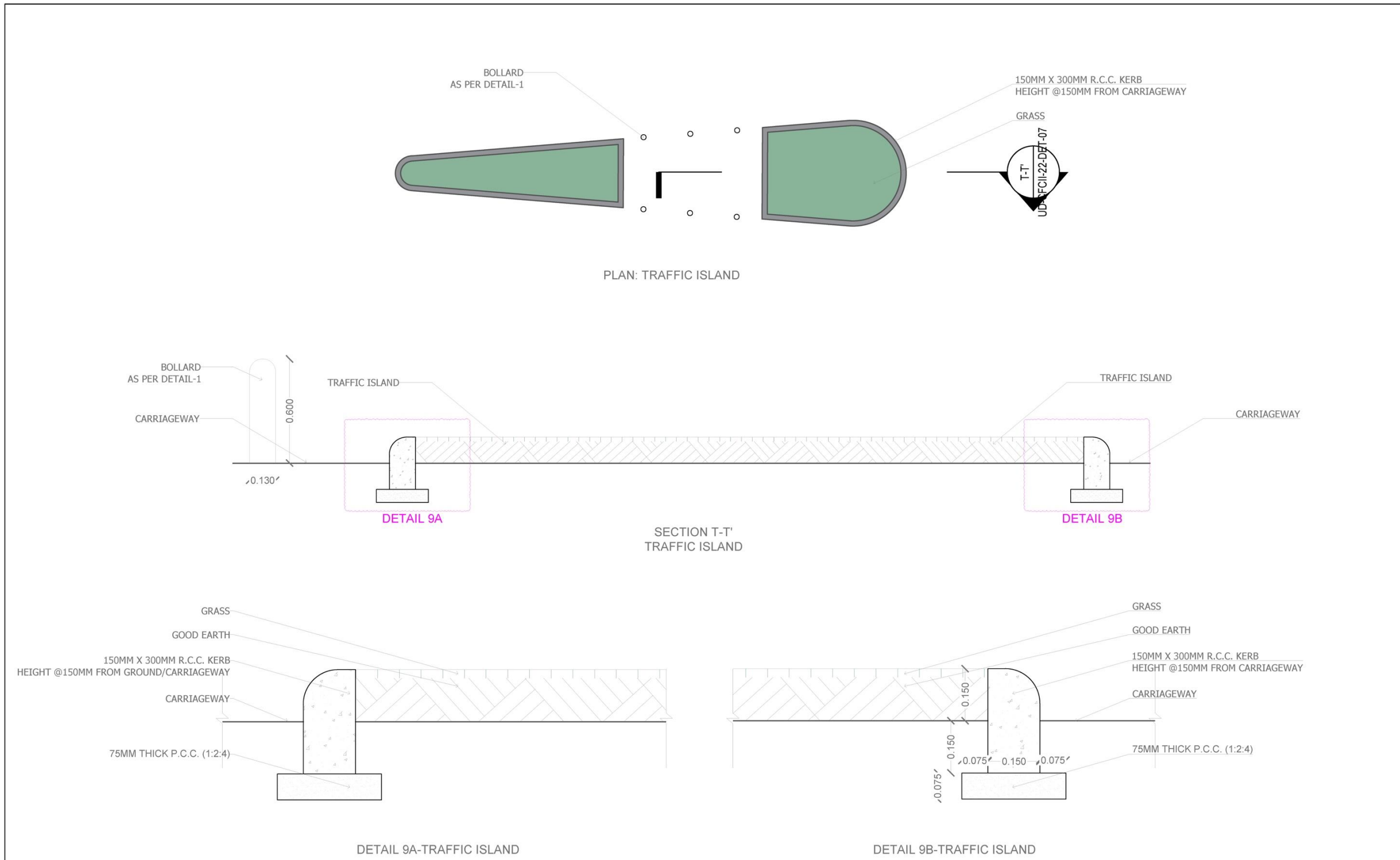

| Revision No | Dated | Description | Notes: | Description | Project Name : | Supported By | City Partner | Technical Partner | Design Made by: | Drawing Title: |
|-------------|-------|-------------|--|---|-----------------------------------|--------------|--------------|-------------------|--|------------------------------------|
| | | | 1. ALL DIMENSIONS ARE IN M 2. Any discrepancy noted at any stage and in any form is to be immediately brought to the notice of the architect. | UDAIPUR- AN URBAN95 CITY PHASE II | UDAIPUR- AN URBAN95 CITY PHASE II | | | | | TYPICAL DETAILS FOR TRAFFIC ISLAND |
| | | | | Client Name : | | | | | Creative Footprints 40/120, Ground Floor, Chittaranjan Park, New Delhi - 110019 Tel. : +91 7042758806 Email : bigfoot@creativefootprints.co.in Website : www.creativefootprints.co.in | Drawn By: MD SADAF HUSSAIN |
| | | | | ICLEI-Local Governments for Sustainability South Asia | | | | | | Date: 18-05-2023 |
| | | | | | | | | | | Scale: 1:10@ A3 |
| | | | | | | | | | | Checked By: ADARSHA KAPOOR |
| | | | | | | | | | | Revision: |
| | | | | | | | | | | Drawing No.: UD-CFCII-22-DET-07 |

RFP for Development of three Child and Family-friendly junctions and 1.5km Connected shared Street at Saheli Marg and Big Bazar Rd, Udaipur, Rajasthan

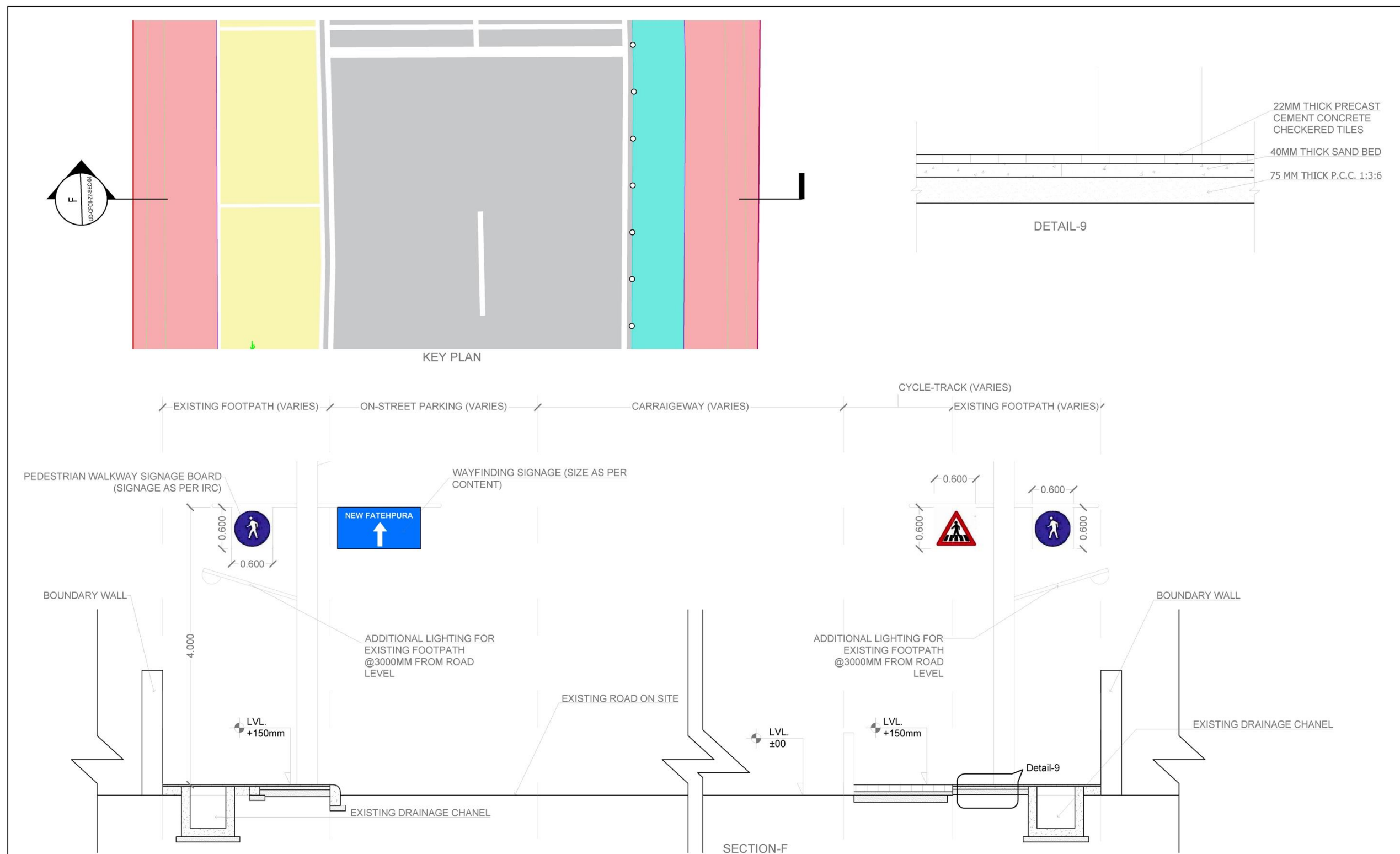

| Revision No | Dated | Description | Notes: | Description | Project Name : | Supported By | City Partner | Technical Partner | Drawings Made by: | Drawing Title: |
|-------------|-------|-------------|--|-------------|---|--------------|--------------|-------------------|--|---|
| | | | 1. ALL DIMENSIONS ARE IN M 2. Any discrepancy noted at any stage and in any form is to be immediately brought to the notice of the architect. | | UDAIPUR- AN URBAN95 CITY PHASE II | | | | Creative Footprints 40/120, Ground Floor, Chittaranjan Park, New Delhi - 110019 Tel. : +91 7042758806 Email : bigfoot@creativefootprints.co.in Website : www.creativefootprints.co.in | TYPICAL SECTIONS AND DETAILS FOR EXISTING FOOTPATH, KERB, TABLETOP CROSSING, BOLLARDS |
| | | | | | Client Name : | | | | | Drawn By: MD SADAF HUSSAIN |
| | | | | | ICLEI-Local Governments for Sustainability South Asia | | | | | Date: 04-06-2023 |
| | | | | | | | | | | Scale: 1:50 @ A3 |
| | | | | | | | | | | Checked By: ADARSHA KAPOOR |
| | | | | | | | | | | Revision: |
| | | | | | | | | | | Drawing No.: UD-CFCII-22-SEC-04 |

RFP for Development of three Child and Family-friendly junctions and 1.5km Connected shared Street at Saheli Marg and Big Bazar Rd, Udaipur, Rajasthan

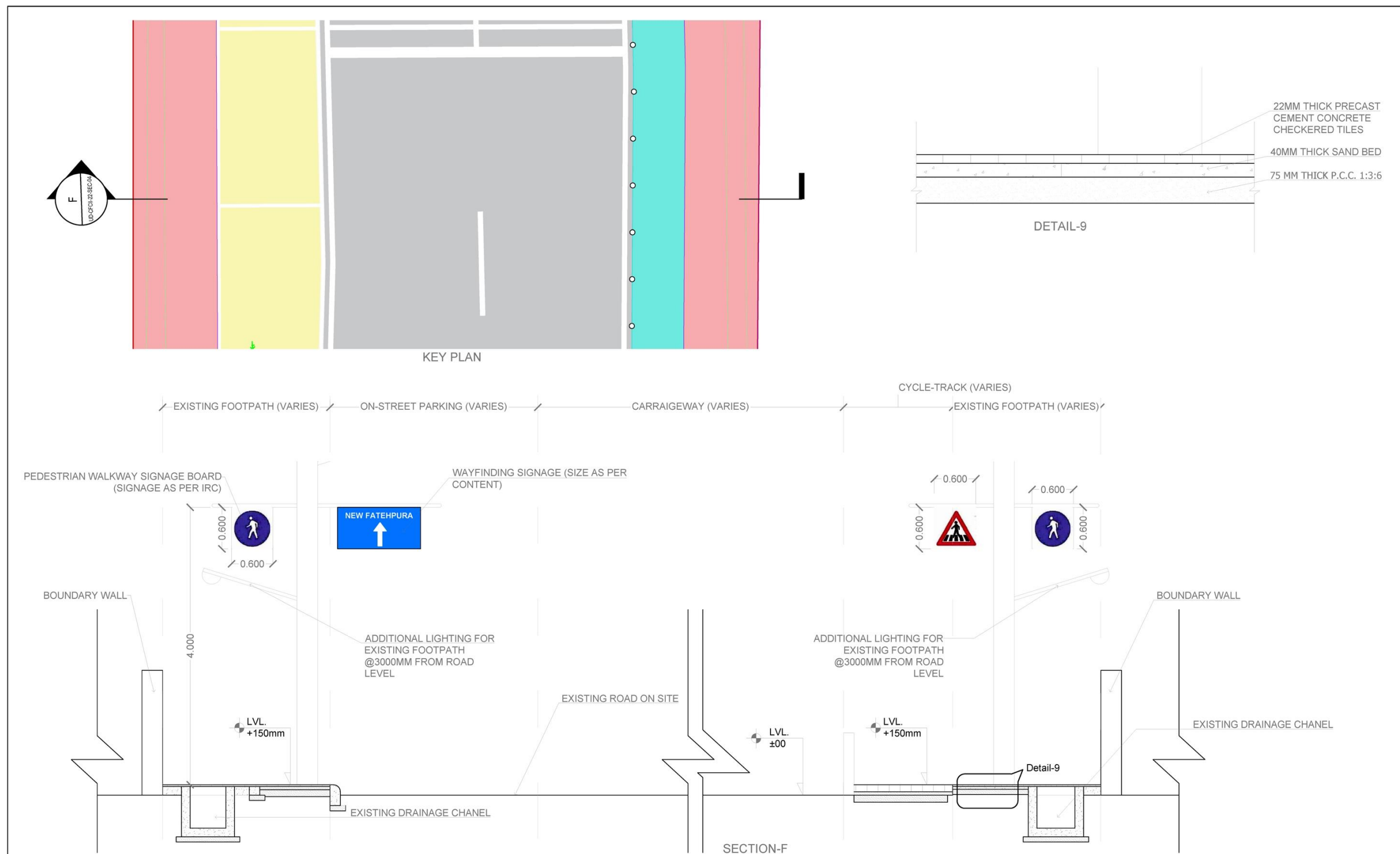

| Revision No | Dated | Description | Notes: | Description | Project Name : | Supported By | City Partner | Technical Partner | Drawings Made by: | Drawing Title: |
|-------------|-------|-------------|--|-------------|---|--------------|--------------|-------------------|--|---|
| | | | 1. ALL DIMENSIONS ARE IN M 2. Any discrepancy noted at any stage and in any form is to be immediately brought to the notice of the architect. | | UDAIPUR- AN URBAN95 CITY PHASE II | | | | Creative Footprints 40/120, Ground Floor, Chittaranjan Park, New Delhi - 110019 Tel. : +91 7042758806 Email : bigfoot@creativefootprints.co.in Website : www.creativefootprints.co.in | TYPICAL SECTIONS AND DETAILS FOR EXISTING FOOTPATH, KERB, TABLETOP CROSSING, BOLLARDS |
| | | | | | Client Name : | | | | | Drawn By: MD SADAF HUSSAIN |
| | | | | | ICLEI-Local Governments for Sustainability South Asia | | | | | Checked By: ADARSHA KAPOOR |
| | | | | | | | | | | Date: 04-06-2023 |
| | | | | | | | | | | Scale: 1:50 @ A3 |
| | | | | | | | | | | Revision: |
| | | | | | | | | | | Drawing No.: UD-CFCII-22-SEC-04 |

RFP for Development of three Child and Family-friendly junctions and 1.5km Connected shared Street at Saheli Marg and Big Bazar Rd, Udaipur, Rajasthan

11.2 ABSTRACT OF THE COST

| Development of three Child and Family-friendly junctions and 1.5km Connected shared Street at Saheli Marg (Total Including O&M) | | |
|--|---|---------------|
| S/n | PARTICULAR FOR SAHELI MARG | Amount |
| 1 | Part A – Saheli Marg | |
| | Part B – Big Bazaar Road | |
| | Subtotal (Part A+ Part B) | |
| 2 | Part C - O&M for 5 years (@10% of subtotal) | |
| 3 | Grand Total (Part A +Part B +Part C) | |
| | | |

RFP for Development of three Child and Family-friendly junctions and 1.5km Connected shared Street at Saheli Marg and Big Bazar Rd, Udaipur, Rajasthan

11.3 BILL OF QUANTITIES

| Development of Family-friendly junctions and Connected shared Street at Saheli Marg, Udaipur, Rajasthan (Saheli Marg- CIVIL- PART-A) | | | | |
|---|-----------------------|--|-------------|------------|
| S. No. | RUIDP SOR-2022 | ITEM DESCRIPTION | UNIT | QTY |
| SM-01 | 24.1 | Brick work with FPS bricks of class designation 75 in foundation and plinth in: | | |
| | 24.1.1 | Cement mortar 1:4 (1 cement : 4 coarse sand) Full Brick work in footing of seating with planter | cum | 23.48 |
| SM-02 | 24.7 | Brick work 7 cm thick with FPS brick of class designation 75 incement mortar 1:3 (1 cement : 3 coarse sand) in superstructure Half brick work in seating with planter | sqm | 250.78 |
| | 32.2 | Cement plastering including T&P, scaffolding, material and complete labour, including cost of water, curing, racking of joints etc. with 15 mm cement plaster on the rough side of single or half brick wall of mix : | | |
| SM-03 | 32.2.1 | 1:4 (1 cement : 4 fine/ coarse sand) Plaster on seating with planter | sqm | 250.78 |
| | 9.10 | Providing and fixing of precast concrete interlocking tiles of desired shape of M 30 grade manufactured from fully computerized automatic stationery hydraulic viebro pressed machine and fully computerized automatic batching plant of class A1/A2 as per BS 6717:2001. The CC interlocking paving blocks be laid on average 50mm. thick bed of coarse sand and the joint is to be filled with fine sand. Laying procedure on compacted sub-base as defined. Complete job is to be executed as per the instruction of Engineer incharge. The rates to be inclusive of all lead & Lifts etc. complete as per specifications. Tensile splitting strength, abrasion and braking load etc. as per BS 6717:2001, Grey cement. | | |
| SM-04 | 9.10.3 | 100mm thick In Table tops | sqm | 3028.66 |
| | 10.8 | Providing and laying marking of center line and stop line etc with hot thermoplastic compound 2.5 mm thick on road/ plain surface, including reflectorising glass beads @ 250 gms per sqm area with special applicator machine, as per IRC:35 including cleaning the surface of all dirt, dust and other foreign matter, demarcation at site and traffic control involved. The finished surface to be level, uniform and free from streaks and holes as per clause 803 of MoRT&H Specification including all material, labour, machinery, lighting, | sqm | 1447.48 |

RFP for Development of three Child and Family-friendly junctions and 1.5km Connected shared Street at Saheli Marg and Big Bazar Rd, Udaipur, Rajasthan

| Development of Family-friendly junctions and Connected shared Street at Saheli Marg, Udaipur, Rajasthan (Saheli Marg- CIVIL- PART-A) | | | | |
|---|---------------------------------------|---|------|---------|
| S. No. | RUIDP SOR-2022 | ITEM DESCRIPTION | UNIT | QTY |
| | | guarding and maintenance of diversion. | | |
| SM-06 | 10.9 | Providing and fixing of retro- reflectorised cautionary, mandatory and informatory sign as per IRC :67 made of encapsulated lens type reflective sheeting vide clause 801.3, fixed over aluminium sheeting, 1.5 mm thick supported on a mild steel angle iron post 3 metre long and size 75 mm x 75 mm x 6 mm firmly fixed to the ground by means of properly designed foundation with M15 grade cement concrete 45 cm x 45 cm x 60 cm, 60 cm below ground level as per approved drawing including all material, labour. | | |
| | 10.9.2 | 60 cm equilateral triangle | each | 74.00 |
| | 10.9.3 | 60 cm circular | each | 11.00 |
| | | Both the above are traffic signage | | |
| SM-09 | 10.10 | Providing and erecting direction and place identification retroreflectorised sign as per IRC:67 made of encapsulated lens type reflective sheeting vide clause 801.3, fixed over aluminium sheeting, 2 mm thick framed to angle iron 40x40x5mm with area not exceeding 0.9 sqm supported on a mild steel single angle iron post 75 x 75 x 6 mm firmly fixed to the ground by means of properly designed foundation with M15 grade cement concrete 45 x 45 x 60 cm, 60 cm below ground level as per approved drawing including all material, labour. | sqm | 11.00 |
| | | For rectangular wayfinding signage (size as per content) | | |
| SM-11 | 4.2 | Earth work in excavation for roadway, including trimming bottom and side slopes in accordance with requirement of line, grades and cross sections, including disposal of surplus material with all lift and lead upto 1000 metre as per MoRT&H specification clause 301. | | |
| | 4.2.1 | In all type of soil | | |
| | | Excavation for table tops | cum | 454.30 |
| | | Excavation for zebra crossing ramps | cum | 2.38 |
| | Excavation for table top ramps | cum | 2.84 | |
| SM-12 | 32.35 | Finishing walls with Acrylic Smooth exterior paint of required shade : | | |
| | 32.35.1 | New work (Two or more coat applied @ 1.67 ltr/10 sqm over and including base coat of water proofing cement paint applied @ 2.20 kg/ 10 sqm). Floor Art | sqm | 1382.14 |

RFP for Development of three Child and Family-friendly junctions and 1.5km Connected shared Street at Saheli Marg and Big Bazar Rd, Udaipur, Rajasthan

| Development of Family-friendly junctions and Connected shared Street at Saheli Marg, Udaipur, Rajasthan (Saheli Marg- CIVIL- PART-A) | | | | |
|---|-----------------------|--|---|------------|
| S. No. | RUIDP SOR-2022 | ITEM DESCRIPTION | UNIT | QTY |
| | | Wall Art | sqm | 63.48 |
| | | Walls of seating with planter | sqm | 250.78 |
| SM-13 | 12.7 | Providing and fixing stone slab covering of required size over drains including filling of joints with cement sand mortar 1:3 complete as per direction of Engineer-in-charge. | | |
| | 12.7.2 | Average thickness 40 to 50 mm | | |
| | | Benches (Kota Stone) rectangular Units | sqm | 110.40 |
| | | Benches (Kota Stone) curved | sqm | 23.70 |
| | | For kota stone finish on seating with planter | | |
| SM-14 | 28.155 | Supply and Installation of SMALL ROOM (TOILET & GUARD ROOM) with following thickness PREFABRICATED INSULATED PPGL FACE closed lip panels (for door, wall and roof) of thickness mentioned below. Panel shall have 0.50mm (+/-0.04mm) thick precoated metal sheet on both sides of rigid PUR insulation. The precoated metal sheet shall be PPGL (Pre Painted Galvalume Sheet with AZ coating) sheet having SDP (Super Durable Polyester) colour coat of 18 micron(min). The Pre coated metal sheet on both sides must be pre-strengthened by full lengthwise stiffening with semicircular beading of 12mm wide & 3mm depth at 240 (+/-5) mm pitch. Panels shall have closed lengthwise sides made by right angle flange on both side of Pre coated metal sheets, free from cap type covers. The top and bottom part on width wise sides of panels must have full width MS Square tube insert of (min 25mm x 1.0mm) for better screw retention and strength. The insulation core shall be selfextinguishing DIN 4102,Class B3 fire retardant class rigid PUR with thermal conductivity of 0.025 W/mK and with density of 40kg/m ³ (+/- 2kg) suitable for temperature range of -30 degree C to +80 degree C. The panel must be made using glue-free high pressure hot pressing self-bonding method free from major undulations. PPGL sheet on both sides of panel shall have a min15 micron protective plastic guard film to avoid scratches during transportation. | | |
| | 28.155.2 | Thickness of 50mm (+/-2mm) | | |
| | | | For breast feeding booth infront of Saheliyon Ki Bari Entrance | sqm |
| SM-15 | DSR-2021-4.9 | Precasting and placing in position 125 mm dia Bollards 600 mm high of required shape including providing M.S. Pipe Sleeve 50 mm dia 300 mm long in the Bollard and M.S. Pipes 40 mm dia and 450mm long with 150x150x6mm M.S. plate welded at bottom and embedded | | |

RFP for Development of three Child and Family-friendly junctions and 1.5km Connected shared Street at Saheli Marg and Big Bazar Rd, Udaipur, Rajasthan

| Development of Family-friendly junctions and Connected shared Street at Saheli Marg, Udaipur, Rajasthan (Saheli Marg- CIVIL- PART-A) | | | | |
|---|-----------------------|---|-------------|------------|
| S. No. | RUIDP SOR-2022 | ITEM DESCRIPTION | UNIT | QTY |
| | | 150mm in cement concrete 1:3:6 (1 Cement : 3 coarse sand (zone-III) derived from natural sources : 6 graded stone aggregate 20 mm nominal size derived from natural sources), including necessary excavation of size 250x250x450mm deep for the same in bitumen/concrete pavement at specified spacing. | | |
| | | Precast bollards, including all items and cement in the foundation, but excluding cement in the section above ground | each | 1081.00 |
| SM-16 | 21.1 | Providing and laying in position cement concrete of specified grade excluding the cost of centring and shuttering - All work upto plinth level : | | |
| | 21.1.2 | 1:1½:3 (1 Cement : 1½ coarse sand : 3 graded stone aggregate 20 mm nominal size). Cement in the section above ground of precast concrete bollards | cum | 7.32 |
| SM-17 | 21.1 | Providing and laying in position cement concrete of specified grade excluding the cost of centring and shuttering - All work upto plinth level : | | |
| | 21.1.5 | 1:3:6 (1 Cement : 3 coarse sand : 6 graded stone aggregate 20 mm nominal size). P.C.C. in Seating Bollards (12 nos) | cum | 0.25 |
| | | P.C.C. In seating with planters | cum | 3.18 |
| SM-18 | 23.3 | Reinforced cement concrete work in beams, suspended floors, roofs having slope upto 15° landings, balconies, shelves, chajjas, lintels, bands, plain window sills, staircases and spiral stair cases upto two stories excluding the cost of centring, shuttering, finishing and reinforcement: | | |
| | 23.3.1 | M-15 Grade Concrete (1:2:4 (1 cement : 2 coarse sand : 4 graded stone aggregate 20 mm nominal size) -As per design mix) | | |
| | | R.C.C. In table tops | cum | 5.68 |
| | | R.C.C. In table tops ramps | cum | 4.76 |
| | | R.C.C. In footpath ramps | cum | 6.58 |
| | | R.C.C. In Seating Bollards | cum | 1.14 |
| SM-20 | 28.113 | Providing and fixing Bamboo jaffery/ fencing consisting of superior quality 25mm dia (Average) half cut bamboo placed vertically and fixed together with three numbers horizontal running members of hollock wood in scantling of section 50X25mm fixed with nails and G.I wire to existing surface complete as per direction of Engineer-in- charge. | | |

RFP for Development of three Child and Family-friendly junctions and 1.5km Connected shared Street at Saheli Marg and Big Bazar Rd, Udaipur, Rajasthan

| Development of Family-friendly junctions and Connected shared Street at Saheli Marg, Udaipur, Rajasthan (Saheli Marg- CIVIL- PART-A) | | | | |
|---|----------------|--|-------|---------|
| S. No. | RUIDP SOR-2022 | ITEM DESCRIPTION | UNIT | QTY |
| | | Bamboo Jafri for screening of transformers on the road(Refer dwg. UD-CFCII-22-DET-08) | sqm | 100.80 |
| SM-21 | 32.47 | Providing and applying two coats of fire retardant paint unthinned on cleaned wood/ply surface @ 3.5 sqm per litre per coat including preparation of base surface as per recommendations of manufacturer to make the surface fire retardant. | | |
| | | Fire retardant paint for bamboo jafri | sqm | 100.80 |
| SM-22 | 23.19 | Reinforcement for R.C.C. work at all levels including straightening, cutting, bending, placing in position and binding all complete. | | |
| | 23.19.6 | Thermo-Mechanically Treated bars. | | |
| | | Reinforcement bars in R.C.C. for Table tops, its ramps and footpath ramps | kg | 2013.00 |
| | | Reinforcement bars in R.C.C. for Seating Bollards | kg | 139.37 |
| SM-23 | 10.1 | Providing and fixing precast cement concrete M-20 grade (Using mechanical Concrete Mixer) kerb stone top and bottom width 115 and 165 mm respectively, 250 mm high on 150 mm thick PCC M-10 grade foundation as per design, including fixing at site as per clause 408 of MoRT&H Specification including all material, labour, machinery, lighting, guarding and maintenance of diversion. | | |
| | | Kerbstone for traffic island at Fatehpura Junction | metre | 28.40 |
| SM-24 | Non Scheduled | Procurement for Cycle Stands | Each | 4.00 |

RFP for Development of three Child and Family-friendly junctions and 1.5km Connected shared Street at Saheli Marg and Big Bazar Rd, Udaipur, Rajasthan

| Development of Family-friendly junctions and Connected shared Street at Saheli Marg, Udaipur, Rajasthan (Saheli Marg- ELECTRICAL- PART-B) | | | | |
|--|-----------------------|--|-------------|------------|
| S. No. | RUIDP SOR-2022 | ITEM DESCRIPTION | UNIT | QTY |
| SM-08 | E181300 | Providing & Fixing of IK07 IP 66 protected LED Street Light Luminaire on existing bracket/pole. Fixture made of powder coated single piece pressure die cast aluminum LM6/ ADC12 material with heat dissipation fins on housing with UV stabilized PC/Toughened Glass cover (UV stablization report submitted for UV cover) and secondary lens on each LED & should be SMD type . The System level Luminaire efficacy ≥ 120 lm/ wt with High Power LEDs is to be used and potted driver must be potted & has a unique BIS R number with Input Voltage AC 120 to 270 V AC with High voltage Cutoff @ ≥ 300 V AC and Auto resetting Safety ,Input Frequency 50Hz $\pm 3\%$ Power Factor > 0.95 driver Efficiency $> 85\%$,THD(I) 70 and CCT 5700K +355K. Surge protection shall be min ≥ 4 KV internal and min 10 KV external. driver should be Phase to phase protection of 440 V for 4 Hrs. Manufactures Word Mark/Name Engraved/Embossing on die cast housing to allow traceability/authenticity. Fixture shall be AS PER IS 10322 Complianced. OEM Must have its own in house NABL lab setup for all testing facilities for LED fixtures. (LM79/LM80) Certificate/ report with liable warranty of product/accessories from OEM shall be submitted. All as per pre approved by Engineer in charge. For additional technical parameters of products/ work , refer Annexure "A" attached with this BSR . | | |
| | E181304 | LED Street Light fixture 60 Watt | | |
| | | Street lights to be fixed on existing poles/ posts. | Each | 32.00 |

RFP for Development of three Child and Family-friendly junctions and 1.5km Connected shared Street at Saheli Marg and Big Bazar Rd, Udaipur, Rajasthan

| Development of Family-friendly junctions and Connected shared Street at Saheli Marg, Udaipur, Rajasthan (Saheli Marg - HORTICULTURE- PART-C) | | | | |
|---|-----------------------|--|-------------|------------|
| S. No. | RUIDP SOR-2022 | ITEM DESCRIPTION | UNIT | QTY |
| SM-07 | 39.3 | Supplying and stacking good earth at site of work. | | |
| | | 1) Loading, unloading and carriage to be paid extra as per actual lead. | | |
| | | 2) Earth measured in stacks will be reduced by 20% for payment | | |
| | | Good Earth in Seating with Planter | cum | 18.17 |
| SM-19 | 39.41 | Supply and planting following in poly bags / earthen pots well branched, well established & free from disease of 300 mm min. height ground covers at site in 0.3 m dia holes, 0.3 m deep dug in the ground, mixing the soil with decayed farm yard/sludge manure, backfilling the hole watering etc as required. | | |
| | | 39.41.4 Ophiopogon Black (Lily Turf, Mondograss) | sqm | 20.18 |
| | | 39.41.5 Asparagus myerii (Fox Tail) | sqm | 20.18 |
| | | 39.41.9 Pennisetum setaceum (Fountain Grass) | sqm | 20.18 |

RFP for Development of three Child and Family-friendly junctions and 1.5km Connected shared Street at Saheli Marg and Big Bazar Rd, Udaipur, Rajasthan

| Development of Family-friendly junctions and Connected shared Street at Big Bazar Rd, Udaipur, Rajasthan (Big Bazaar Road - CIVIL- PART-A) | | | | |
|---|----------------|---|-------|---------|
| S. No. | RUIDP SOR-2022 | ITEM DESCRIPTION | UNIT | QTY |
| BB-01 | 24.1 | Brick work with FPS bricks of class designation 75 in foundation and plinth in: | | |
| | 24.1.1 | Cement mortar 1:4 (1 cement : 4 coarse sand) Full Brick work in footing of seating with planter | cum | 17.24 |
| BB-02 | 24.7 | Brick work 7 cm thick with FPS brick of class designation 75 in cement mortar 1:3 (1 cement : 3 coarse sand) in superstructure Half brick work in seating with planter | sqm | 183.16 |
| | 32.2 | Cement plastering including T&P, scaffolding, material and complete labour, including cost of water, curing, racking of joints etc. with 15 mm cement plaster on the rough side of single or half brick wall of mix : | | |
| BB-03 | 32.2.1 | 1:4 (1 cement : 4 fine/ coarse sand) Plaster on seating with planter | sqm | 183.159 |
| | 30.21 | Chequered precast cement concrete tiles 22 mm thick in footpath & courtyard jointed with neat cement slurry mixed with pigment to match the shade of tiles including rubbing and cleaning etc. complete on 20 mm thick bed of cement mortar 1:4 (1 cement: 4 coarse sand). | | |
| BB-04 | 30.21.3 | Dark shade using ordinary cement. Finish for proposed pavements along Big Bazar Road | sqm | 2907.09 |
| | 10.1 | Providing and fixing precast cement concrete M-20 grade (Using mechanical Concrete Mixer) kerb stone top and bottom width 115 and 165 mm respectively, 250 mm high on 150 mm thick PCC M-10 grade foundation as per design, including fixing at site as per clause 408 of MoRT&H Specification including all material, labour, machinery, lighting, guarding and maintenance of diversion. Kerb stone for new footpath along the road side opposite to big bazar from semi circular junction upto Sukhadia Circle Kerb stone for traffic island at Sukhadiya circle | metre | 1086.68 |
| BB-05 | | | metre | 24.6 |
| | 9.10 | Providing and fixing of precast concrete interlocking tiles of desired shape of M 30 grade manufactured from fully computerized automatic stationery hydraulic vibro pressed machine and fully computerized automatic batching plant of class A1/A2 as per BS 6717:2001. The CC interlocking paving blocks be laid on average 50mm. thick bed of coarse | | |
| BB-06 | | | | |

RFP for Development of three Child and Family-friendly junctions and 1.5km Connected shared Street at Saheli Marg and Big Bazar Rd, Udaipur, Rajasthan

| Development of Family-friendly junctions and Connected shared Street at Big Bazar Rd, Udaipur, Rajasthan (Big Bazaar Road - CIVIL- PART-A) | | | | |
|---|----------------|--|------|---------|
| S. No. | RUIDP SOR-2022 | ITEM DESCRIPTION | UNIT | QTY |
| | | sand and the joint is to be filled with fine sand. Laying procedure on compacted sub-base as defined. Complete job is to be executed as per the instruction of Engineer incharge. The rates to be inclusive of all lead & Lifts etc. complete as per specifications. Tensile splitting strength, abrasion and braking load etc. as per BS 6717:2001, Grey cement. | | |
| | 9.10.3 | 100mm thick | | |
| | | C.C. Paver Blocks at Junction-1 | sqm | 552.150 |
| | | C.C. Paver Blocks at Junction-2 | sqm | 269.550 |
| | | C.C. Paver Blocks at Junction-3 | sqm | 45.660 |
| | | C.C. Paver Blocks at Junction-4 | sqm | 20.730 |
| | | C.C. Paver Blocks at Junction-5 | sqm | 40.080 |
| BB-07 | 10.8 | Providing and laying marking of center line and stop line etc with hot thermoplastic compound 2.5 mm thick on road/ plain surface, including reflectorising glass beads @ 250 gms per sqm area with special applicator machine, as per IRC:35 including cleaning the surface of all dirt, dust and other foreign matter, demarcation at site and traffic control involved. The finished surface to be level, uniform and free from streaks and holes as per clause 803 of MoRT&H Specification including all material, labour, machinery, lighting, guarding and maintenance of diversion. | sqm | 904.586 |
| BB-08 | 10.9 | Providing and fixing of retro- reflectorised cautionary, mandatory and informatory sign as per IRC :67 made of encapsulated lens type reflective sheeting vide clause 801.3, fixed over aluminium sheeting, 1.5 mm thick supported on a mild steel angle iron post 3 metre long and size 75 mm x 75 mm x 6 mm firmly fixed to the ground by means of properly designed foundation with M15 grade cement concrete 45 cm x 45 cm x 60 cm, 60 cm below ground level as per approved drawing including all material, labour. | | |
| | 10.9.2 | 60 cm equilateral triangle | each | 27 |
| | 10.9.3 | 60 cm circular | each | 3 |
| | | Both the above are traffic signage | | |
| BB-12 | 10.10 | Providing and erecting direction and place identification retroreflectorised sign as per IRC:67 made of encapsulated lens type reflective sheeting vide clause 801.3, fixed over aluminium sheeting, 2 mm thick framed to angle iron 40x40x5mm with area not exceeding | | |

RFP for Development of three Child and Family-friendly junctions and 1.5km Connected shared Street at Saheli Marg and Big Bazar Rd, Udaipur, Rajasthan

| Development of Family-friendly junctions and Connected shared Street at Big Bazar Rd, Udaipur, Rajasthan (Big Bazaar Road - CIVIL- PART-A) | | | | |
|---|----------------|---|------|---------|
| S. No. | RUIDP SOR-2022 | ITEM DESCRIPTION | UNIT | QTY |
| | | 0.9 sqm supported on a mild steel single angle iron post 75 x 75 x 6 mm firmly fixed to the ground by means of properly designed foundation with M15 grade cement concrete 45 x 45 x 60 cm, 60 cm below ground level as per approved drawing including all material, labour. | | |
| | | For rectangular wayfinding signage (size as per content) | sqm | 13 |
| BB-14 | 4.2 | Earth work in excavation for roadway, including trimming bottom and side slopes in accordance with requirement of line, grades and cross sections, including disposal of surplus material with all lift and lead upto 1000 metre as per MoRT&H specification clause 301. | | |
| | 4.2.1 | In all type of soil | | |
| | | Excavation for table tops | cum | 139.23 |
| | | Excavation for zebra crossing ramps | cum | 8.29 |
| | | Excavation for table top ramps | cum | 6.72 |
| BB-15 | 10.29 | Earth work in excavation of foundation of structures as per drawing and technical specification, including setting out, construction of shoring and bracing, removal of stumps and other deleterious matter, dressing of sides and bottom, backfilling the excavation earth to the extent required and utilising the remaining earth locally for road work in all kind of soil. | | |
| | | Excavation and backfilling for foundation of pergola posts | cum | 7.34 |
| BB-16 | 32.35 | Finishing walls with Acrylic Smooth exterior paint of required shade : | | |
| | 32.35.1 | New work (Two or more coat applied @ 1.67 ltr/10 sqm over and including base coat of water proofing cement paint applied @ 2.20 kg/ 10 sqm). | | |
| | | Floor Art | sqm | 1435.38 |
| | | Wall Art | sqm | 320.64 |
| | | Walls of seating with planter | sqm | 183.16 |
| BB-17 | 12.7 | Providing and fixing stone slab covering of required size over drains including filling of joints with cement sand mortar 1:3 complete as per direction of Engineer-in-charge. | | |
| | 12.7.2 | Average thickness 40 to 50 mm | | |
| | | For kota stone finish on seating with planter | sqm | 75.3 |
| BB-18 | DSR-2021-4.9 | Precasting and placing in position 125 mm dia Bollards 600 mm high of required shape including providing M.S. Pipe Sleeve 50 mm dia 300 mm long in the Bollard and M.S. Pipes 40 | | |

RFP for Development of three Child and Family-friendly junctions and 1.5km Connected shared Street at Saheli Marg and Big Bazar Rd, Udaipur, Rajasthan

| Development of Family-friendly junctions and Connected shared Street at Big Bazar Rd, Udaipur, Rajasthan (Big Bazaar Road - CIVIL- PART-A) | | | | |
|---|----------------|---|------|-------|
| S. No. | RUIDP SOR-2022 | ITEM DESCRIPTION | UNIT | QTY |
| | | mm dia and 450mm long with 150x150x6mm M.S. plate welded at bottom and embedded 150mm in cement concrete 1:3:6 (1 Cement : 3 coarse sand (zone-III) derived from natural sources : 6 graded stone aggregate 20 mm nominal size derived from natural sources), including necessary excavation of size 250x250x450mm deep for the same in bitumen/concrete pavement at specified spacing. | | |
| | | Precast bollards, including all items and cement in the foundation, but excluding cement in the section above ground | each | 407 |
| BB-19 | 21.1 | Providing and laying in position cement concrete of specified grade excluding the cost of centring and shuttering - All work upto plinth level : | | |
| | 21.1.2 | 1:1½:3 (1 Cement : 1½ coarse sand : 3 graded stone aggregate 20 mm nominal size). Cement in the section above ground of precast concrete bollards | cum | 2.76 |
| BB-20 | 21.1 | Providing and laying in position cement concrete of specified grade excluding the cost of centring and shuttering - All work upto plinth level : | | |
| | 21.1.5 | 1:3:6 (1 Cement : 3 coarse sand : 6 graded stone aggregate 20 mm nominal size). P.C.C. under brickwork for seating with planters | cum | 2.29 |
| BB-21 | 23.3 | Reinforced cement concrete work in beams, suspended floors, roofs having slope upto 15° landings, balconies, shelves, chajjas, lintels, bands, plain window sills, staircases and spiral stair cases upto two stories excluding the cost of centring, shuttering, finishing and reinforcement: | | |
| | 23.3.1 | M-15 Grade Concrete (1:2:4 (1 cement : 2 coarse sand : 4 graded stone aggregate 20 mm nominal size) -As per design mix) R.C.C. under table top and zebra crossing ramps | cum | 30.03 |
| | | R.C.C. in footing of the pergolas (450 x 450 x 750mm) | cum | 3.65 |
| BB-23 | 28.113 | Providing and fixing Bamboo jaffery/ fencing consisting of superior quality 25mm dia (Average) half cut bamboo placed vertically and fixed together with three numbers horizontal running members of hollock wood in scantling of section 50X25mm fixed with nails and G.I wire to existing surface complete as per direction of Engineer-in-charge. | | |
| | | Bamboo Jafri for screening of transformers on the road (Refer dwg. UD-CFCII-22-DET-08) | sqm | 28.8 |
| BB- | 28.57 | Providing beams including hoisting, fixing in position and applying wood preservative for the | | |

RFP for Development of three Child and Family-friendly junctions and 1.5km Connected shared Street at Saheli Marg and Big Bazar Rd, Udaipur, Rajasthan

| Development of Family-friendly junctions and Connected shared Street at Big Bazar Rd, Udaipur, Rajasthan (Big Bazaar Road - CIVIL- PART-A) | | | | |
|---|----------------|--|------|---------|
| S. No. | RUIDP SOR-2022 | ITEM DESCRIPTION | UNIT | QTY |
| 24 | | unexposed surfaces, etc. complete with : | | |
| | 28.57.2 | Hollock wood. Wood in Pergola- 150mm x 100mm rafter | cum | 22.68 |
| BB-25 | 29.2 | Structural steel work riveted, bolted or welded in built up sections, trusses and framed work, including cutting, hoisting, fixing in position and applying a priming coat of approved steel primer all complete: | | |
| | | Structural steel in Pergola- 300mm x 300mm hollow post with 10mm thickness | kg | 5428.8 |
| | | Structural steem peripheral and intermediate beams in Pergola- 150mm x 150mm hollow post of 5mm thickness | kg | 20376.1 |
| | | For baseplate in the pergolas | kg | 168.48 |
| | | For bolts,screws etc. for the pergolas (refer dwg. UD-CFCII-22-DET-05) | kg | 53.9136 |
| BB-26 | 32.47 | Providing and applying two coats of fire retardant paint unthinned on cleaned wood/ply surface @ 3.5 sqm per litre per coat including preparation of base surface as per recommendations of manufacturer to make the surface fire retardant. | | |
| | | Fire retardant paint on woodwork in Pergola- 300mm x 100mm rafter | sqm | 0.0029 |
| | | Fire retardant paint on woodwork in Pergola- 150mm x 100mm rafter | sqm | 226.8 |
| | | Fire retarudant paint on woodwork in Transformer screen in Bamboo Jafri | sqm | 28.8 |
| BB-28 | 23.19 | Reinforcement for R.C.C. work at all levels including straightening, cutting, bending, placing in position and binding all complete. | | |
| | | 23.19.6 Thermo-Mechanically Treated bars. | | |
| | | Reinforcement bars in R.C.C. for table tops and footpath ramps | kg | 1286 |
| | | Reinforcement bars in R.C.C. pergola foundation | kg | 555 |
| BB-30 | Non Scheduled | Procurement for Cycle Stands | Each | 2 |

RFP for Development of three Child and Family-friendly junctions and 1.5km Connected shared Street at Saheli Marg and Big Bazar Rd, Udaipur, Rajasthan

| Development of Family-friendly junctions and Connected shared Street at Big Bazar Rd, Udaipur, Rajasthan (Big Bazaar Road - ELECTRICAL- PART-B) | | | | |
|--|-----------------------|--|-------------|------------|
| S. No. | RUIDP SOR-2022 | ITEM DESCRIPTION | UNIT | QTY |
| BB-11 | E181300 | Providing & Fixing of IK07 IP 66 protected LED Street Light Luminaire on existing bracket/pole. Fixture made of powder coated single piece pressure die cast aluminum LM6/ ADC12 material with heat dissipation fins on housing with UV stabilized PC/Toughened Glass cover (UV stablization report submitted for UV cover) and secondary lens on each LED & should be SMD type . The System level Luminaire efficacy ≥ 120 lm/ wt with High Power LEDs is to be used and potted driver must be potted & has a unique BIS R number with Input Voltage AC 120 to 270 V AC with High voltage Cutoff ≥ 300 V AC and Auto resetting Safety ,Input Frequency $50\text{Hz} \pm 3\%$ Power Factor > 0.95 driver Efficiency $> 85\%$,THD(I) 70 and CCT 5700K +355K. Surge protection shall be min ≥ 4 KV internal and min 10 KV external. driver should be Phase to phase protection of 440 V for 4 Hrs. Manufactures Word Mark/Name Engraved/Embossing on die cast housing to allow traceability/authenticity. Fixture shall be AS PER IS 10322 Complianced. OEM Must have its own in house NABL lab setup for all testing facilities for LED fixtures. (LM79/LM80) Certificate/ report with liable warranty of product/accessories from OEM shall be submitted. All as per pre approved by Engineer in charge. For additional technical parameters of products/ work , refer Annexure "A" attached with this BSR . | | |
| | E181304 | LED Street Light fixture 60 Watt | | |
| | | Fixing street lights on existing poles/ posts | Each | 6.00 |

RFP for Development of three Child and Family-friendly junctions and 1.5km Connected shared Street at Saheli Marg and Big Bazar Rd, Udaipur, Rajasthan

| Development of Family-friendly junctions and Connected shared Street at Big Bazar Rd, Udaipur, Rajasthan (Big Bazaar Road - HORTICULTURE- PART-C) | | | | |
|--|----------------|--|------|--------|
| S. No. | RUIDP SOR-2022 | ITEM DESCRIPTION | UNIT | QTY |
| BB-09 | 39.3 | Supplying and stacking good earth at site of work. | | |
| | | 1) Loading, unloading and carriage to be paid extra as per actual lead. | | |
| | | 2) Earth measured in stacks will be reduced by 20% for payment | | |
| | | Good earth in planters with seating | cum | 16.467 |
| | | Good earth in traffic island | cum | 1.125 |
| BB-10 | 39.2 | Preparation of mounds of various size and shape by available excavated/surplus/earth in layers not exceeding 20 cm in depth, breaking clods, watering of each layer, dressing etc.lead upto 50 meters and lift upto 1.5 m as per direction of officers in charge. | | |
| | | Mound of approximate height 0.7m at proposed ITC seating and recreation area at Sukharia Circle Junction (refer dwg. A3-1-26) | cum | 12 |
| BB-13 | 4.1 | Dressing of earth work in surface excavation including cutting and filling upto 30cm depth including disposal of excavated earth upto 50m and lift upto 1.5 m. | | |
| | | Dressing of the proposed mound near Sukhadiya Circle junction | sqm | 54.89 |
| BB-22 | 39.41 | Supply and planting following in poly bags / earthen pots well branched, well established & free from disease of 300 mm min. height ground covers at site in 0.3 m dia holes, 0.3 m deep dug in the ground, mixing the soil with decayed farm yard/sludge manure, backfilling the hole watering etc as required. | | |
| | 39.41.4 | Ophiopogon Black (Lily Turf, Mondograss) | sqm. | 18.30 |
| | 39.41.5 | Asparagus myerii (Fox Tail) | sqm. | 18.30 |
| | 39.41.9 | Pennisetum setaceum (Fountain Grass) | sqm. | 18.30 |
| BB-27 | 39.43 | Supply and planting following in poly bags / earthen pots well branched, well established & free from disease of 600 mm min. height shrubs at site in 0.45 m dia holes, 0.45 m deep dug in the ground, mixing the soil with decayed farm yard/sludge manure, backfilling the hole watering etc as required. | | |
| | 39.43.1 | Rhaphis excelsa with 3-4 suckers (Lady Palm) | each | 5 |
| | 39.43.2 | Furcaria with 10-12 leaves (cactus) | each | 5 |
| | 39.43.3 | Agave with 10-12 leaves (Kamal Cactus) | each | 5 |
| | 39.43.4 | Phoenix sylvertris (Date Palm) | each | 5 |
| BB- | 39.13 | Grassing with 'Carpet' grass (selection no. 1) including watering and maintenance of the | | |

RFP for Development of three Child and Family-friendly junctions and 1.5km Connected shared Street at Saheli Marg and Big Bazar Rd, Udaipur, Rajasthan

| Development of Family-friendly junctions and Connected shared Street at Big Bazar Rd, Udaipur, Rajasthan (Big Bazaar Road - HORTICULTURE- PART-C) | | | | |
|--|----------------|--|------|-----|
| S. No. | RUIDP SOR-2022 | ITEM DESCRIPTION | UNIT | QTY |
| 29 | 39.13.2 | lawn for 30 days or more till the grass forms a thick lawn free from weeds and fit for moving including supplying good earth if needed.(The good earth shall be paid separately) | | |
| | | With grass Turf | | |
| | | Grass on earth mound at Sukhadia Circle | sqm | 15 |

RFP for Development of three Child and Family-friendly junctions and 1.5km Connected shared Street at Saheli Marg and Big Bazar Rd, Udaipur, Rajasthan

SECTION-12: - CONTRACT FORMS

Appendix 1: Details of Bidder

Appendix 2: Bid Submission Form

Appendix 3: Financial Bid/Price Schedule

Appendix 4: Power of Attorney for signing bid

Appendix 5: Bid Security (Bank Guarantee)

Appendix 6: Format for Evidence of Access to or Availability of Credit facilities

Appendix 7: Declaration for Blacklisting/Debarring

Appendix 8: Statement of Ethical Conduct, Fraud and Corruption

Appendix 9: Financial standing of the bidder

Appendix 10: Constructions works completed during last five years

Appendix 11: Experience in works of similar nature and size during last three years

Appendix 12: Existing Commitments and ongoing work

Appendix13: Indemnity Bond by the contractor for removal/disposal of surplus material/disposal

Appendix 14: Declaration for accepting Terms and Conditions of the Bid Document.

Appendix 15: Affidavit regarding correctness of Bidder 'Information/Documents/Certificates

Appendix 16: Performance Bank Guarantee

Appendix 17: Letter of Award

Appendix 18: Agreement form

Appendix 19: Notice to Proceed with the Work

Appendix 20: Completion Certificate

RFP for Development of three Child and Family-friendly junctions and 1.5km Connected shared Street at Saheli Marg and Big Bazar Rd, Udaipur, Rajasthan

1.1 Appendix 1: Details of Bidder

General

Name of Company:

Company Incorporation Details as per Company's Act 2013:

Address of the corporate headquarters and its branch office(s), if any, in India: Date of incorporation and/or commencement of business:

Brief description of the company including details of its main lines of business and proposed role and responsibility in this project.

Details of individual (s) who will serve as the point of contact/communication for the Company: Name:

Designation Company:

Address:

Telephone Number:

E-Mail Address:

Fax Number:

Particulars of the Authorised Signatory of the Bidder: Name:

Designation:

Address:

Phone Number: Fax Number:

RFP for Development of three Child and Family-friendly junctions and 1.5km Connected shared Street at Saheli Marg and Big Bazar Rd, Udaipur, Rajasthan

1.2 Appendix: 2 Bid Submission Form

Ref No.

Date:

To,
Commissioner,
Udaipur Municipal Corporation, Town Hall,
Udaipur, Rajasthan (313001)

Subject: Bid for: - Development of three Child and Family-friendly junctions and 1.5km Connected shared Street at Saheli Marg and Big Bazar Rd, Udaipur, Rajasthan.

Ref: Your Bid Document No. We, the undersigned, declare that:

We have examined and have no reservations to the Bidding Document, including Addenda No. _____

We offer to execute in conformity with the Bidding Document the following Works: - **Development of three Child and Family-friendly junctions and 1.5km Connected shared Street at Saheli Marg and Big Bazar Rd, Udaipur, Rajasthan.**

I/We offer to execute the works described above and remedy any defects therein during the DEFECT LIABILITY PERIOD of 01 year in conformity with the Conditions of Contract, Scope of Work, Technical Specifications, drawings, Bill of Quantities and Addenda for the sum (s) as quoted by me/ us in our Financial Bid.

- a) Our Bid shall be valid for a period of 180 days from the date of opening of technical bid in accordance with the Bidding Document, and it shall remain binding upon us and may be accepted at any time before the expiration of that period;
- b) If our Bid is accepted, we commit to submit a Performance Security in the amount of 10% (ten percent) of the Contract Price for the due performance of the Contract;
- c) We, including the subcontractor or suppliers for any part of the Contract, are/ shall be from India;
- d) We are not participating, as Bidder, in more than one Bid in this bidding process, other than alternative offers, if permitted, in the Bidding Document;
- e) Our firm/ company/ partner/ director and our sub-contractor has not been blacklisted/ debarred by State Government/ Central Government / PSU/ UMC/ Government authority in India;
- f) We understand that this Bid, together with your written acceptance thereof included in your notification of award, shall constitute a binding contract between us, until a formal Contract is prepared and executed;
- g) We understand that you are not bound to accept the lowest evaluated bid or any other bid that you may receive;
- h) We have not paid, or will pay any commissions or gratuities with respect to the bidding process and for execution of the Contract, if awarded;
- i) We declare that we have complied with and shall continue to comply with the provisions _____ of the Code of Integrity including Conflict of Interest as specified for Bidders in this Bidding

RFP for Development of three Child and Family-friendly junctions and 1.5km Connected shared Street at Saheli Marg and Big Bazar Rd, Udaipur, Rajasthan

Document during this procurement process and execution of the Works as per the Contract;

- j) Unless and until a formal agreement is prepared and executed this Bid together with your written acceptance thereof, shall constitute a binding contract between us.

Name/ address of the Authorized Representative of the Bidder:

Designation:

Signed

Duly authorized to sign the Bid for and on behalf of:

Stamp of the Bidder Date:

Tel:

Fax:

E-mail:

RFP for Development of three Child and Family-friendly junctions and 1.5km Connected shared Street at Saheli Marg and Big Bazar Rd, Udaipur, Rajasthan

1.3 Appendix 3: Financial Bid/Price Schedule

Financial Bid Proposal Format

(To be filled ONLINE Only; this is only a TEMPLATE)

| NAME OF THE BIDDER | | | | |
|--|---|--------------|----------------------------|--------------------------|
| This BOQ Template must not be modified/replaced by the bidder and the same should be uploaded after filling the relevant columns, else the bidder is liable to be rejected for this tender. Bidder is allowed to fill the Bidder Name and Values only. | | | | |
| S.No. | Job Description | Qty | Amount (In Figures) IN INR | Amount (In Words) IN INR |
| 1 | Part A – Saheli Marg | Complete Job | | |
| 2 | Part B – Big Bazaar Road | Complete Job | | |
| | TOTAL AMOUNT (PART A+ PART B) | | | |
| | | | | |
| 3 | PART C (OPERATION & MAINTENANCE) Operation & maintenance of the “Three Child and Family-friendly junctions and 1.5km Connected shared Street at Saheli Marg and Big Bazar Rd, Udaipur, Rajasthan” for the 5 years including one year defect liability period with the running cost of the electricity/diesel, T&P and manpower etc. | | | |
| 3.1 | Ist Year (Defect Liability Period) (Operation & Comprehensive Maintenance) | 12 months | | |
| 3.2 | IInd Year (Operation & Comprehensive Maintenance) | 12 months | | |
| 3.3 | IIIrd Year (Operation & Comprehensive Maintenance) | 12 months | | |
| 3.4 | IV Year (Operation & Comprehensive Maintenance) | 12 months | | |
| 3.5 | V Year (Operation & Comprehensive Maintenance) | 12 months | | |
| | TOTAL AMOUNT C | | | |
| | TOTAL (A+B+C) | | | |

RFP for Development of three Child and Family-friendly junctions and 1.5km Connected shared Street at Saheli Marg and Big Bazar Rd, Udaipur, Rajasthan

NOTE: 1. The above is inclusive of all duties, Taxes, levies, GST etc. as per prevailing rates.

CAPEX cost = 90% of the contract cost. O&M cost for 5 years = 10% of the contract cost

1. The payment of the O&M shall be limited to 10% of the contract cost and shall be paid in 12 equal installments over a period of five years.

Total Amount = Rs

Total Amount = (words)

Note:

- 1) If there is a discrepancy between the figures and words, the price quoted in words shall prevail.
- 2) This format is to be filled online only. Any hard copy submission of the Financial Bid shall lead to rejection of the Bid.
- 3) Bidder has to quote the price inclusive of all taxes
- 4) GST shall not be paid extra.

Signature of Authorized Representative

Name & Designation:

Name of Bidder:

Business Address Date:

Seal of the Bidder

RFP for Development of three Child and Family-friendly junctions and 1.5km Connected shared Street at Saheli Marg and Big Bazar Rd, Udaipur, Rajasthan

1.4 Appendix 4: - Power of Attorney for signing of Bid

Power of Attorney

(To be executed on non-judicial paper of appropriate value as per Stamp Act relevant to place of execution)

Know all men by these presents, We, _____ (name of the firm and address of the registered office) do hereby irrevocably constitute, nominate, appoint and authorize Mr/ Ms (name), _____ son/daughter/wife of _____ and presently residing at _____, who is presently employed with us and holding the position of _____ as our true and lawful attorney (hereinafter referred to as the "Attorney") to do in our name and on our behalf, all such acts, deeds and things as are necessary or required in connection with or incidental to submission of our Bid for the- "Contract for **Development of three Child and Family-friendly junctions and 1.5km Connected shared Street at Saheli Marg and Big Bazar Rd, Udaipur, Rajasthan**" on EPC basis proposed or being developed by the UMC (the "Employer") pursuant to the NIT document no. _____ issued by Employer, including but not limited to signing and submission of all applications, Bids and other documents and writings, participate in Bidders and other conference and providing information/ responses to the Employer, representing us in all matters before the Employer, signing and execution of all contracts including the Contract Agreement and undertakings consequent to acceptance of our Bid, and generally dealing with the Employer in all matters in connection with or relating to or arising out of our Bid for the said Project and/or upon award thereof to us and/or till entering into the Contract Agreement with the Employer.

AND we hereby agree to ratify and confirm and do hereby ratify and confirm all acts, deeds and things done or caused to be done by our said Attorney pursuant to and in exercise of the powers conferred by this Power of Attorney and that all acts, deeds and things done by our said Attorney in exercise of the powers hereby conferred shall and shall always be deemed to have been done by us.

IN WITNESS WHEREOF WE, _____ THE ABOVE-NAMED PRINCIPAL HAVE EXECUTED THIS POWER OF ATTORNEY ON THIS DAY OF 2023.

For

(Signature, name, designation and address of person authorized by Board Resolution (in case of Firm/ Company)/ partner in case of Partnership firm

Witnesses:

Accepted Notarized

Signature Name, designation and address of Attorney)

RFP for Development of three Child and Family-friendly junctions and 1.5km Connected shared Street at Saheli Marg and Big Bazar Rd, Udaipur, Rajasthan

1.5 Appendix 5: Bid Security (Bank Guarantee)

Bank's Name and Address of Issuing Branch or Office

Beneficiary: _____ name and address of Employer _____

Date: _____ Bid Security No.: _____

We have been informed that _____ name of the Bidder (here in after called "the Bidder") has submitted to you its bid dated (hereinafter called "the Bid") for the execution of _____ name of Contract under Invitation for Bids No. _____ ("the IFB").

Furthermore, we understand that, according to one of your conditions, bids must be supported by a bid guarantee. At the request of the Bidder, we _____ name of Bank hereby irrevocably undertake to pay you any sum or sums not exceeding in total an amount of _____ amount in figures _____ amount in words) upon receipt by us of your first demand in writing accompanied by a written statement stating that the Bidder is in breach of its

obligation(s) under the bid conditions, because the Bidders

- a) Has withdrawn its Bid during the period of bid validity including extended period of validity specified by the Bidder in the Form of Bid;
- b) Having been notified of the acceptance of its Bid by the Employer during the period of bid validity, (i) fails or refuses to execute the Contract Agreement, (ii) fails or refuses to furnish the performance security, in accordance with the ITB, or (iii) fails to deposit the required license fees with State Government to register itself as a special/ super class Contractor with Govt. of Rajasthan within 15 (fifteen) days of issue of letter of acceptance of Bid.

This guarantee will expire:

(a) if the Bidder is the successful Bidder, upon our receipt of copies of the Contract Agreement signed by the Bidder and the performance security issued to you upon the instruction of the Bidder; and

(b) if the Bidder is not the successful Bidder, upon the earlier of (i) our receipt of a copy your notification to the Bidder of the name of the successful Bidder; or (ii) twenty- eight days beyond the validity of the bid including extended period of validity.

Consequently, any demand for payment under this guarantee must be received by us at the office on or before that date.

Bank's seal and authorized signature(s).

RFP for Development of three Child and Family-friendly junctions and 1.5km Connected shared Street at Saheli Marg and Big Bazar Rd, Udaipur, Rajasthan

1.6 Appendix 6: - Format for Evidence of Access to or Availability of Credit Facilities

BANK CERTIFICATE

This is to certify that M/s_____is a reputed company with a good financial standing. If the contract for the work, namely "[insert name of the work]" is awarded to the above firm, we shall be able to provide overdraft/credit facilities to the extent of INR-_____ to meet their working capital requirements for executing the above contract.

Name of Bank

Senior Bank Manager

Address of the Bank

RFP for Development of three Child and Family-friendly junctions and 1.5km Connected shared Street at Saheli Marg and Big Bazar Rd, Udaipur, Rajasthan

1.7 Appendix 7: - Declaration regarding Blacklisting/Debarring

Bid Document No.

Date:

To,
Commissioner,
Udaipur Municipal Corporation, Town Hall,
Udaipur, Rajasthan (313001)

Subject: Bid for: - Development of three Child and Family-friendly junctions and 1.5km Connected shared Street at Saheli Marg and Big Bazar Rd, Udaipur, Rajasthan.

Sir/ Madam,

I/ We have carefully gone through the Terms & Conditions mentioned in the referred Bid Document. I/ We hereby declare that my company / firm/ partner/ director/ owner is not currently debarred/ blacklisted by any State Government / Central Government / PSU / Government Authority in India/ UMC as on the Bid Submission Date.

or I declare the following: -

| S. No. | Blacklisted / debarred by State Government / Central Government / PSU | Reason | Date on which blacklisting/ debarment notification was issued |
|--------|---|--------|---|
| | | | |

NOTE: In case the company/ firm/ partner/ director/ owner was blacklisted previously, please provide the details regarding the Period for which the company/ firm/ partner/ director/ owner was blacklisted/ debarred and the reason/s for the same)

Yours faithfully

(Signature of the Bidder) Name:

Designation: Seal:

Date:

Business Address:

RFP for Development of three Child and Family-friendly junctions and 1.5km Connected shared Street at Saheli Marg and Big Bazar Rd, Udaipur, Rajasthan

1.8 Appendix 8: Statement of Ethical Conduct, Fraud and Corruption

We, the undersigned confirm in the preparation of our bid that:

- 1) Neither we, nor any of our employees, associates, agents, shareholders, consultants, partners or their relatives or associates have any relationship that could be regarded as a conflict of interest as set out in the bidding document.
- 2) Should we become aware of the potential for such a conflict will report it immediately to the procuring organization.
- 3) That neither we, nor any of our employees, associates, agents, shareholders, partners consultants or their relatives or associates have entered into corrupt, fraudulent, coercive or collusive practices in respect of our bid or proposal.
- 4) We understand our obligation to allow the Government of Udaipur & Kashmir to inspect all records relating to the preparation of our bid and any contract that may result from such, irrespective of if we are awarded a contract or not.
- 5) In connection with this procurement exercise and any contract that is awarded to us as a result thereof, no payments have been made or will be made by us, our associates, agents, shareholders, partners or their relatives or associates to any of the staffs, associates, consultants, employees or relatives of such who are involved with the procurement process, contract implementation, and the issuance of progress payment on behalf of the purchaser, client or employer.

Signed: *[signature of person authorized by the Bidder to sign the bid submission form and whose name and title are shown below]*

Name: [insert full name] Title: [insert official title]

Duly authorized to sign the bid for and on behalf of: [insert complete name of Bidder] Dated on day of [insert date of signing}.

RFP for Development of three Child and Family-friendly junctions and 1.5km Connected shared Street at Saheli Marg and Big Bazar Rd, Udaipur, Rajasthan

1.9 Appendix 9: - Financial standing of the Bidder

| S/n | Year | Turnover (INR₹ in Lakhs.) |
|-----|----------|---------------------------|
| 1. | 2018-19 | |
| 2. | 2019-20 | |
| 3. | 20120-21 | |
| 4. | 2021-22 | |
| 5. | 2022-23 | |

RFP for Development of three Child and Family-friendly junctions and 1.5km Connected shared Street at Saheli Marg and Big Bazar Rd, Udaipur, Rajasthan

1.10 Appendix 10: - Constructions Works completed during last Five years

| S/n | Financial Year | Value of Works completed (in INR₹ lakhs) |
|-----|----------------|--|
| 1. | 2018-19 | |
| 2. | 2019-20 | |
| 3. | 20120-21 | |
| 4. | 2021-22 | |
| 5. | 2022-23 | |

RFP for Development of three Child and Family-friendly junctions and 1.5km Connected shared Street at Saheli Marg and Big Bazar Rd, Udaipur, Rajasthan

1.11 Appendix 11: - Experience in works of similar nature and size during last five years

| Year | Project Name | Details of the Employer | Description of Work | Contract No. | Value of the Contract (INR Lakhs) | Date of Commencement | Stipulated Period of Completion | Actual Date of Completion | Remarks Explaining Reasons for Delays |
|---------|--------------|-------------------------|---------------------|--------------|-----------------------------------|----------------------|---------------------------------|---------------------------|---------------------------------------|
| 2018-19 | | | | | | | | | |
| 2019-20 | | | | | | | | | |
| 2020-21 | | | | | | | | | |
| 2021-22 | | | | | | | | | |
| 2022-23 | | | | | | | | | |

Note: Attach certificate (s) from the Engineer(s)- in- Charge, not below the rank of Executive Engineer regarding all completed & ongoing works

RFP for Development of three Child and Family-friendly junctions and 1.5km Connected shared Street at Saheli Marg and Big Bazar Rd, Udaipur, Rajasthan

1.12 Appendix 12: - Existing commitments and on-going works:

| Years | Description of works | Place & State | Name & Address of Employer. | Value of Contract (INR. Cr) | Stipulated Period of Completion | Value of works to be completed (INR- Cr) | Anticipated date of completion |
|----------|----------------------|---------------|-----------------------------|-----------------------------|---------------------------------|--|--------------------------------|
| | 1 | 2 | 4 | 5 | 6 | 7 | 8 |
| 2018-19 | | | | | | | |
| 2019-20 | | | | | | | |
| 20120-21 | | | | | | | |
| 2021-22 | | | | | | | |
| 2022-23 | | | | | | | |

RFP for Development of three Child and Family-friendly junctions and 1.5km Connected shared Street at Saheli Marg and Big Bazar Rd, Udaipur, Rajasthan

1.13 Appendix 13: - Indemnity Bond to be executed by the Contractor for the Removal/Disposal of Scrap/Disposal or Surplus material

(TO BE EXECUTED ON STAMP PAPER OF APPROPRIATE VALUE) INDEMNITY BOND

This INDEMNITY BOND executed this day of 20

by (Name of Company), a Company registered under the Companies Act, 1956/ Partnership Firm/ Proprietary Concern and having its registered office(s) at (Office Address), hereinafter called the Indemnifier(s) / Contractor(s) (which expression shall, unless excluded by or repugnant to the context, be deemed to mean and include its successors, administrators, executors and permitted assignees).

IN FAVOUR OF UMC, having its registered office (hereinafter referred to as "UMC"). UMC has awarded the Contractor(s), contract for execution of work ("Scope of Work") as mentioned in the contract agreement/ LOI no dated, entered into between UMC and Contractor(s), relating to

(Name & Address of Project) (hereinafter called 'the Project'). The Indemnifier(s) for the purpose of execution of its Scope of Work had from time to time procured and stored

(Details of Material) at the Project Site.

After completion of the Scope of Work by Indemnifier(s), it has been identified that scrap (Details of Scrap Material & its Quantity) and/or surplus (Details of Surplus Material & its Quantity) belonging to Indemnifier(s) is lying at the said Project Site. Now, the scrap

(Details of Scrap Material & its Quantity) and / or surplus

(Details of Surplus Material & its Quantity) belonging to the Indemnifier(s), requires to be removed by Indemnifier(s) from the Project Site

NOW THEREFORE THIS INDEMNITY BOND WITNESSETH AS UNDER:

That Indemnifier(s) by way of this indemnity requests UMC to issue approval in favour of Indemnifier(s) for removal of scrap (Details of Scrap Material & its Quantity) and / or surplus (Details of Surplus Material & its Quantity) belonging to Indemnifier(s), from the project.

That the Indemnifier(s) shall ensure clearing of its scrap (Details of Scrap Material & its Quantity) and/ or surplus (Details of Surplus Material & its Quantity) by itself, as aforesaid.

That Indemnifier(s) in consideration of the premises above, for itself and its respective, executors, administrators and assigns, jointly and severally agree and undertake from time to time and at all times hereafter to indemnify UMC and keep UMC indemnified from and against all claims, demands, actions, liabilities and expenses which may be made or taken against or incurred by UMC by reason of the issue of necessary approval by UMC and permitting Indemnifier(s) to remove scrap (Details of Scrap Material & its Quantity) and / or

RFP for Development of three Child and Family-friendly junctions and 1.5km Connected shared Street at Saheli Marg and Big Bazar Rd, Udaipur, Rajasthan

surplus (Details of Surplus Material & its Quantity) belonging to Indemnifier(s), from the project.

That Indemnifier(s) undertakes to indemnify and keep UMC harmless from any act of omission or negligence on the part of the Contractor in following the statutory requirements with regard to removal/disposal of scrap and surplus belonging to Indemnifier(s), from the Project Site aforesaid, by the Indemnifier(s). Further, in case the laws require UMC to take prior permission of the relevant Authorities before handing over the scrap and/or surplus to the Indemnifier, the same shall be obtained by the Indemnifier on behalf of UMC.

IN WITNESS WHEREOF, the Indemnifier(s), through its authorized representative, has executed Month and Year first mentioned above at

(Name of the Place)

Witness:

Indemnifier

(Authorized Signatory)

RFP for Development of three Child and Family-friendly junctions and 1.5km Connected shared Street at Saheli Marg and Big Bazar Rd, Udaipur, Rajasthan

1.14 Appendix 14: - DECLARATION FOR ACCEPTING TERMS AND CONDITIONS OF BID DOCUMENT

Bid Document No.

Date:

To,
Commissioner,
Udaipur Municipal Corporation, Town Hall,
Udaipur, Rajasthan (313001)

Subject: Bid for: - Development of three Child and Family-friendly junctions and 1.5km Connected shared Street at Saheli Marg and Big Bazar Rd, Udaipur, Rajasthan

Sir/ Madam,

I have carefully gone through the Terms & Conditions mentioned in the above referred Bid Document. I declare that all the provisions of this Bid Document are acceptable to my company/ firm who has submitted its Bid as the Bidder for this Project. I further certify that I am an Authorized Representative of my company/ firm i.e., the Bidder and am therefore, competent to make this declaration. I further undertake on behalf of my company/ firm that we shall abide by the Bid including the Financial Bid submitted by my company/ firm.

Yours faithfully,

(Signature of the Bidder) Name:

Designation: Seal:

Date:

Business Address:

RFP for Development of three Child and Family-friendly junctions and 1.5km Connected shared Street at Saheli Marg and Big Bazar Rd, Udaipur, Rajasthan

1.15 APPENDIX-15: Affidavit regarding correctness of Bidder's Information/ Documents/ Certificates

I/we _____ who is/ are _____ (status in the firm/ company) and competent for submission of the affidavit on behalf of M/S _____ (contractor) do solemnly affirm an oath and state that:

I/we am/are fully satisfied for the correctness of the certificates/records submitted in support of the following information in bid documents which are being submitted in response to notice inviting e-tender No. _____ for _____ (name of work) dated _____ issued by the _____ (name of the department).

I/we are fully responsible for the correctness of following information/ documents and certificates:

1. That the self-certified information given in the bid document is fully true and authentic. 2. That:
 - a) Proof for cost of bid document and other relevant documents provided by the Bank are authentic.
 - b) Information regarding financial qualification and annual turn-over is correct.
 - c) Information regarding various technical qualifications is correct.

Signature with Seal of the Deponent (bidder)

I/ We, _____, above deponent, do hereby certify that the facts mentioned in above paras 1 to 2 are correct to the best of my knowledge and belief. Verified today _____ (dated) at _____ (place).

Signature with Seal of the Deponent (bidder)

Note: Affidavit duly notarized in original shall and to be submit along with the technical part of the bid

RFP for Development of three Child and Family-friendly junctions and 1.5km Connected shared Street at Saheli Marg and Big Bazar Rd, Udaipur, Rajasthan

1.16 Appendix 16: - PERFORMANCE BANK GUARANTEE

Bank's name, and address of issuing branch or office

Beneficiary: Name and address of the employer.....

Date:

Performance Guarantee No.:

We have been informed that _____ name of the contractor _____ (hereinafter called "the Contractor") has entered into Letter of Award No. _____ reference number of the contract _____ dated _____ with you, for the execution of name of contract and brief description of works (hereinafter called "the Contract").

Furthermore, we understand that, according to the conditions of the Contract, a performance guarantee is required. At the request of the Contractor, we name of the bank hereby irrevocably undertake to pay you any sum or sums not exceeding in total an amount of name of the currency and amount in words _____ (amount in figures _____) such sum being payable in the types and proportions of currencies in which the Contract Price is payable, upon receipt by us of your first demand in writing accompanied by a written statement stating that the Contractor is in breach of its obligation(s) under the Contract, without your needing to prove or to show grounds for your demand or the sum specified therein.

This guarantee shall expire, no later than the Day of , 3, and any demand for payment under it must be received by us at this office on or before that date.

Signature(s) and seal of bank (where appropriate)

RFP for Development of three Child and Family-friendly junctions and 1.5km Connected shared Street at Saheli Marg and Big Bazar Rd, Udaipur, Rajasthan

1.17 Appendix 17: - LETTER OF AWARD

NOTIFICATION OF AWARD / LETTER OF ACCEPTANCE

To,
Commissioner,
Udaipur Municipal Corporation, Town Hall,
Udaipur, Rajasthan (313001)

Subject: Bid for: - Development of three Child and Family-friendly junctions and 1.5km Connected shared Street at Saheli Marg and Big Bazar Rd, Udaipur, Rajasthan

Dear Sir,

It is to notify you that your Bid dated Contract for **Development of three Child and Family-friendly junctions and 1.5km Connected shared Street at Saheli Marg and Big Bazar Rd, Udaipur, Rajasthan** bearing Bid Ref. No. Commissioner/UMC/2020-21/ dated for the Accepted Contract Amount of Rs. only (Rupees only), as against Rs. (Rs. only) of the tendered cost in accordance with the NIT is hereby accepted by UMC and you are hereby declared as the Successful Bidder.

You, the Successful Bidder, is requested to return the duly signed and stamped duplicate copy of this Letter of Acceptance/ Notification of Award within 7 (seven) days from the date of receipt of this LoA, as a token of the receipt and acknowledgment of this LoA, and undertaking of absolute, unconditional and unqualified compliance of the conditions mentioned herein.

Further, you are requested to furnish the Performance Security at the rate of 10% of Bid price for an amount of Rs. (Rupees only) as per Sub Clause in favour of "Commissioner, UMC" within 07 (seven) days of the receipt of this Letter of Acceptance/ Notification of Award, in accordance with the Conditions of Contract, using for that purpose the Performance Security as per Appendix 16 of the RFP document failing which action as per clause 3.29.4(c) of ITB shall be initiated. Such Performance Security shall be valid up to 60 days beyond the expiry of the Defect Liability Period. The performance security shall be in the form of an unconditional irrevocable bank guarantee issued by a Scheduled Commercial Bank.

Once the Performance Security is furnished by you, the Successful Bidder, for the requisite amount and in the format as prescribed, UMC shall execute the Contract Agreement with you. Accordingly, it is requested that stamp paper of appropriate value (purchased from the UT of Udaipur and Kashmir) be provided to the UMC for further necessary action.

Yours Sincerely,

Commissioner,
Udaipur Municipal Corporation

RFP for Development of three Child and Family-friendly junctions and 1.5km Connected shared Street at Saheli Marg and Big Bazar Rd, Udaipur, Rajasthan

1.18 Appendix 18 - Agreement Form

THIS AGREEMENT made the _____ day of _____ between name of the employer (hereinafter "the Employer"), of the one part, and name of the contractor hereinafter "the Contractor"), of the other part:

WHEREAS the Employer desires that the Works known as _____ name of the contractor should be executed by the Contractor, and has accepted a Bid by the Contractor for the execution and completion of these Works and the remedying of any defects therein,

The Employer and the Contractor agree as follows:

- 1) In this Agreement, words and expressions shall have the same meanings as are respectively assigned to them in the Contract documents referred to.
- 2) The following documents shall be deemed to form and be read and construed as part of this Agreement. This Agreement shall prevail over all other Contract documents.

The Contract Agreement,
The Letter of Award and Acceptance, Pre-bid replies
Minutes of Negotiation Meeting
The Letters of Technical Bid and Price Bid, The Particular Conditions of Contract, The General Conditions of Contract,
The Specifications, The Drawings,
The Completed Activity Schedules or Bill of Quantities Tender Document, and
any other documents shall be added here.

- 3) In consideration of the payments to be made by the Employer to the Contractor as indicated in this Agreement, the Contractor hereby covenants with the Employer to execute the Works and to remedy defects therein in conformity in all respects with the provisions of the Contract.
- 4) The Employer hereby covenants to pay the Contractor in consideration of the execution and completion of the Works and the remedying of defects therein, the Contract Price or such other sum as may become payable under the provisions of the Contract at the times and in the manner prescribed by the Contract.

IN WITNESS whereof the parties hereto have caused this Agreement to be executed in accordance with the laws of _____ name of the borrowing country _____ on the day, month and year indicated above.

RFP for Development of three Child and Family-friendly junctions and 1.5km Connected shared Street at Saheli Marg and Big Bazar Rd, Udaipur, Rajasthan

Signed by Signed by.....

for and on behalf of the Employer for and on behalf the Contractor

in the presence of: in the presence of:

Witness, Name, Signature, Address, Date Witness, Name, Signature, Address, Date

RFP for Development of three Child and Family-friendly junctions and 1.5km Connected shared Street at Saheli Marg and Big Bazar Rd, Udaipur, Rajasthan

1.19 Appendix 19: -Noticed to proceed with the work

[Letterhead of the Employer]

[date]

To
[Name and address of the contractor]

Dear Sir

Pursuant to your furnishing the performance security [and additional performance security] as stipulated in ITB Clause 3.34 and signing of the contract agreement on [date] for the work "[insert name of the work]" at the Contract Price of INR₹[], you are hereby instructed to proceed with the execution of the said works in accordance with the contract documents.

Your Faithfully s[signature] [name and title]

RFP for Development of Sensory Park at Gulab Bagh, Udaipur, Rajasthan

1.20 Appendix 20: - Completion Certificate

I, (Name of the UMC Engineer), acting as the Engineer, under and in accordance with the Agreement dated _____ (the "Agreement"), for Name of work on EPC basis through _____ (Name of Contractor), hereby certify that the Tests and Trial runs in accordance with the Agreement have been successfully undertaken to determine compliance of the Project _____ with the provisions of the Agreement, and I am satisfied that the Project can be safely and reliably placed in service of the Users thereof.

It is certified that, in terms of the aforesaid Agreement, all works forming part of Project have been completed, and the Project is hereby declared fit for into operation on this the day of 2023

.

SIGNED, SEALED AND DELIVERED

RFP for Development of Sensory Park at Gulab Bagh, Udaipur, Rajasthan

Appendix 21: - FORM OF JOINT VENTURE AGREEMENT (ON NON-JUDICIAL STAMP PAPER OF Rs 300/- TO BE PURCHASED IN THE NAME OF JOINT VENTURE)

JOINT VENTURE AGREEMENT
BETWEEN.....AND.....
.....for BID SPECIFICATION NO..... This Joint
Venture Agreement executed on this.....day of.....Two thousand..... and.....
between M/s. a company incorporated under the Companies Act,
1956.....and having its Registered Office at
(hereinafter called the "Lead Partner" which expression shall include its successors, executors
and permitted assigns) and M/s.a company
incorporated under the Companies Act, 1956.....and having its
Registered Office at (hereinafter called the "Partner" which
expression shall include its successors, executors and permitted assigns) for the purpose of
making a bid and entering into a contract (in case of award) against Tender Specification
No., incorporated under the Companies Act of 1956 having its
Registered Office at(hereinafter called the "Employer). WHEREAS the Employer
invited bids as per the above mentioned Specification for the similar nature of work
..... AND WHEREAS "Qualification Requirement of the Bidder", forming
part of the bidding documents, stipulates that a Joint Venture of two qualified firms as
partners, meeting the requirement of Qualification Requirement of the Bidder", as applicable
may bid, provided the Joint Venture fulfills all other requirements of relevant Section of RfP
and in such a case, the BID shall be signed by all the partners so as to legally bind all the
Partners of the Joint Venture, who will be jointly and severally liable to perform the Contract
and all obligations hereunder. The above clause further states that the Joint Venture
Agreement shall be attached with the bid and the contract performance guarantee will be
as per the format enclosed with the bidding document without any restriction or liability for
either party. AND WHEREAS the bid has been submitted to the Employer vide proposal
No..... dated.....by Lead Partner based on the Joint Venture agreement between its
Partners under these presents and the bid in accordance with the requirements of
(Evaluation &Qualification Criteria), has been signed by all the partners.

NOW THIS INDENTURE WITNESSETH AS UNDER:

In consideration of the above agreements, all the Partners to this Joint Venture do hereby
now agree as follows:

1. In consideration of the award of the Contract by the Employer to the Joint Venture
partners, we, the Partners to the Joint Venture agreement do hereby agree that
M/s.....shall act as Lead Partner and further declare and
confirm that we shall jointly and severally be bound unto the Employer for the successful
performance of the Contract and shall be fully responsible for the similar nature of work,
and successful performance of the equipment in accordance with the bid clauses.
2. In case of any breach of the said Contract by the Lead Partner or other Partner(s) of the
Joint Venture agreement, the other Partner do hereby agree to be fully responsible for the
successful performance of the Contract and to carry out all the obligations and

RFP for Development of Sensory Park at Gulab Bagh, Udaipur, Rajasthan

responsibilities under the Contract in accordance with the requirements of the bid document.

3. Further, if the Employer suffers any loss or damage on account of any breach in the Contract or any shortfall in the performance of the equipment in meeting the performance guaranteed as per the specification in terms of the Contract, the Partner(s) of these presents undertake to promptly make good such loss or damages caused to the Employer, on its demand without any demur. It shall not be necessary or obligatory for the Employer to proceed against Lead Partner to these presents before proceeding against or dealing with the other Partner(s).
4. The financial liability of the Partners of this Joint Venture agreement to the Employer, with respect to any of the claims arising out of the performance or non-performance of the obligations set forth in the said Joint Venture agreement, read in conjunction with the relevant conditions of the Contract shall, however, not be limited in any way so as to restrict or limit the liabilities of any of the Partners of the Joint Venture agreement.
5. It is expressly understood and agreed between the Partners to this Joint Venture agreement that the responsibilities and obligations of each of the Partners shall be as delineated in Appendix-I (*To be incorporated suitably by the Partners) to this agreement. It is further agreed by the Partners that the above sharing of responsibilities and obligations shall not in any way be a limitation of joint and several responsibilities of the Partners under this Contract.
6. This Joint Venture agreement shall be construed and interpreted in accordance with the laws of India and the courts of Udaipur, Rajasthan shall have the exclusive jurisdiction in all matters arising there under.
7. It is further agreed that the Joint Venture agreement shall be irrevocable and shall form an integral part of the Contract, and shall continue to be enforceable till the Employer discharges the same. It shall be effective from the date first mentioned above for all purposes and intents.

IN WITNESS WHEREOF, the Partners to the Joint Venture agreement have through their authorized representatives executed these presents and affixed Common Seals of their companies, on the day, month and year first mentioned above.

1. Common Seal of..... For Lead Partner has been affixed in my/our presence pursuant to the Board of Director's resolution (Signature of authorized representative) dated..... Name.....
Signature..... Designation.....
Name..... Common Seal of the company
Designation.....

2. Common Seal of..... For other Partners has been affixed in my/our presence pursuant to the Board of Director's resolution (Signature of authorized representative) dated..... Name..... Signature.....
Designation..... Name..... Common Seal of the company
Designation.....

RFP for Development of Sensory Park at Gulab Bagh, Udaipur, Rajasthan

WITNESSES:

1. (Signature).....

2 (Signature)..... Name Name.....
..... (Official address) (Official
address)

***** End of Document ***